



FT7521

Reset Timer with Fixed Delay and Reset Pulse

Features

- Fixed Reset Delay: 7.5 Seconds
- One Input Reset Pin
- Open-Drain Output Pin with Fixed 400ms Pulse
- 1.8 V to 5.0 V Operation ($T_A = -40^\circ\text{C}$ to $+85^\circ\text{C}$)
- 1.7 V to 5.0 V Operation ($T_A = -25^\circ\text{C}$ to $+85^\circ\text{C}$)
- 1.65 V to 5.00 V Operation ($T_A = 0^\circ\text{C}$ to $+85^\circ\text{C}$)
- $<1 \mu\text{A}$ I_{CCQ} Consumption
- Zero-Second Test-Mode Enable
- Integrated Pull-Up Resistor on /SRO

Applications

- Cell Phones
- Portable Media Players
- Tablets
- Mobile Devices
- Consumer Medical

Description

The FT7521 is a timer for resetting a mobile device where long reset times are needed. The long delay helps avoid unintended resets caused by accidental key presses. It has a fixed delay of $7.5 \pm 20\%$ seconds. The DSR pin enables Test Mode operation by immediately forcing /RST1 LOW for factory testing.

The FT7521 has one input for single-button resetting capability. The device has a single open-drain output with 0.5 mA pull-down drive.

FT7521 draws minimal I_{CC} current when inactive and functions over a power supply range of 1.65 V to 5.0 V.

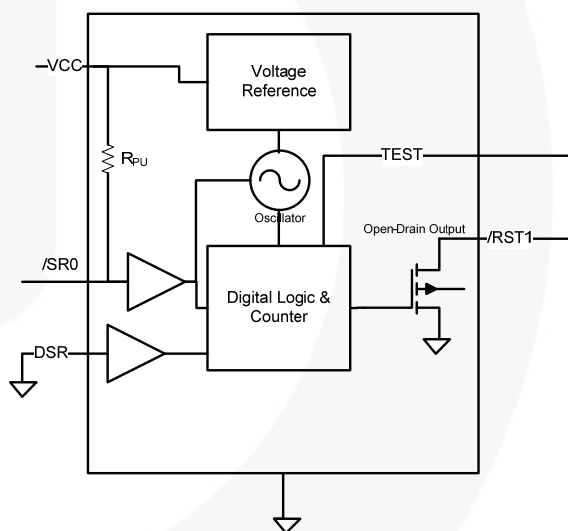

Figure 1. Block Diagram

Ordering Information

Part Number	Operating Temperature Range	Package	Packing Method
FT7521L6X	-40°C to +85°C	6-Lead, MicroPak™ 1.0 x 1.45 mm, JEDEC MO-252	5000 Units on Tape and Reel
FT7521FHX (Preliminary)		6-Lead, MicroPak2™ 1.0 x 1.0 mm Body, .35 mm Pitch	

Recommended Application Diagram

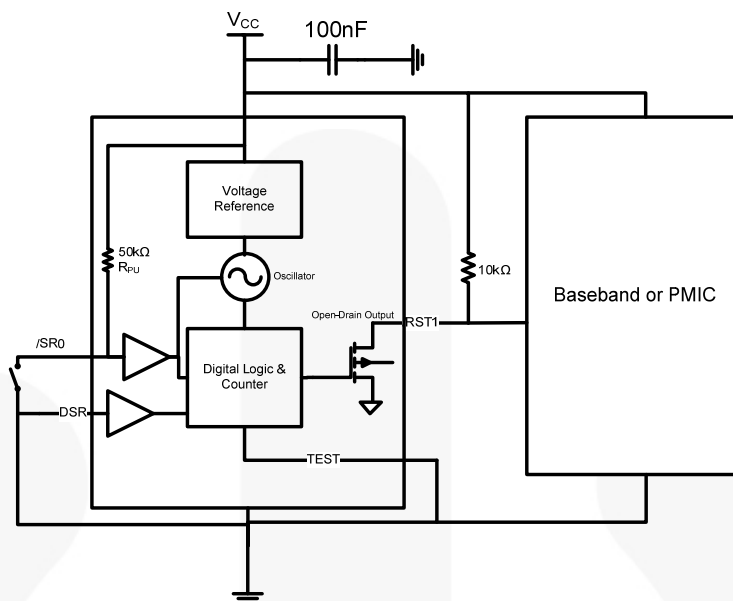

Figure 2. Recommended Application Diagram

Pin Configuration

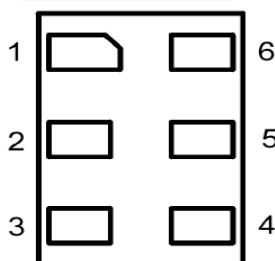

Figure 3. Pad Assignments (Top-Through View)

Pin Definitions

Pin #	Name	Description	
		Normal Operation	Zero-Second Factory-Test Mode
1	/RST1	Open-drain output, active LOW	Open-drain output, active LOW
2	GND	GND	GND
3	/SR0	Reset Input with Integrated pull-up, active LOW	Reset input with integrated pull-up, active LOW
4	VCC	Power supply	Power supply
5	DSR	Delay selection input; tie to GND during normal operation. ⁽¹⁾	Delay selection input. Pull HIGH to enable zero-second delay for factory test.
6	TEST	Used for device testing; tie to GND during normal operation.	Used for device testing; tie to GND during normal operation.

Note:

1. This pin must always be tied to either GND or VCC. It must not float.

Absolute Maximum Ratings

Stresses exceeding the absolute maximum ratings may damage the device. The device may not function or be operable above the recommended operating conditions and stressing the parts to these levels is not recommended. In addition, extended exposure to stresses above the recommended operating conditions may affect device reliability. The absolute maximum ratings are stress ratings only.

Symbol	Parameter	Condition	Min.	Max.	Unit
V _{CC}	Supply Voltage		-0.5	7.0	V
V _{IN}	DC Input Voltage	/SR0, DSR	-0.5	7.0	V
V _{OUT}	Output Voltage ⁽²⁾	/RST1	-0.5	7.0	V
I _{IK}	DC Input Diode Current	V _{IN} < 0V		-50	mA
I _{OK}	DC Output Diode Current	V _{OUT} < 0V		-50	mA
I _{OL}	DC Output Sink Current			+50	mA
I _{CC}	DC V _{CC} or Ground Current per Supply Pin			±100	mA
T _{STG}	Storage Temperature Range		-65	+150	°C
T _J	Junction Temperature Under Bias			+150	°C
T _L	Junction Lead Temperature, Soldering 10 Seconds			+260	°C
P _D	Power Dissipation			5	mW
ESD	Electrostatic Discharge Capability	Human Body Model, JESD22-A114		4	kV
		Charged Device Model, JESD22-C101		2	

Note:

- All output current Absolute Maximum Ratings must be observed.

Recommended Operating Conditions

The Recommended Operating Conditions table defines the conditions for actual device operation. Recommended operating conditions are specified to ensure optimal performance to the datasheet specifications. Fairchild does not recommend exceeding them or designing to Absolute Maximum Ratings.

Symbol	Parameter	Condition	Min.	Max.	Unit
V _{CC}	Supply Voltage ⁽³⁾	-40°C to +85°C	1.8	5.0	V
		-25°C to +85°C	1.7	5.0	
		0°C to +85°C	1.65	5.00	
t _{RFC}	V _{CC} Recovery Time After Power Down	V _{CC} =0 V After Power Down, Rising to 0.5 V	5		ms
V _{IN}	Input Voltage ⁽³⁾	/SR0	0	5	V
V _{OUT}	Output Voltage	/RST1	0	5	V
I _{OL}	DC Output Sink Current	/RST1, V _{CC} =1.8 V to 5.0 V		+3	mA
T _A	Free-Air Operating Temperature		-40	+85	°C
θ _{JA}	Thermal Resistance			350	°C/W

Note:

- V_{CC} supply should never be allowed to float while input pins are driven.

DC Electrical Characteristics

Conditions of $T_A = -40$ to 80°C with $V_{CC} = 1.8 - 5.0\text{ V}$ OR $T_A = -25$ to 85°C with $V_{CC} = 1.7 - 5\text{ V}$ OR $T_A = 0$ to 85°C with $V_{CC} = 1.65 - 5\text{ V}$ produce the performance characteristics below.

Symbol	Parameter	Condition	Min.	Typ.	Max.	Unit
V_{IH}	Input High Voltage	DSR, /SR0	$0.65 \times V_{CC}$			V
V_{IL}	Input Low Voltage	DSR, /SR0			$0.25 \times V_{CC}$	V
V_{OL}	Low Level Output Voltage	RST, $I_{OL} = 500\ \mu\text{A}$			0.3	V
		RST, $I_{OL} = 3\text{ mA}$, $V_{CC} = 3.0\text{ V}$		0.3		
R_{PU}	Integrated Pull-Up Resistor on /SR0			50		k Ω
I_{IN}	Input Leakage Current /SR0	$V_{IN} = V_{CC}$			± 1.0	μA
	Input Leakage Current DSR	$0\text{V} \leq V_{IN} \leq 5.0\text{ V}$			± 1.0	
I_{CC}	Quiescent Supply Current (Timer Inactive)	/SR0 = V_{CC}			1	μA
	Dynamic Supply Current (Timer Active)	/SR0 = 0 V			200	

AC Electrical Characteristics

Conditions of $T_A = -40$ to 80°C with $V_{CC} = 1.8 - 5.0\text{ V}$ OR $T_A = -25$ to 85°C with $V_{CC} = 1.7 - 5\text{ V}$ OR $T_A = 0$ to 85°C with $V_{CC} = 1.65 - 5\text{ V}$ produce the performance characteristics below.

Symbol	Parameter	Condition	Min.	Typ.	Max.	Unit
t_{PHL1}	Timer Delay, /SR0 to RST (DSR=0)	$C_L = 5\text{ pF}$, $R_L = 5\text{ K}\Omega$, see Figure 4	6.0	7.5	9.0	s
t_{REC}	Reset Timeout Delay		320	400	480	ms

Capacitance Specifications

$T_A = +25^\circ\text{C}$.

Symbol	Parameter	Condition	Typ.	Unit
C_{IN}	Input Capacitance	$V_{CC} = \text{GND}$	4	pF
C_{OUT}	Output Capacitance	$V_{CC} = 5.0\text{ V}$	5	pF

Functional Description

Default operation time N is 7.5 s. If the DSR pin is pulled HIGH prior to V_{CC} ramp, the FT7521 enters Test Mode and the reset output, /RST1, is immediately pulled LOW for factory testing. The DSR pin MUST be forced to GND during normal operation. The DSR pin should never be driven HIGH or left to FLOAT during normal operation. The DSR PIN state should never be changed during device operation; it must be biased prior to supplying the V_{CC} supply. If there is a need to use the DSR=VCC Test Mode, the /SR0 must be HIGH when the DSR pin is moved from LOW to HIGH to enter Zero-Second Factory-Test Mode. To return to the standard 7.5-second reset time, the same procedure must be followed with DSR=GND. The DSR pin should never be allowed to change state while the /SR0 pin is LOW. The VCC supply pin should never be left to float while other input pins are driven. If the VCC pin is allowed to float, care should be taken to ensure that /SR0 is not driven to any voltage greater than GND.

Operation Modes

A low input signal on /SR0 starts the oscillator. There are two scenarios for counting: short duration and long duration. In the short-duration scenario, output /RST1 is not affected. In the long-duration scenario, the output

/RST1 goes LOW after /SR0 has been held LOW for ≥ 7.5 s. The /RST1 output returns to its original HIGH state 400ms after time t_{REC} has expired, regardless of the state of /SR0. The /RST1 output is an open-drain driver. When the count time exceeds time 7.5 s, the /RST1 output pulls LOW.

Short Duration ($t_w < 7.5$ s)

When the /SR0 input goes LOW, the internal timer starts counting. If the /SR0 input goes HIGH before 7.5 s has elapsed, the timer stops counting and resets and no changes occur on the outputs.

Long Duration ($t_w > 7.5$ s)

When the /SR0 input goes LOW, the internal timer starts counting. If the /SR0 input stays LOW for at least 7.5 s, the RST output is enabled and pulled LOW. The output RST is held LOW for t_{REC} , 400 ms, as soon as the reset time of 7.5 s is met, regardless of the state of the /SR0 pin. When the /SR0 input has returned HIGH and the t_{REC} has expired, the internal timer resets and awaits the next RESET event.

Zero-Second Test Mode

/RST1 goes LOW immediately after /SR0 goes LOW.

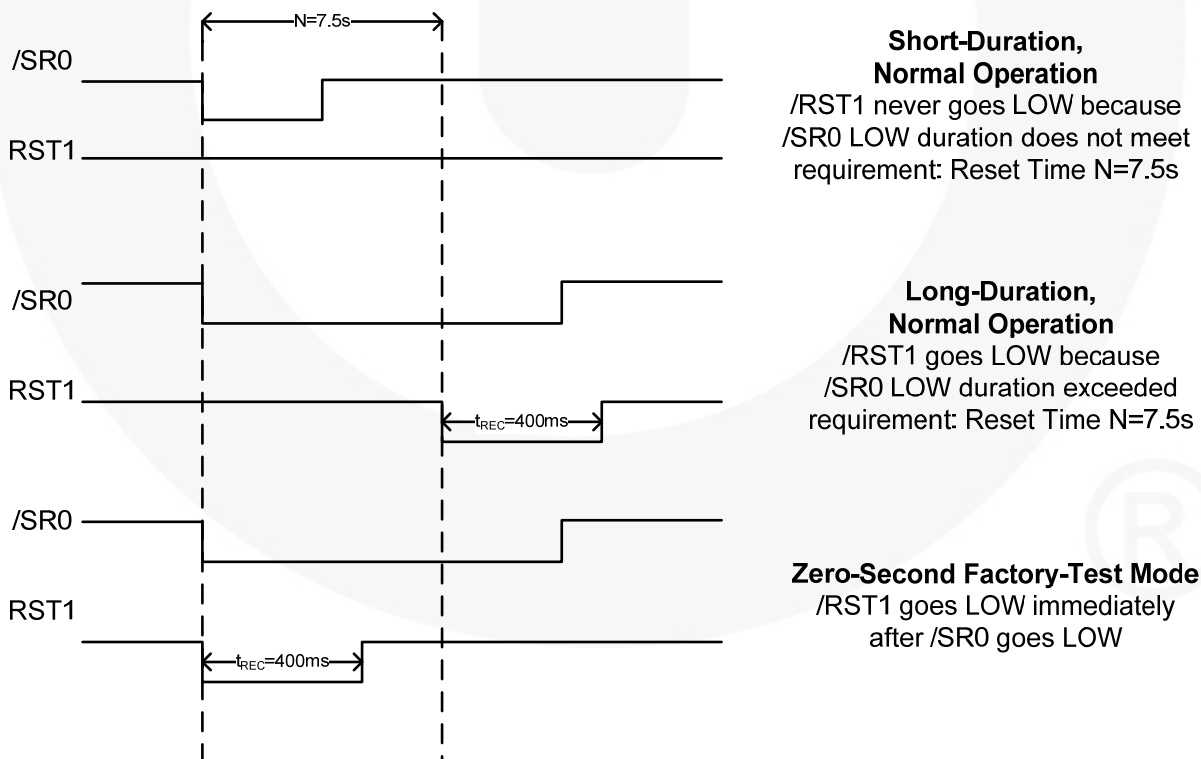

Figure 4. Reset Timing Waveforms

AC Test Circuit and Waveforms

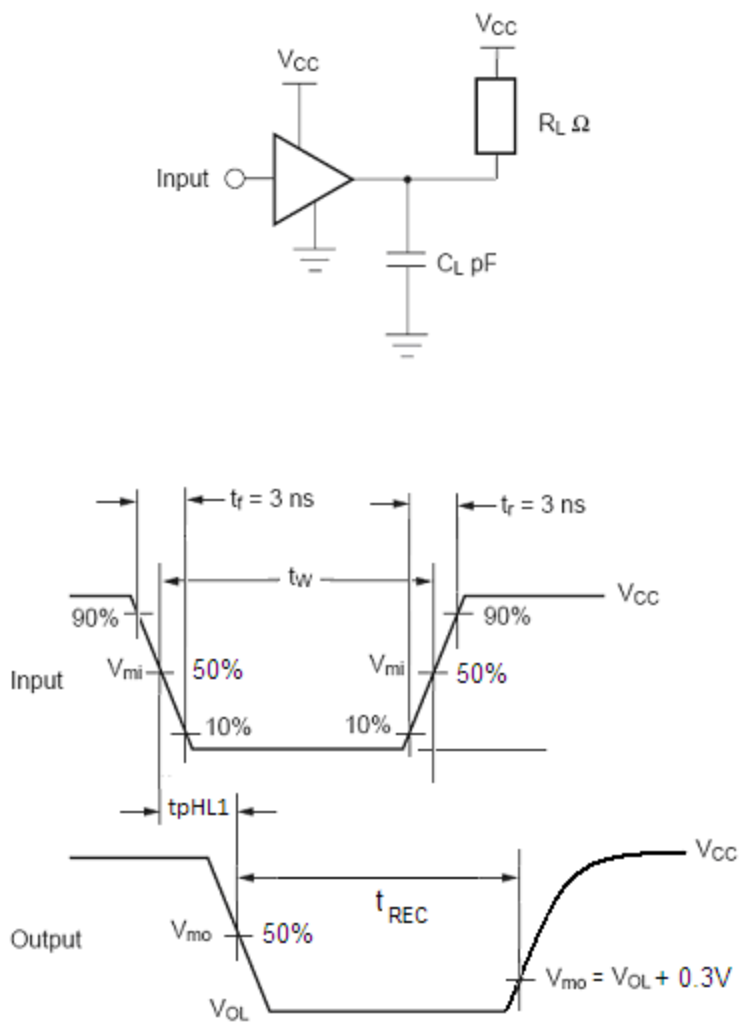

Figure 5. AC Test Circuit and Waveforms for /RST1 Output ST Output



Physical Dimensions

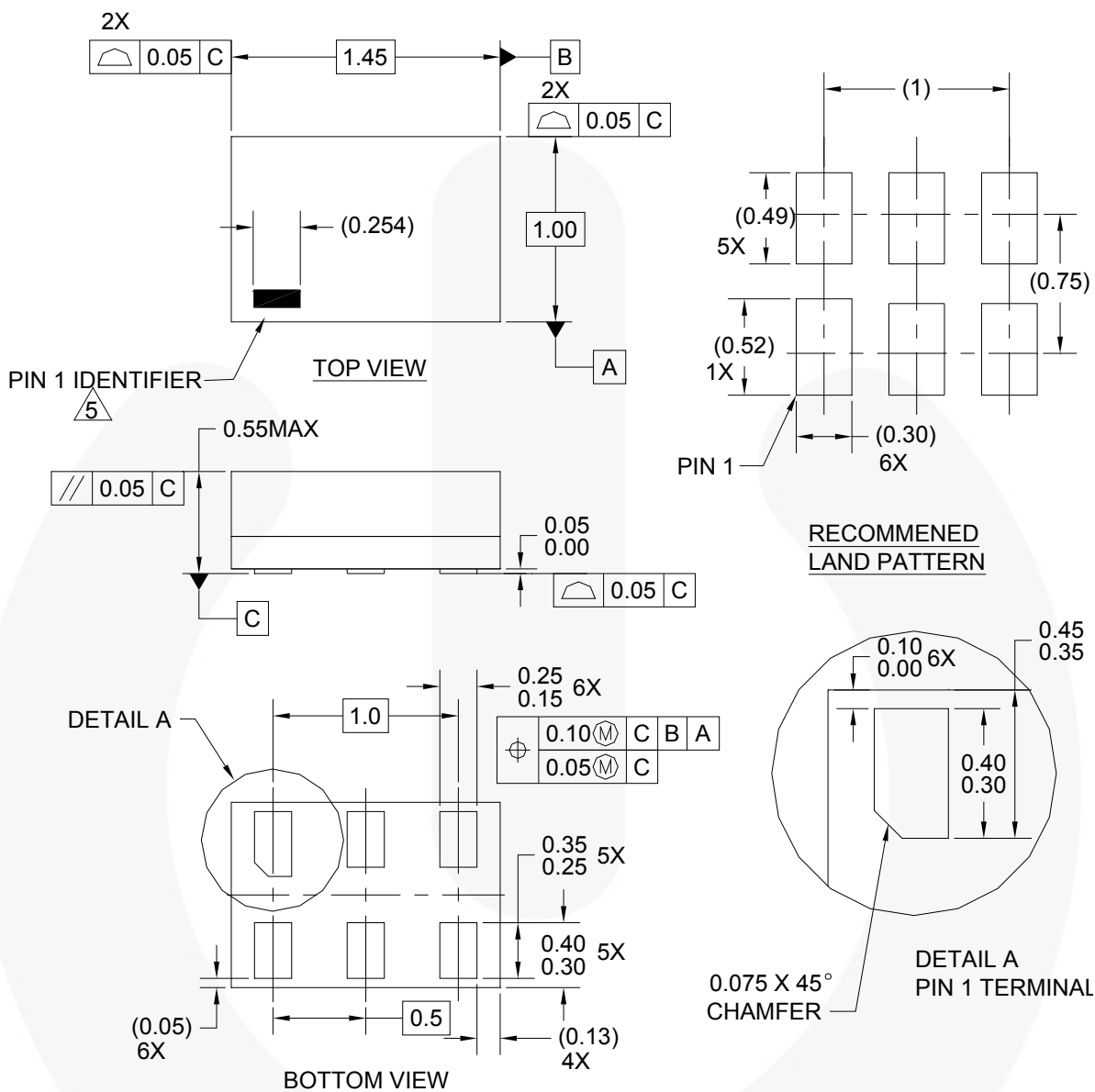

Figure 6. 6-Lead, MicroPak™ 1.0 x 1.45 mm, JEDEC MO-252

Package drawings are provided as a service to customers considering Fairchild components. Drawings may change in any manner without notice. Please note the revision and/or date on the drawing and contact a Fairchild Semiconductor representative to verify or obtain the most recent revision. Package specifications do not expand the terms of Fairchild's worldwide terms and conditions, specifically the warranty therein, which covers Fairchild products.

Always visit Fairchild Semiconductor's online packaging area for the most recent package drawings:
<http://www.fairchildsemi.com/packaging/>

Physical Dimensions

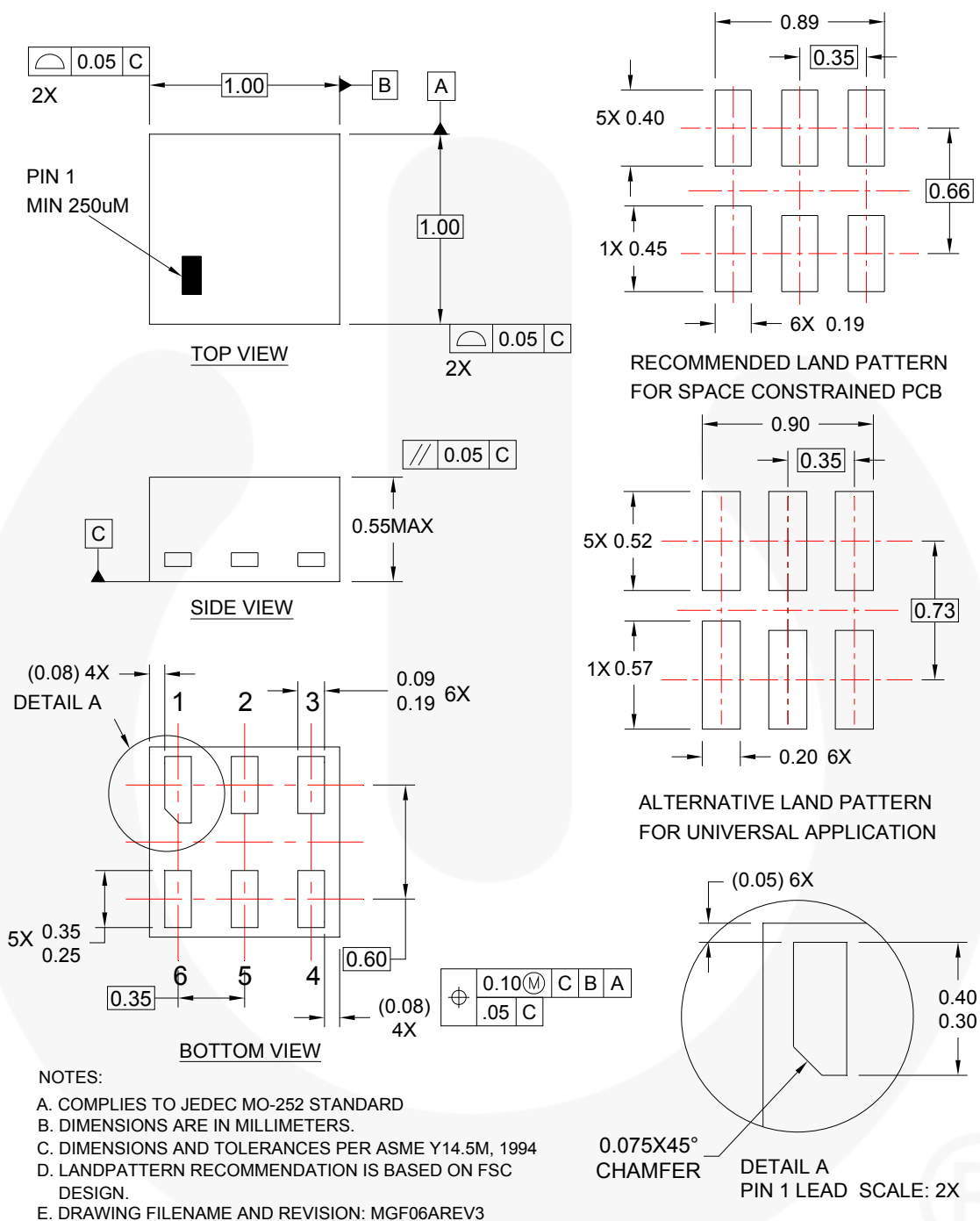

Figure 7. 6-Lead, MicroPak2™ 1.0 x 1.0 mm Body, .35 mm Pitch





Package drawings are provided as a service to customers considering Fairchild components. Drawings may change in any manner without notice. Please note the revision and/or date on the drawing and contact a Fairchild Semiconductor representative to verify or obtain the most recent revision. Package specifications do not expand the terms of Fairchild's worldwide terms and conditions, specifically the warranty therein, which covers Fairchild products.

Always visit Fairchild Semiconductor's online packaging area for the most recent package drawings:
<http://www.fairchildsemi.com/packaging/>



TRADEMARKS

The following includes registered and unregistered trademarks and service marks, owned by Fairchild Semiconductor and/or its global subsidiaries, and is not intended to be an exhaustive list of all such trademarks.

- | | | | |
|--|---|--|---|
| 2Cool™ | F-PFS™ | PowerTrench® | The Power Franchise® |
| AccuPower™ | FRFET® | PowerXS™ | the power franchise |
| AX-CAP™* | Global Power Resource™ | Programmable Active Droop™ | TinyBoost™ |
| BitSiC™ | GreenBridge™ | QFET® | TinyBuck™ |
| Build it Now™ | Green FPS™ | QS™ | TinyCalc™ |
| CorePLUS™ | Green FPS™ e-Series™ | Quiet Series™ | TinyLogic® |
| CorePOWER™ | Gmax™ | RapidConfigure™ | TINYOPTO™ |
| CROSSVOLT™ | GTO™ |  ™ | TinyPower™ |
| CTL™ | IntelliMAX™ | Saving our world, 1mW/W/kW at a time™ | TinyPWM™ |
| Current Transfer Logic™ | ISOPLANAR™ | SignalWise™ | TinyWire™ |
| DEUXPEED® | Making Small Speakers Sound Louder and Better™ | SmartMax™ | TranSiC™ |
| Dual Cool™ | MegaBuck™ | SMART START™ | TriFault Detect™ |
| EcoSPARK® | MICROCOUPLER™ | Solutions for Your Success™ | TRUECURRENT®* |
| EfficientMax™ | MicroFET™ | SPM® | µSerDes™ |
| ESBC™ | MicroPak™ | STEALTH™ |  ™ |
|  Fairchild® | MicroPak2™ | SuperFET® | UHC® |
| Fairchild Semiconductor® | MillerDrive™ | SuperSOT™-3 | Ultra FRFET™ |
| FACT Quiet Series™ | MotionMax™ | SuperSOT™-6 | UniFET™ |
| FACT® | mWSaver™ | SuperSOT™-8 | VCX™ |
| FAST® | OptoHit™ | SupreMOS® | VisualMax™ |
| FastvCore™ | OPTOLOGIC® | SyncFET™ | VoltagePlus™ |
| FETBench™ | OPTOPLANAR® | Sync-Lock™ | XS™ |
| FlashWriter®* |  ™ |  SYSTEM GENERAL®* | |
| FPS™ | | | |

* Trademarks of System General Corporation, used under license by Fairchild Semiconductor.

DISCLAIMER

FAIRCHILD SEMICONDUCTOR RESERVES THE RIGHT TO MAKE CHANGES WITHOUT FURTHER NOTICE TO ANY PRODUCTS HEREIN TO IMPROVE RELIABILITY, FUNCTION, OR DESIGN. FAIRCHILD DOES NOT ASSUME ANY LIABILITY ARISING OUT OF THE APPLICATION OR USE OF ANY PRODUCT OR CIRCUIT DESCRIBED HEREIN; NEITHER DOES IT CONVEY ANY LICENSE UNDER ITS PATENT RIGHTS, NOR THE RIGHTS OF OTHERS. THESE SPECIFICATIONS DO NOT EXPAND THE TERMS OF FAIRCHILD'S WORLDWIDE TERMS AND CONDITIONS, SPECIFICALLY THE WARRANTY THEREIN, WHICH COVERS THESE PRODUCTS.

LIFE SUPPORT POLICY

FAIRCHILD'S PRODUCTS ARE NOT AUTHORIZED FOR USE AS CRITICAL COMPONENTS IN LIFE SUPPORT DEVICES OR SYSTEMS WITHOUT THE EXPRESS WRITTEN APPROVAL OF FAIRCHILD SEMICONDUCTOR CORPORATION.

As used herein:

1. Life support devices or systems are devices or systems which, (a) are intended for surgical implant into the body or (b) support or sustain life, and (c) whose failure to perform when properly used in accordance with instructions for use provided in the labeling, can be reasonably expected to result in a significant injury of the user.
2. A critical component in any component of a life support, device, or system whose failure to perform can be reasonably expected to cause the failure of the life support device or system, or to affect its safety or effectiveness.

ANTI-COUNTERFEITING POLICY

Fairchild Semiconductor Corporation's Anti-Counterfeiting Policy. Fairchild's Anti-Counterfeiting Policy is also stated on our external website, www.fairchildsemi.com, under Sales Support.

Counterfeiting of semiconductor parts is a growing problem in the industry. All manufacturers of semiconductor products are experiencing counterfeiting of their parts. Customers who inadvertently purchase counterfeit parts experience many problems such as loss of brand reputation, substandard performance, failed applications, and increased cost of production and manufacturing delays. Fairchild is taking strong measures to protect ourselves and our customers from the proliferation of counterfeit parts. Fairchild strongly encourages customers to purchase Fairchild parts either directly from Fairchild or from Authorized Fairchild Distributors who are listed by country on our web page cited above. Products customers buy either from Fairchild directly or from Authorized Fairchild Distributors are genuine parts, have full traceability, meet Fairchild's quality standards for handling and storage and provide access to Fairchild's full range of up-to-date technical and product information. Fairchild and our Authorized Distributors will stand behind all warranties and will appropriately address any warranty issues that may arise. Fairchild will not provide any warranty coverage or other assistance for parts bought from Unauthorized Sources. Fairchild is committed to combat this global problem and encourage our customers to do their part in stopping this practice by buying direct or from authorized distributors.

PRODUCT STATUS DEFINITIONS

Definition of Terms

Datasheet Identification	Product Status	Definition
Advance Information	Formative / In Design	Datasheet contains the design specifications for product development. Specifications may change in any manner without notice.
Preliminary	First Production	Datasheet contains preliminary data; supplementary data will be published at a later date. Fairchild Semiconductor reserves the right to make changes at any time without notice to improve design.
No Identification Needed	Full Production	Datasheet contains final specifications. Fairchild Semiconductor reserves the right to make changes at any time without notice to improve the design.
Obsolete	Not In Production	Datasheet contains specifications on a product that is discontinued by Fairchild Semiconductor. The datasheet is for reference information only.

Rev. I62