

## 1 Introduction

---

This document describes the embedded firmware found in all derivatives of the FXTH87xx22 device.

The intended audience for this document is firmware architects, developers, coders and testers working with the FXTH87xx22 device.

Firmware for the FXTH87xx22 is derived directly from MPXY86xx's Firmware Rel04. Known bugs are carried over, and noted in this document when appropriate.

This document is divided into three sections: This introduction, a section describing global variables and standard formats used throughout the functions, and a third section describing each function.

## 2 Globals and formats

---

### 2.1 Global variables

#### 2.1.1 TPMS\_INTERRUPT\_FLAG

The TPM1Ch0 and TPM1Ch1 interrupt vectors are exchanged compared to what is defined in the product specification. This implies that upon interrupt of TPM1Ch0 the user interrupt vector Vtpm1ch1 located at address \$DFF2:DFF3 will be accessed. And upon interrupt of TPM1Ch1 the user interrupt vector Vtpm1ch0 located at address \$DFF4:DFF5 will be accessed.

This global variable keeps track of interrupts that have occurred. FXTH87xx22 Embedded Firmware uses it to keep track of expected interrupts. It can also be utilized by the user for its own purposes. If an LFR interrupt occurs while a firmware function is under execution, the LFR User Interrupt Vector will not be accessed, and the bit 2 ([Table 1](#)) will be the only indication available. Users should check this bit, either prior to entering the firmware function or after the firmware function, to assure LF interrupts are not missed. Also, a number of firmware functions utilize the Stop1 or Stop4 modes, which disable the hardware watchdog block. In order to provide a back-up recovery, users should utilize either the RTI or PWU which can be programmed for interrupt if a software or firmware routine has consumed too much time. The watchdog is automatically restarted when the program goes back in RUN mode.

The TPMS\_INTERRUPT\_FLAG is not cleared automatically. Users must clear this variable after power-on-reset.

[Table 1](#) shows the TPMS\_INTERRUPT\_FLAG format. The trigger condition column describes what is necessary for that flag to be set.



**Table 1. TPMS\_INTERRUPT\_FLAG format and trigger conditions**

Flag	Bit	Trigger condition
LVD Interrupt	7	LVD interrupt entered.
PWU Interrupt	6	PWU interrupt entered.
TOF Interrupt	5	TOF interrupt entered.
LFR Error Interrupt	4	LFR interrupt entered and LFERF bit of the LFS register is set.
ADC Interrupt	3	ADC interrupt entered.
LFR Interrupt	2	LFR interrupt entered and LFERF bit of the LFS register is clear.
RTI Interrupt	1	RTI interrupt entered.
KBI Interrupt	0	KBI interrupt entered.

TPMS\_INTERRUPT\_FLAG is 1 byte long and is located at address \$8F. Users must account for this variable when developing for the FXTH87xx22.

## 2.2 Measurement error format

### 2.2.1 Definition of Signal Ranges

Each measured parameter (pressure, voltage, temperature, and acceleration) results from an ADC conversion of an analog signal. This ADC result may then be passed by the firmware to the application software as either the raw ADC result or further compensated and scaled for an output between one and the maximum digital value minus one. The minimum digital value of zero and the maximum digital value are reserved as error codes.

The signal ranges and their significant data points are shown in [Figure 1](#). In this definition the signal source would normally output a signal between  $S_{INLO}$  and  $S_{INHI}$ . Due to process, temperature and voltage variations this signal may increase its range to  $S_{INMIN}$  to  $S_{INMAX}$ . In all cases the signal will be between the supply rails, so that the ADC will convert it to a range of digital numbers between 0 and 1023 (or 0 and 4095 in the case of temperature readings). These digital numbers will have corresponding  $D_{INMIN}$ ,  $D_{INLO}$ ,  $D_{INHI}$ , and  $D_{INMAX}$  values. The ADC digital value is taken by the firmware and compensated and scaled to give the required output code range.

Digital input values below  $D_{INMIN}$  and above  $D_{INMAX}$  are immediately flagged as being out of range and generate error bits and the output is forced to the corresponding railed-high or railed-low values.

Digital values below  $D_{INLO}$  (but above  $D_{INMIN}$ ) or above  $D_{INHI}$  (but not  $D_{INMAX}$ ) will most likely cause an output that would be less than 1 or greater than 510, respectively. These cases are considered underflow or overflow, respectively. Underflow results will be forced to a value of 1. Overflow results will be forced to a value of 510.

Digital values between  $D_{INLO}$  and  $D_{INHI}$  will normally produce an output between 1 to 510 (for a 9-bit result). In some isolated cases due to compensation calculations and rounding the result may be less than 1 or greater than 510, in which case the underflow and overflow rule mentioned above is used.

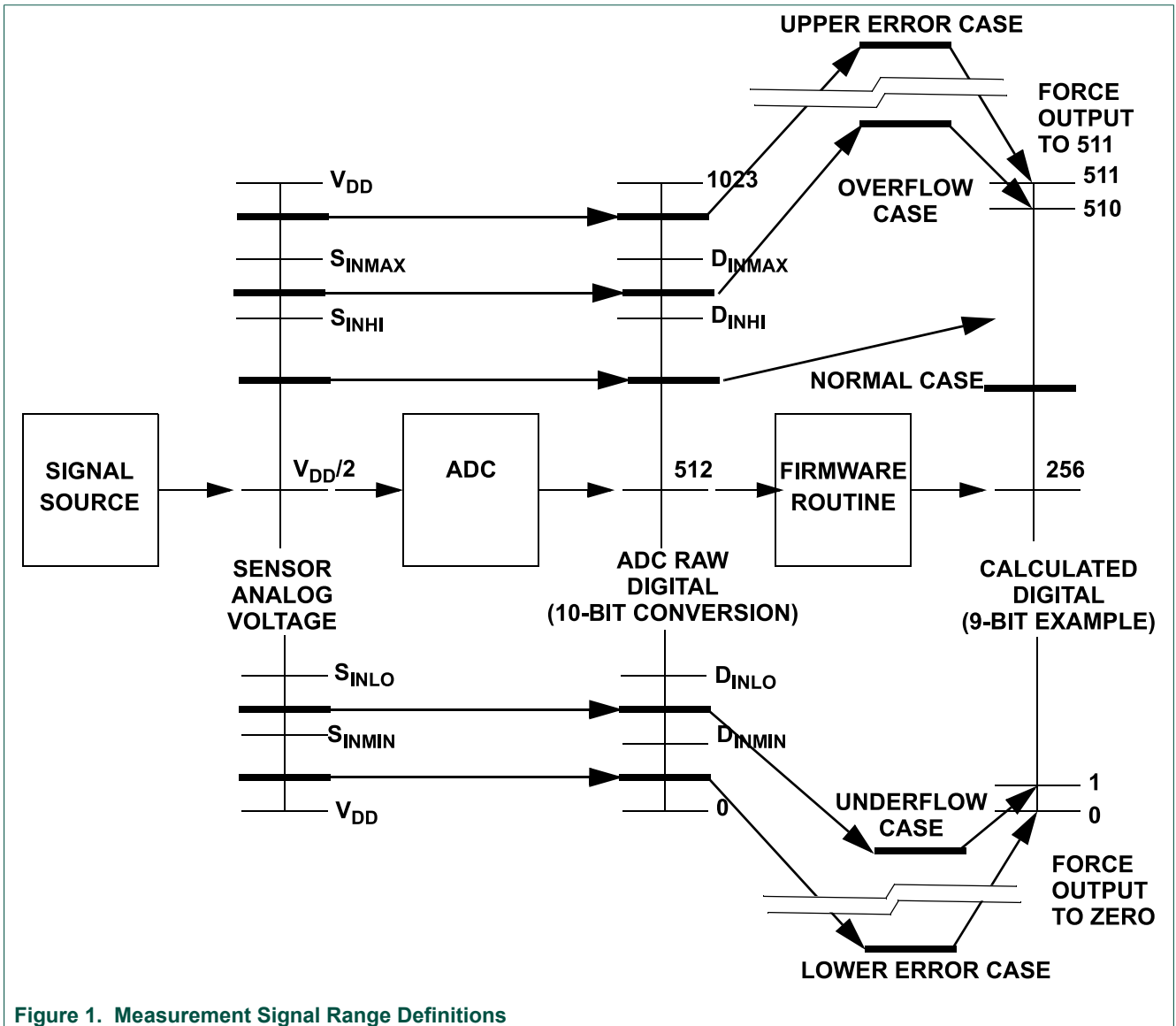

Figure 1. Measurement Signal Range Definitions

### 2.2.2 Error Status Format

FXTH87xx22 Embedded Firmware functions that return a status byte commonly do so using the error fields described in [Table 2](#).

Table 2. Error Status Fields

Field	Description
BIT7 - ADCERR	<p><b>ADC Error</b> — This status bit indicates an error was detected when performing an ADC test within the TPMS_WIRE_AND_ADC_CHECK routine.</p> <p><b>0</b> — ADC operating as expected.</p> <p><b>1</b> — ADC returned unexpected reading.</p>

Field	Description
BIT6 – TERR	<p><b>Temperature Measurement Error</b> — This status bit indicates an error was detected by a ADC reading of the temperature sensor that is outside of the normally accepted range.</p> <p><b>0</b> — Temperature error not detected in last firmware subroutine call.  <b>1</b> — Temperature error detected in last firmware subroutine call.</p>
BIT5 – VERR	<p><b>Voltage Measurement Error</b> — This status bit indicates an error was detected by a ADC reading of the voltage reference that is outside of the normally accepted range.</p> <p><b>0</b> — Voltage error not detected in last firmware subroutine call.  <b>1</b> — Voltage error detected in last firmware subroutine call.</p>
BIT4 – AZERR	<p><b>Z-Axis Accelerometer Measurement Error (if applicable)</b> — This status bit indicates an error was detected by a bonding wire failure to the g-cell or a ADC reading of the Z-axis accelerometer that is outside of the normally accepted range.</p> <p><b>0</b> — Acceleration error not detected in last firmware subroutine call.  <b>1</b> — Acceleration error detected in last firmware subroutine call.</p>
BIT3 – AXERR	<p><b>X-Axis Accelerometer Measurement Error (if applicable)</b> — This status bit indicates an error was detected by a bonding wire failure to the g-cell or a ADC reading of the X-axis accelerometer that is outside of the normally accepted range.</p> <p><b>0</b> — Acceleration error not detected in last firmware subroutine call.  <b>1</b> — Acceleration error detected in last firmware subroutine call.</p>
BIT2 – PERR	<p><b>Pressure Measurement Error</b> — This status bit indicates an error was detected by a parity fault in the P-Chip trim, bonding wire failure to the P-Chip or a ADC reading of the pressure that is outside of the normally accepted range.</p> <p><b>0</b> — Pressure error not detected in last firmware subroutine call.  <b>1</b> — Pressure error detected in last firmware subroutine call.</p>
BIT1 – BONDERR	<p><b>Bond Wire Error</b> — This status bit indicates an error was detected in any of the bond wire checks of the g-cell or P-cell.</p> <p><b>0</b> — Bond wire error not detected in last firmware subroutine call.  <b>1</b> — Bond wire error detected in last firmware subroutine call.</p>
BIT0 – OVFLOW	<p><b>Calculation Overflow/Underflow</b> — This status bit indicates that a compensated measurement of pressure, temperature, voltage or acceleration resulted in a digital output code outside of the expected range. The output value will be clipped to the nearest highest or lowest allowed value and the status bit will be set.</p> <p><b>0</b> — Overflow/underflow not detected in last firmware subroutine call.  <b>1</b> — Overflow/underflow detected in last firmware subroutine call.</p>

### 2.3 Universal Uncompensated Measurement Array (UUMA) format

The FXTH87xx22's measurement routines are divided into two subsets: routines that return uncompensated measurements, and routines that take uncompensated measurements as arguments and return compensated measurements.

In order to be consistent and keep the number of CPU cycles down, all uncompensated measurement routines will return data following the array format described in [Table 3](#), and all compensating routines will take data from the same array.

**Table 3. Universal Uncompensated Measurement Array**

Index	Content
0	Uncompensated voltage
1	Uncompensated temperature
2	Uncompensated pressure
3	Uncompensated X-Axis acceleration
4	Uncompensated Z-Axis acceleration

This array is referred to as Universal Uncompensated Measurement Array (UUMA). It can be located anywhere the user decides.

Each element must be 16-bits long (two bytes) regardless of what the actual bit-width of the measurement is.

Each individual uncompensated measurement routine will only update its corresponding item. For example, calling the TPMS\_READ\_VOLTAGE routine will only modify the voltage element of the array. The rest will remain unchanged.

Compensation routines do not modify any elements in the UUMA.

## 2.4 Simulated SPI interface Signal Format

The FXTH87xx22 includes three routines (TPMS\_MSG\_INIT, TPMS\_MSG\_READ and TPMS\_MSG\_WRITE) that, when used together, allow the user to perform serial communication with the device through a simulated SPI interface.

The following assumptions are made:

- Only two pins are used: PTA0 for data (both incoming and outgoing) and PTA1 for clock. No slave select is included by default, but the user may use any other pin if required.
- The data pin has a pullup resistor enabled.
- The FXTH87xx22 will be a master device (the FXTH87xx22 will provide the clock).
- Data can be read/written eight bits at a time.
- Speed of the interface is dependant on bus clock settings.
- Data is transferred MSB first.
- A single line will be used for both sending and receiving data (BIDIROE = SET according to NXP nomenclature).
  - At the clock's rising edge, the master will place data on the pin. It will be valid until the clock's falling edge. The slave must not drive the line during this period.
  - At the clock's falling edge, the master will make the data pin an input and will "listen" for data. The slave must then place data on the data line until the clock's rising edge.
- Clock Polarity = 0 (Normally low).
- Clock Phase = 1 (First half is high).

[Figure 2](#) shows the details of the simulated SPI interface.

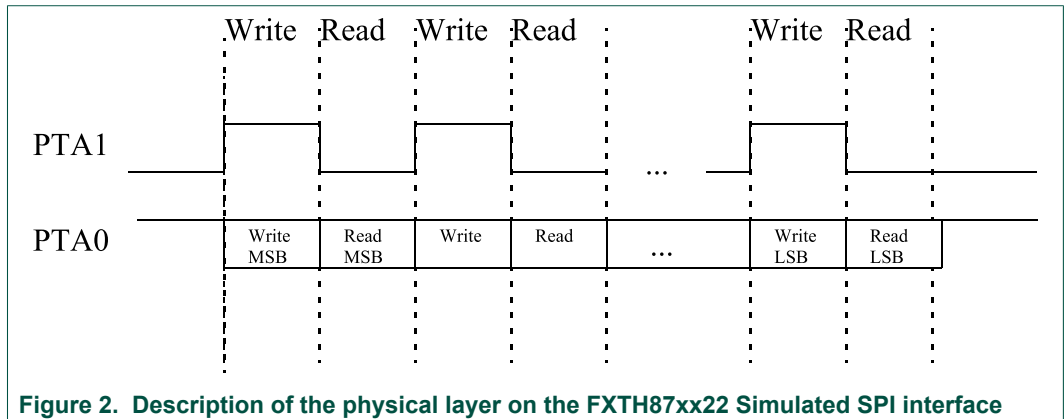

**Figure 2. Description of the physical layer on the FXTH87xx22 Simulated SPI interface**

For further information on the use of the Simulated SPI interface routines, refer [Section 3.2.30](#), [Section 3.2.31](#), and [Section 3.2.32](#).

## 2.5 Rapid Decompression Event Array (T\_RDE) Format

The FXTH87xx22 includes a routine called TPMS\_RDE\_ADJUST\_PRESSURE that requires a pointer to an array of elements using a custom format called T\_RDE. Said format is easily manageable using a typedef instruction as shown in Example 1.

### Example 1. Sample typedef for a T\_RDE array

```
typedef struct
{
    UINT16 u16CompPress;      /* I/O 9-bit Compensated pressure reading */
    UINT8  u8ElapsedTime;    /* I Elapsed time from previous reading */
    UINT16 u16WAvg;         /* O Weighed average for running pressure */
    UINT8  u8PRes;          /* O 8-bit pressure reserve value */
    UINT8  u8PMin;          /* O 8-bit minimum pressure value */
    UINT8  u8RDEStatusFlags; /* O Contains flags for Clock and RDE Event */
    UINT16 u16RDEBailTimeOut; /* O Seconds to 60 mins bail-out */
    UINT8  u8RDETimeToAvg;  /* O Seconds to next averaging event */
} T_RDE;
```

As shown by the comments, only the u16CompPress and u8ElapsedTime elements of this array should be edited by the user; the rest will be updated by the TPMS\_RDE\_ADJUST\_PRESSURE function.

In order for TPMS\_RDE\_ADJUST\_PRESSURE to work correctly, the T\_RDE variable must be declared as a global and must reside in an NVM location.

For more information on TPMS\_RDE\_ADJUST\_PRESSURE, refer to [Section 3.2.47](#).

## 2.6 LFR registers initialized by firmware

Some LFR registers are touched by firmware when taking the reset vector and before giving control to the user. The goal of this action is to configure the LFR module in the best-known configuration for Manchester-encoded reception.

LFR registers will be configured differently depending on the user-selected sensitivity. [Table 4](#) and [Table 5](#) describe these settings.

**Table 4. Customer-configurable TMP5 and LF Register with SENS = 1**

Page-0	Bit name							
Register name	7	6	5	4	3	2	1	0
LFCTL1	LFEN	SRES	CARMOD	PAGE	IDSEL		SENS	
LFCTL2	LFSTM				LFONTM			
LFCTL3	LFDO	TOGMOD	SYNC		LFCDTM			
LFCTL4	LFDRIE	LFERIE	LFCDIE	LFIDIE	DECEN	VALEN	TIMOUT	
LFS	LFDRF	LFERF	LFCDF	LFIDF	LFOVF	LFEOMF	LPSM	LFIK
LFDATA	RXDATA							
LFIDL	ID7	ID6	ID5	ID4	ID3	ID2	ID1	ID0
LFIDH	ID15	ID14	ID13	ID12	ID11	ID10	ID9	ID8

Page-1	Bit name							
Register name	7	6	5	4	3	2	1	0
LFCTL1	LFEN	SRES	CARMOD	PAGE	IDSEL		SENS = 2	
LFCTRLE	—	—	—	—	—	0	0	0
LFCTRLD	1	0	DEQS	1	1	1	0	1
LFCTRLC	0	0	0	1	AZEN	LOWQ		DEQEN
LFCTRLB	1	1	LFFAF	LFCAF	LFPOL	1	1	0
LFCTRLA	—	—	—	—	LFCC			
TRIM1	—	—	—	—	—	—	—	—
TRIM2	—	—	—	—	—	—	—	—

Shaded cells show register touched by firmware; loaded value is displayed.

**Table 5. Customer-configurable TMP5 and LF Register with SENS = 2**

Page-0	Bit name							
Register name	7	6	5	4	3	2	1	0
LFCTL1	LFEN	SRES	CARMOD	PAGE	IDSEL		SENS	
LFCTL2	LFSTM				LFONTM			
LFCTL3	LFDO	TOGMOD	SYNC		LFCDTM			
LFCTL4	LFDRIE	LFERIE	LFCDIE	LFIDIE	DECEN	VALEN	TIMOUT	
LFS	LFDRF	LFERF	LFCDF	LFIDF	LFOVF	LFEOMF	LPSM	LFIK
LFDATA	RXDATA							
LFIDL	ID7	ID6	ID5	ID4	ID3	ID2	ID1	ID0
LFIDH	ID15	ID14	ID13	ID12	ID11	ID10	ID9	ID8

Page-1	Bit name							
Register name	7	6	5	4	3	2	1	0
LFCTL1	LFEN	SRES	CARMOD	PAGE	IDSEL		SENS = 2	
LFCTRLE	—	—	—	—	—	0	0	0
LFCTRLD	1	0	DEQS	1	1	1	0	1

Page-1	Bit name							
Register name	7	6	5	4	3	2	1	0
LFCTRLC	0	0	0	1	AZEN	LOWQ		DEQEN
LFCTRLB	1	1	LFFAF	LFCAF	LFPOL	1	1	0
LFCTRLA	—	—	—	—	LFCC			
TRIM1	—	—	—	—	—	—	—	—
TRIM2	—	—	—	—	—	—	—	—

Shaded cells show register touched by firmware; loaded value is displayed.

### 3 Firmware Functions

#### 3.1 Firmware jump table

The FXTH87xx22 device contains an embedded firmware function jump table to allow programmers to reference any function through a function pointer to an absolute address. This helps isolate NXP firmware from the user's application. [Table 6](#) shows a list of all firmware functions, their address, and to which FXTH87xx22 derivative they apply.

For a description of how to implement pointers to fixed addresses using the C language, please refer to Manual\_Compiler\_HC08.pdf (part of the CodeWarrior package).

**Table 6. FXTH87xx22's Firmware Function jump table**

Absolute Address	Return type	Function	Reference
\$E000	void	TPMS_RESET	<a href="#">Section 3.2.1</a>
\$E003	UINT8	TPMS_READ_VOLTAGE	<a href="#">Section 3.2.2</a>
\$E006	UINT8	TPMS_COMP_VOLTAGE	<a href="#">Section 3.2.3</a>
\$E009	UINT8	TPMS_READ_TEMPERATURE	<a href="#">Section 3.2.4</a>
\$E00C	UINT8	TPMS_COMP_TEMPERATURE	<a href="#">Section 3.2.5</a>
\$E00F	UINT8	TPMS_READ_PRESSURE	<a href="#">Section 3.2.6</a>
\$E012	UINT8	TPMS_COMP_PRESSURE	<a href="#">Section 3.2.7</a>
\$E015	UINT8	TPMS_READ_ACCELERATION_X	<a href="#">Section 3.2.8</a>
\$E018	UINT8	TPMS_READ_DYNAMIC_ACCEL_X	<a href="#">Section 3.2.9</a>
\$E01B	UINT8	TPMS_COMP_ACCELERATION_X	<a href="#">Section 3.2.10</a>
\$E01E	UINT8	TPMS_READ_ACCELERATION_Z	<a href="#">Section 3.2.11</a>
\$E021	UINT8	TPMS_READ_DYNAMIC_ACCEL_Z	<a href="#">Section 3.2.12</a>
\$E024	UINT8	TPMS_COMP_ACCELERATION_Z	<a href="#">Section 3.2.13</a>
\$E027	UINT8	TPMS_READ_ACCELERATION_XZ	<a href="#">Section 3.2.14</a>
\$E02A	UINT8	TPMS_READ_DYNAMIC_ACCEL_XZ	<a href="#">Section 3.2.15</a>
\$E02D	UINT8	TPMS_COMP_ACCELERATION_XZ	<a href="#">Section 3.2.16</a>
\$E030	UINT8	TPMS_READ_V0	<a href="#">Section 3.2.17</a>
\$E033	UINT8	TPMS_READ_V1	<a href="#">Section 3.2.18</a>



Absolute Address	Return type	Function	Reference
\$E036	UINT8	TPMS_LFOCAL	<a href="#">Section 3.2.19</a>
\$E039	UINT8	TPMS_MFOCAL	<a href="#">Section 3.2.20</a>
\$E03C	void	TPMS_RF_ENABLE	<a href="#">Section 3.2.21</a>
\$E03F	void	TPMS_RF_RESET	<a href="#">Section 3.2.22</a>
\$E042	void	TPMS_RF_READ_DATA	<a href="#">Section 3.2.23</a>
\$E045	void	TPMS_RF_READ_DATA_REVERSE	<a href="#">Section 3.2.24</a>
\$E048	void	TPMS_RF_WRITE_DATA	<a href="#">Section 3.2.25</a>
\$E04B	void	TPMS_RF_WRITE_DATA_REVERSE	<a href="#">Section 3.2.26</a>
\$E04E	void	TPMS_RF_CONFIG_DATA	<a href="#">Section 3.2.27</a>
\$E051	—	Reserved	—
\$E054	void	TPMS_RF_SET_TX	<a href="#">Section 3.2.28</a>
\$E057	void	TPMS_RF_DYNAMIC_POWER	<a href="#">Section 3.2.29</a>
\$E05A	void	TPMS_MSG_INIT	<a href="#">Section 3.2.30</a>
\$E05D	UINT8	TPMS_MSG_READ	<a href="#">Section 3.2.31</a>
\$E060	UINT8	TPMS_MSG_WRITE	<a href="#">Section 3.2.32</a>
\$E063	UINT8	TPMS_CHECKSUM_XOR	<a href="#">Section 3.2.33</a>
\$E066	UINT8	TPMS_CRC8	<a href="#">Section 3.2.34</a>
\$E069	UINT16	TPMS_CRC16	<a href="#">Section 3.2.35</a>
\$E06C	UINT16	TPMS_SQUARE_ROOT	<a href="#">Section 3.2.36</a>
\$E06F	void	TPMS_READ_ID	<a href="#">Section 3.2.37</a>
\$E072	void	TPMS_LF_ENABLE	<a href="#">Section 3.2.38</a>
\$E075	UINT8	TPMS_LF_READ_DATA	<a href="#">Section 3.2.39</a>
\$E078	UINT8	TPMS_WIRE_AND_ADC_CHECK	<a href="#">Section 3.2.40</a>
\$E07B	void	TPMS_FLASH_WRITE	<a href="#">Section 3.2.41</a>
\$E07E	UINT16	TPMS_FLASH_CHECK	<a href="#">Section 3.2.42</a>
\$E081	UINT8	TPMS_FLASH_ERASE	<a href="#">Section 3.2.43</a>
\$E084	UINT8	TPMS_FLASH_PROTECTION	<a href="#">Section 3.2.44</a>
\$E087	—	Reserved	—
\$E08A	void	TPMS_MULT_SIGN_INT16	<a href="#">Section 3.2.45</a>
\$E08D	UINT16	TPMS_WAVG	<a href="#">Section 3.2.46</a>
E090	UINT8	TPMS_RDE_ADJUST_PRESSURE	<a href="#">Section 3.2.47</a>

## 3.2 Function description

The following function descriptions include stack sizes and approximate duration.

Stack sizes have been calculated by executing each routine and measuring the amount of memory utilized. Unless noted, they represent the maximum stack the function will utilize.

Duration estimates are performed on one part at room temperature. They are intended to serve as a guideline for typical execution time.

### 3.2.1 void TPMS\_RESET (void)

- **Description:** This function is called when taking the reset vector. It will reset the Stack Pointer to the last RAM location and jump to the location stored by the user in \$DFFE:DFFF. No further initialization is performed.
- **Stack size:** 3 bytes
- **Power management:** This function executes entirely in RUN mode.
- **Interrupt management:** This function does not await interrupts. It is not affected by interrupts either.
- **Resources:** Stack
- **Input parameters:**
  - None
- **Returns:**
  - void

### 3.2.2 UINT8 TPMS\_READ\_VOLTAGE (UINT16 \*u16UUMA)

- **Description:** Performs a 10-bit uncompensated voltage measurement and places it in the UUMA. While waiting for the ADC to converge, this function goes into STOP4. If the ADC, for an unexpected reason, fails to converge, this function has a built-in time-out: After five continuous non-ADC interrupts, the function will assume a failed ADC reading, flag it accordingly, and exit.
  - If the ADC value is over or under the normal operating condition, the "voltage error" status flag will be set. The expected voltage result will be forced to either "0" or "1023." (rail high or rail low).
  - If the ADC times out with no result, the "ADC error" status flag will be set.
  - Measurements below 2.1 V are not guaranteed for accuracy.
- **Stack size:** 23 bytes
- **Approx. Duration:** 100  $\mu$ s
- **Power management:** This function requires the core to be configured for STOP4 mode and running at full bus speed.
- **Interrupt management:** This function utilizes the ADC interrupt to wake up from STOP mode.
- **Resources:** ADC, bandgap.
- **Input parameters:**
  - `UINT16 *u16UUMA`: Pointer to Universal Uncompensated Measurement Array (as described in [Section 2.3](#)). Only the 10-bit uncompensated voltage result will be updated.
- **Returns:**
  - `UINT8 u8Status`: Valid error flags/outputs are described in [Table 7](#).

**Table 7. Valid output conditions for TPMS\_READ\_VOLTAGE**

u8Status Value	Measurement Value	Condition
\$20	\$03FF	Uncompensated voltage reading outside of valid range (high).
\$20	\$0000	Uncompensated voltage reading outside of valid range (low).
\$80	Undefined	Uncompensated voltage reading not acquired.
\$00	Between \$0001 - \$03FE	Valid uncompensated voltage reading.

**Warning:** The Bandgap bit (BIT0 in the SPMSC1 register) must be set prior to calling this function for results to be valid.

**3.2.3 UINT8 TPMS\_COMP\_VOLTAGE (UINT8 \*u8CompVoltage, \*UINT16 u16UUMA)**

- **Description:** Performs an 8-bit compensated voltage measurement. It is the user's responsibility to ensure that updated and valid uncompensated voltage reading is available in the UUMA for this routine to return a meaningful value.
  - If  $V_{out} < 2.1\text{ V}$ , u8Voltage will be 1 and the "over/underflow" status flag will be set.
  - Measurements below 2.1 V are not guaranteed for accuracy.
  - If  $V_{out} \geq 3.75\text{ V}$ , result will be \$FE and the "over/underflow" status flag will be set.
  - For repeatability data, refer to the FXTH87x06 data sheet.
- **Stack size:** 31 bytes
- **Approx. Duration:** 216  $\mu\text{s}$
- **Power management:** This function executes entirely in RUN mode.
- **Interrupt management:** This function does not await interrupts. It is not affected by interrupts either.
- **Resources:** UUMA
- **Input parameters:**
  - UINT8 \*u8Voltage: Updated 8-bit compensated voltage result.
  - UINT16 \*u16UUMA: Pointer to Universal Uncompensated Measurement Array (as described in [Section 2.3](#)). Uncompensated voltage will be utilized from this array.
- **Returns:**
  - UINT8 u8Status: Valid error flags/outputs are described in [Table 8](#).

**Table 8. Valid output conditions for TPMS\_COMP\_VOLTAGE**

u8Status Value	Measurement Value	Condition
\$01	\$FE	Compensated voltage reading outside of valid range (high).
\$01	\$01	Compensated voltage reading outside of valid range (low).
\$00	Between \$01 – \$FE	Valid compensated voltage reading.

**3.2.4 UINT8 TPMS\_READ\_TEMPERATURE (UINT16 \*u16UUMA)**

- **Description:** Performs a 12-bit uncompensated temperature measurement and places it in the UUMA. While waiting for the ADC to converge, this function goes into STOP4. If the ADC, for an unexpected reason, fails to converge, this function has a built-in time-out: After five continuous non-ADC interrupts, the function will assume a failed ADC reading, flag it accordingly, and exit.
  - If the ADC value is over or under the normal operating condition, the "temperature error" status flag will be set. The expected temperature result will be forced to either "0" or "4095." (rail high or rail low). If the Low Voltage Warning Flag (LVWF) hardware bit is set, it will flag it accordingly as well.
  - If the ADC value is over or under the normal operating condition, the "temperature error" status flag will be set. The expected temperature result will be forced to either "0" or "4095." (rail high or rail low).
  - If the ADC times out with no result, the "ADC error" status flag will be set.
- **Stack size:** 18 bytes
- **Approx. Duration:** 219 μs
- **Power management:** This function requires the core to be configured for STOP4 mode and running at full bus speed.
- **Interrupt management:** This function utilizes the ADC interrupt to wake up from STOP mode.
- **Resources:** ADC, bandgap.
- **Input parameters:**
  - `UINT16 *u16UUMA`: Pointer to Universal Uncompensated Measurement Array (as described in [Section 2.3](#)). Only the 12-bit uncompensated temperature result will be updated.
- **Returns:**
  - `UINT8 u8Status`: Valid error flags/outputs are described in [Table 9](#).

**Table 9. Valid output conditions for TPMS\_READ\_TEMPERATURE**

<b>u8Status Value</b>	<b>Measurement Value</b>	<b>Condition</b>
\$40	\$0FFF	Uncompensated temperature reading outside of valid range (high).
\$40	\$0000	Uncompensated temperature reading outside of valid range (low).
\$60	\$0FFF	Uncompensated temperature reading outside of valid range (high), and LVWF set.
\$60	\$0000	Uncompensated temperature reading outside of valid range (low), and LVWF set.
\$80	Undefined	Uncompensated temperature reading not acquired.
\$A0	Undefined	Uncompensated temperature reading not acquired, and LVWF set.
\$00	Between \$0001 – \$0FFE	Valid uncompensated temperature reading.
\$20	Between \$0001 – \$0FFE	Valid uncompensated temperature reading, LVWF set.

**Warning:** The Bandgap bit (*BIT0* in the *SPMSC1* register) must be set prior to calling this function for results to be valid.

**3.2.5 UINT8 TPMS\_COMP\_TEMPERATURE (UINT8 \*u8Temp, UINT16 \*u16UUMA)**

- **Description:** Performs an 8-bit compensated temperature measurement. It is the user's responsibility to ensure that updated and valid uncompensated temperature reading is available in the UUMA for this routine to return a meaningful value.
  - If Tout < -40°C, u8Temp will be 1 and the "over/underflow" status flag will be set.
  - If Tout ≥ 200°C, u8Temp will be \$FE and the "over/underflow" status flag will be set.
- **Stack size:** 30 bytes
- **Approx. Duration:** 231 μs
- **Power management:** This function executes entirely in RUN mode.
- **Interrupt management:** This function does not await interrupts. It is not affected by interrupts either.
- **Resources:** UUMA
- **Input parameters:**
  - UINT8 \*u8Temp: Updated 8-bit compensated temperature result.
  - UINT16 \*u16UUMA: Pointer to Universal Uncompensated Measurement Array (as described in [Section 2.3](#)). Uncompensated temperature will be utilized from this array.
- **Returns:**
  - UINT8 u8Status: Valid error flags/outputs are described in [Table 10](#).

**Table 10. Valid output conditions for TPMS\_COMP\_TEMPERATURE**

u8Status Value	Measurement Value	Condition
\$01	\$FE	Compensated temperature reading outside of valid range (high).
\$01	\$01	Compensated temperature reading outside of valid range (low).
\$00	Between \$01 – \$FE	Valid compensated temperature reading.

**3.2.6 UINT8 TPMS\_READ\_PRESSURE (UINT16 \*u16UUMA, UINT8 u8Avg)**

- **Description:** Performs an 10-bit uncompensated pressure measurement and places it in the UUMA. While waiting for the ADC to converge, this function goes into STOP4. If the ADC, for an unexpected reason, fails to converge, this function has a built-in time-out: After five continuous non-ADC interrupts, the function will assume a failed ADC reading, flag it accordingly, and exit. If the LVWF (Low Voltage Warning Flag) hardware bit is set, it will flag it accordingly as well.
  - If the ADC value is over or under the normal operating condition, the "pressure error" status flag will be set. The expected pressure result will be forced to either "0" or "1023." (rail high or rail low).
  - If the ADC times out with no result, the "ADC error" status flag will be set.
- **Stack size:** 28 bytes
- **Approx. Duration:** 2848 μs (avg of 1); 3064 μs (avg of 4).
- **Power management:** This function requires the core to be configured for STOP4 mode and running at full bus speed.
- **Interrupt management:** This function utilizes the ADC interrupt to wake up from STOP mode.
- **Resources:** SMI, ADC, internal bond wires.

- **Input parameters:**
  - UINT16 \*u16UUMA: Pointer to Universal Uncompensated Measurement Array (as described in [Section 2.3](#)). Only the 10-bit uncompensated pressure result will be updated.
  - UINT8 u8Avg: Number of measurements to average into one result. The value can be set to 1, 2, 4, 8, or 16.
- **Returns:**
  - UINT8 u8Status: Valid error flags/outputs are described in [Table 11](#).

**Table 11. Valid output conditions for TPMS\_READ\_PRESSURE**

u8Status Value	Measurement Value	Condition
\$04	\$03FF	Uncompensated pressure reading outside of valid range (high).
\$04	\$0000	Uncompensated pressure reading outside of valid range (low).
\$24	\$03FF	Uncompensated pressure reading outside of valid range (high), and LVWF set.
\$24	\$0000	Uncompensated pressure reading outside of valid range (low), and LVWF set.
\$80	\$0000	Uncompensated pressure reading not acquired
\$A0	\$0000	Uncompensated pressure reading not acquired, and LVWF set.
\$00	Between \$0001 – \$03FE	Valid uncompensated pressure reading.
\$00	Between \$0001 – \$03FF	Valid uncompensated pressure reading, and LVWF set.

**3.2.7 UINT8 TPMS\_COMP\_PRESSURE (UINT16 \*u16CompPressure, UINT16 \*u16UUMA)**

- **Description:** Performs an 9-bit compensated pressure measurement. It is the user's responsibility to ensure that updated and valid uncompensated voltage, temperature and pressure readings are available in the UUMA for this routine to return a meaningful value.
  - If either the temperature or supply voltage measurements inherent to this function result in a fault, the pressure reading will be forced to 0 and the appropriate pressure, temperature and/or voltage flags will be set in the status flag.
  - If Pout < 100 kPa, the "over/underflow" status flag will be set, and u16CompPressure will be forced to \$001.
  - If Pout ≥ 900 kPa, u16CompPressure will be \$1FE and the "over/underflow" status flag will be set.
  - If the passed uncompensated voltage measurement is estimated to be under the guaranteed operational region, the routine will set the "Voltage" status flag. The accuracy of the returned value is not guaranteed.
  - For repeatability data, refer to the FXTH87x06 data sheet.
- **Stack size:** 46 bytes
- **Approx. Duration:** 900 μs
- **Power management:** This function executes entirely in RUN mode.

- **Interrupt management:** This function does not await interrupts. It is not affected by interrupts either.
- **Resources:** UUMA
- **Input parameters:**
  - UINT16 \*u16Pressure: Updated 9-bit compensated pressure result.
  - UINT16 \*u16UUMA: Pointer to Universal Uncompensated Measurement Array (as described in [Section 2.3](#)). Uncompensated voltage, temperature and pressure will be taken from this array.
- **Returns:**
  - UINT8 u8Status: Valid error flags/outputs are described in [Table 12](#).

**Table 12. Valid output conditions for TPMS\_COMP\_PRESSURE**

u8Status Value	Measurement Value	Condition
\$01	\$01FE	Compensated pressure reading outside of valid range (high).
\$01	\$0001	Compensated pressure reading outside of valid range (low).
\$21	\$01FE	Compensated pressure reading outside of valid range (high), and uncompensated voltage suspected to be below valid operating range for this function.
\$21	\$0001	Compensated pressure reading outside of valid range (low), and uncompensated voltage suspected to be under below operating range for this function.
\$20	Between \$0001 – \$01FE	Uncompensated voltage suspected to be below valid operating range for this function; The compensated reading is not guaranteed for accuracy.
\$00	Between \$0001 – \$01FE	Valid compensated pressure reading.

**3.2.8 UINT8 TPMS\_READ\_ACCELERATION\_X (UINT16 \*u16UUMA, UINT8 u8Avg, UINT8 u8FiltSelect, UINT8 u8DynamicOffset)**

- **Description:** Performs an uncompensated 10-bit measurement. While waiting for the ADC to converge, this function goes into STOP4. If the ADC, for an unexpected reason, fails to converge, this function has a built-in time-out: After five continuous non-ADC interrupts, the function will assume a failed ADC reading, flag it accordingly, and exit. If the LVWF (Low Voltage Warning Flag) hardware bit is set, it will flag it accordingly as well.
  - If the ADC value is over or under the normal operating condition, the "acceleration error" status flag will be set. The expected acceleration result will be forced to either "0" or "1023." (rail high or rail low).
  - If the ADC times out with no result, the "ADC error" status flag will be set.
- **Stack size:** 33 bytes
- **Approx. Duration:** 2869 μs (500-Hz filter, 1 reading), 4232 μs (250-Hz filter, 1 reading).
- **Power management:** This function requires the core to be configured for STOP4 mode and running at full bus speed.
- **Interrupt management:** This function utilizes the ADC interrupt to wake up from STOP mode.
- **Resources:** SMI, ADC, internal bond wires.

• **Input parameters:**

- UINT16 \*u16UUMA: Pointer to Universal Uncompensated Measurement Array (as described in [Section 2.3](#)). Only the 10-bit uncompensated acceleration result will be updated.
- UINT8 u8Avg: Number of measurements to average into one result. The value can be set to 1, 2, 4, 8, or 16.
- UINT8 u8FiltSelect: If non-zero, 250-Hz filter enabled. Otherwise, 500-Hz filter selected.
- UINT8 u8DynamicOffset: Selects the offset setting for the appropriate acceleration reading. Default is 6.

**Table 13. u8DynamicOffset valid values**

Offset Index	Offset when result of function is 256 counts assuming standard trim. Span does not change.
0	-70 g
1	-60 g
2	-50 g
3	-40 g
4	-30 g
5	-20 g
6	-10 g
7	0 g (default)
8	10 g
9	20 g
10	30 g
11	40 g
12	50 g
13	60 g
14	70 g
15	80 g

• **Returns:**

- UINT8 u8Status: Valid error flags/outputs are described in [Table 14](#).

**Table 14. Valid output conditions for TPMS\_READ\_ACCELERATION\_X**

u8Status Value	Measurement Value	Condition
\$04	\$03FF	Uncompensated acceleration reading outside of valid range (high).
\$04	\$0000	Uncompensated acceleration reading outside of valid range (low).
\$24	\$03FF	Uncompensated acceleration reading outside of valid range (high), and LVWF set.



u8Status Value	Measurement Value	Condition
\$24	\$0000	Uncompensated acceleration reading outside of valid range (low), and LVWF set.
\$80	\$0000	Uncompensated acceleration reading not acquired.
\$A0	\$0000	Uncompensated acceleration reading not acquired, and LVWF set.
\$00	Between \$0001 – \$03FE	Valid uncompensated acceleration reading.
\$20	Between \$0001 – \$03FE	Valid uncompensated acceleration reading, but LVWF set.

**3.2.9 UINT8 TPMS\_READ\_DYNAMIC\_ACCEL\_X (UINT8 u8Filter, UINT8\* u8Offset, UINT16\* u16UUMA)**

- **Description:** This function automatically executes a TPMS\_READ\_ACCELERATION\_X measurement with a given initial dynamic offset. If the result is too high or too low, it will change the dynamic offset value and re-execute TPMS\_READ\_ACCELERATION\_X until a) the result is valid or b) the result is railed high or low and there are no more offset steps. Offset and uncompensated acceleration inside the UUMA are updated.
- **Stack size:** 42 bytes
- **Approx. Duration:** 28687 µs from one extreme to the center; 2816 µs best case.
- **Power management:** This function requires the core to be configured for STOP4 mode and running at full bus speed.
- **Interrupt management:** This function utilizes the ADC interrupt to wake up from STOP mode.
- **Resources:** SMI, ADC, internal bond wires.
- **Input parameters:**
  - UINT8 u8FiltSelect: If non-zero, 250-Hz filter enabled. Otherwise, 500-Hz filter selected.
  - UINT8\* u8Offset: Pointer to initial offset level to load into SMI according to [Table 13](#). An updated offset value is returned at the end of the function.
  - UINT16\* Pointer to the Universal Uncompensated Measurement Array. Uncompensated acceleration will be updated accordingly.
- **Returns:**
  - UINT8 u8Status: Refer to TPMS\_READ\_ACCELERATION\_X for more information on the format of this status byte.

**3.2.10 UINT8 TPMS\_COMP\_ACCELERATION\_X (UINT16 \*u16CompAccelX, UINT16\* u16UUMA)**

- CR2032 Performs an 9-bit compensated acceleration measurement. It is the user's responsibility to ensure that updated and valid uncompensated voltage, temperature and acceleration readings are available in the UUMA for this routine to return a meaningful value.
  - If u16CompAccel rails low, u16CompAccel will be forced to 1 and the "over/underflow" status flag will be set.
  - If u16CompAccel rails high, u16CompAccel will be forced to \$1FE and the "over/underflow" status flag will be set.

- If the passed uncompensated voltage measurement is estimated to be under the guaranteed operational region, the routine will set the "Voltage" status flag. The accuracy of the returned value is not guaranteed.
- For repeatability data, refer to the FXTH87x06 data sheet.
- **Stack size:** 55 bytes
- **Approx. Duration:** 955  $\mu$ s
- **Power management:** This function executes entirely in RUN mode.
- **Interrupt management:** This function does not await interrupts. It is not affected by interrupts either.
- **Resources:** UUMA
- **Input parameters:**
  - UINT16 \*u16AccelX: Updated 9-bit compensated acceleration.
  - UINT16 \*u16UUMA: Pointer to Universal Uncompensated Measurement Array (as described in [Section 2.3](#)). Uncompensated voltage, temperature and X-axis acceleration will be taken from this array.
- **Returns:**
  - UINT8 u8Status: Valid error flags/outputs are described in [Table 15](#).

**Table 15. Valid output conditions for TPMS\_COMP\_ACCELERATION\_X**

u8Status Value	Measurement Value	Condition
\$01	\$01FE	Compensated acceleration reading outside of valid range (high).
\$01	\$0001	Compensated acceleration reading outside of valid range (low).
\$21	\$01FE	Compensated pressure reading outside of valid range (high), and uncompensated voltage suspected to be below valid operating range for this function.
\$21	\$0001	Compensated pressure reading outside of valid range (low), and uncompensated voltage suspected to be under below operating range for this function.
\$20	Between \$0001 – \$01FE	Uncompensated voltage suspected to be below valid operating range for this function; The compensated reading is not guaranteed for accuracy.
\$00	Between \$0001 – \$01FE	Valid compensated acceleration reading.

**3.2.11 UINT8 TPMS\_READ\_ACCELERATION\_Z (UINT16 \*u16UUMA, UINT8 u8Avg, UINT8 u8FiltSelect, UINT8 u8DynamicOffset)**

- **Description:** Performs an uncompensated 10-bit measurement. While waiting for the ADC to converge, this function goes into STOP4. If the ADC, for an unexpected reason, fails to converge, this function has a built-in time-out: After five continuous non-ADC interrupts, the function will assume a failed ADC reading, flag it accordingly, and exit. If the LVWF (Low Voltage Warning Flag) hardware bit is set, it will flag it accordingly as well.

- If the ADC value is over or under the normal operating condition, the "acceleration error" status flag will be set. The expected acceleration result will be forced to either "0" or "1023." (rail high or rail low).
- If the ADC times out with no result, the "ADC error" status flag will be set.
- **Stack size:** 33 bytes
- **Approx. Duration:** 2869 μs (500-Hz filter, 1 reading), 4232 μs (250-Hz filter, 1 reading).
- **Power management:** This function requires the core to be configured for STOP4 mode and running at full bus speed.
- **Interrupt management:** This function utilizes the ADC interrupt to wake up from STOP mode.
- **Resources:** SMI, ADC, internal bond wires.
- **Input parameters:**
  - UINT16 \*u16UUMA: Pointer to Universal Uncompensated Measurement Array (as described in [Section 2.3](#)). Only the 10-bit uncompensated acceleration result will be updated.
  - UINT8 u8Avg: Number of measurements to average into one result. The value can be set to 1, 2, 4, 8, or 16.
  - UINT8 u8FiltSelect: If non-zero, 250-Hz filter enabled. Otherwise, 500-Hz filter selected.
  - UINT8 u8DynamicOffset: Selects the offset setting for the appropriate acceleration reading. Default is 0.

**Table 16. u8DynamicOffset valid values**

Offset Index	Offset when result of function is 256 counts assuming standard trim. Span does not change.
0	–210 g
1	–180 g
2	–150 g
3	–120 g
4	–90 g
5	–60 g
6	–30 g
7	0 g (default)
8	30 g
9	60 g
10	90 g
11	120 g
12	150 g
13	180 g
14	210 g
15	240 g

- **Returns:**
  - UINT8 u8Status: Valid error flags/outputs are described in [Table 17](#).

Table 17. Valid output conditions for TPMS\_READ\_ACCELERATION\_Z

u8Status Value	Measurement Value	Condition
\$04	\$03FF	Uncompensated acceleration reading outside of valid range (high).
\$04	\$0000	Uncompensated acceleration reading outside of valid range (low).
\$24	\$03FF	Uncompensated acceleration reading outside of valid range (high), and LVWF set.
\$24	\$0000	Uncompensated acceleration reading outside of valid range (low), and LVWF set.
\$80	\$0000	Uncompensated acceleration reading not acquired.
\$A0	\$0000	Uncompensated acceleration reading not acquired, and LVWF set.
\$00	Between \$0001 – \$03FE	Valid uncompensated acceleration reading.
\$20	Between \$0001 – \$03FE	Valid uncompensated acceleration reading, but LVWF set

### 3.2.12 UINT8 TPMS\_READ\_DYNAMIC\_ACCEL\_Z (UINT8 u8Filter, UINT8\* u8Offset, UINT16\* u16UUMA)

- **Description:** This function automatically executes a TPMS\_READ\_ACCELERATION\_Z measurement with a given initial dynamic offset. If the result is too high or too low, it will change the dynamic offset value and re-execute TPMS\_READ\_ACCELERATION\_Z until a) the result is valid or b) the result is railed high or low and there are no more offset steps. Offset and uncompensated acceleration inside the UUMA are updated.
- **Stack size:** 42 bytes
- **Approx. Duration:** 28687  $\mu$ s from one extreme to the center; 2816  $\mu$ s best case.
- **Power management:** This function requires the core to be configured for STOP4 mode and running at full bus speed.
- **Interrupt management:** This function utilizes the ADC interrupt to wake up from STOP mode.
- **Resources:** SMI, ADC, internal bond wires.
- **Input parameters:**
  - UINT8 u8FiltSelect: If non-zero, 250-Hz filter enabled. Otherwise, 500-Hz filter selected.
  - UINT8\* u8Offset: Pointer to initial offset level to load into SMI according to [Table 13](#). An updated offset value is returned at the end of the function.
  - UINT16\* Pointer to the Universal Uncompensated Measurement Array. Uncompensated acceleration will be updated accordingly.
- **Returns:**
  - UINT8 u8Status: Refer to TPMS\_READ\_ACCELERATION\_Z for more information on the format of this status byte.

**3.2.13 UINT8 TPMS\_COMP\_ACCELERATION\_Z (UINT16 \*u16CompAccel, UINT16\* u16UUMA)**

- **Description:** Performs an 9-bit compensated acceleration measurement. It is the user's responsibility to ensure that updated and valid uncompensated voltage, temperature and acceleration readings are available in the UUMA for this routine to return a meaningful value.
  - If u16CompAccel rails low, u16CompAccel will be forced to 1 and the "over/underflow" status flag will be set.
  - If u16CompAccel rails high, u16CompAccel will be forced to \$1FE and the "over/underflow" status flag will be set.
  - If the passed uncompensated voltage measurement is estimated to be under the guaranteed operational region, the routine will set the "Voltage" status flag. The accuracy of the returned value is not guaranteed.
  - For repeatability data, refer to the FXTH87x06 data sheet.
- **Stack size:** 55 bytes
- **Approx. Duration:** 955 μs
- **Power management:** This function executes entirely in RUN mode.
- **Interrupt management:** This function does not await interrupts. It is not affected by interrupts either.
- **Resources:** UUMA
- **Input parameters:**
  - UUINT16 \*u16Accel: Updated 9-bit compensated acceleration.
  - UUINT16 \*u16UUMA: Pointer to Universal Uncompensated Measurement Array (as described in [Section 2.3](#)). Uncompensated voltage, temperature and acceleration will be taken from this array.
- **Returns:**
  - UUINT8 u8Status: Valid error flags/outputs are described in [Table 18](#).

**Table 18. Valid output conditions for TPMS\_COMP\_ACCELERATION\_Z**

u8Status Value	Measurement Value	Condition
\$01	\$01FE	Compensated acceleration reading outside of valid range (high).
\$01	\$0001	Compensated acceleration reading outside of valid range (low).
\$21	\$01FE	Compensated pressure reading outside of valid range (high), and uncompensated voltage suspected to be below valid operating range for this function.
\$21	\$0001	Compensated pressure reading outside of valid range (low), and uncompensated voltage suspected to be under below operating range for this function.
\$20	Between \$0001 – \$01FE	Uncompensated voltage suspected to be below valid operating range for this function; The compensated reading is not guaranteed for accuracy.
\$00	Between \$0001 – \$01FE	Valid compensated acceleration reading.

**3.2.14 UINT8 TPMS\_READ\_ACCELERATION\_XZ (UINT16 \*u16UUMA, UINT8 u8Avg, UINT8 u8FiltSelect, UINT8 u8DynamicOffsetX, UINT8 u8DynamicOffsetZ)**

- **Description:** Performs an uncompensated 10-bit measurement. While waiting for the ADC to converge, this function goes into STOP4. If the ADC, for an unexpected reason, fails to converge, this function has a built-in time-out: After five continuous non-ADC interrupts, the function will assume a failed ADC reading, flag it accordingly, and exit.
  - If the ADC value is over or under the normal operating condition, the "acceleration error" status flag will be set. The expected acceleration result will be forced to either "0" or "1023." (rail high or rail low).
  - If the ADC times out with no result, the "ADC error" status flag will be set.
- **Stack size:** 34 bytes
- **Approx. Duration:** 5690 μs (500-Hz filter, 1 reading), 8440 μs (250-Hz filter, 1 reading).
- **Power management:** This function requires the core to be configured for STOP4 mode and running at full bus speed.
- **Interrupt management:** This function utilizes the ADC interrupt to wake up from STOP mode.
- **Resources:** SMI, ADC, internal bond wires.
- **Input parameters:**
  - **UINT16 \*u16UUMA:** Pointer to Universal Uncompensated Measurement Array (as described in [Section 2.3](#)). Only the 10-bit uncompensated acceleration result will be updated.
  - **UINT8 u8Avg:** Number of measurements to average into one result. The value can only be set to 1.
  - **UINT8 u8FiltSelect:** If non-zero, 250-Hz filter enabled. Otherwise, 500-Hz filter selected.
  - **UINT8 u8DynamicOffsetX:** Selects the offset setting for the appropriate acceleration reading. Refer to [Table 13](#) for more information.
  - **UINT8 u8DynamicOffsetZ:** Selects the offset setting for the appropriate acceleration reading. Refer to [Table 16](#) for more information.
- **Returns:**
  - **UINT8 u8Status:** Valid error flags/outputs are described in [Table 19](#).

**Table 19. Valid output conditions for TPMS\_READ\_ACCELERATION\_XZ**

u8Status Value	Measurement Value	Condition
\$04	\$03FF	Uncompensated X and/or Z acceleration reading outside of valid range (high).
\$04	\$0000	Uncompensated X and/or Z acceleration reading outside of valid range (low).
\$24	\$03FF	Uncompensated X and/or Z acceleration reading outside of valid range (high), and LVWF set.
\$24	\$0000	Uncompensated X and/or Z acceleration reading outside of valid range (low), and LVWF set.
\$80	Undefined	Uncompensated acceleration reading not acquired.

u8Status Value	Measurement Value	Condition
\$A0	Undefined	Uncompensated acceleration reading not acquired, and LVWF set.
\$00	Between \$0001 – \$03FE	Valid uncompensated acceleration reading.
\$20	Between \$0001 – \$03FE	Valid uncompensated acceleration reading, but LVWF set.

### 3.2.15 UINT8 TPMS\_READ\_DYNAMIC\_ACCEL\_XZ (UINT8 u8Filter, UINT8\* u8OffsetX, UINT8\* u8OffsetZ, UINT16\* u16UUMA)

- **Description:** This function automatically executes a TPMS\_READ\_DYNAMIC\_ACCEL\_X measurement, followed by a TPMS\_READ\_DYNAMIC\_ACCEL\_Z measurement with given initial dynamic offsets. Refer to the description of these functions for more information.
- **Stack size:** 54 bytes
- **Approx. Duration:** 50240 µs from one extreme to the center; 8200 µs best case.
- **Power management:** This function requires the core to be configured for STOP4 mode and running at full bus speed.
- **Interrupt management:** This function utilizes the ADC interrupt to wake up from STOP mode.
- **Resources:** SMI, ADC, internal bond wires.
- **Input parameters:**
  - UINT8 u8FiltSelect: If non-zero, 250-Hz filter enabled. Otherwise, 500-Hz filter selected.
  - UINT8\* u8OffsetX: Pointer to initial offset level to load into SMI according to [Table 13](#). An updated offset value is returned at the end of the function.
  - UINT8\* u8OffsetZ: Pointer to initial offset level to load into SMI according to [Table 16](#). An updated offset value is returned at the end of the function.
  - UINT16\* Pointer to the Universal Uncompensated Measurement Array. Uncompensated acceleration for both axes will be updated accordingly.
- **Returns:**
  - UINT8 u8Status: Refer to TPMS\_READ\_ACCELERATION\_Z for more information on the format of this status byte.

### 3.2.16 UINT8 TPMS\_COMP\_ACCELERATION\_XZ (UINT16 \*u16CompAccel, UINT16\* u16UUMA)

- **Description:** This function internally calls TPMS\_COMP\_ACCELERATION\_X followed by TPMS\_COMP\_ACCELERATION\_Z. It places the compensated results in a 2-word array. For more information, refer to the functions afore mentioned.
- **Stack size:** 60 bytes
- **Approx. Duration:** 1910 µs
- **Power management:** This function executes entirely in RUN mode.
- **Interrupt management:** This function does not await interrupts. It is not affected by interrupts either.
- **Resources:** UUMA
- **Input parameters:**

- UINT16 \*u16CompAccel: Updated 9-bit compensated X-axis acceleration followed by Z-axis acceleration.
- UINT16 \*u16UUMA: Pointer to Universal Uncompensated Measurement Array (as described in [Section 2.3](#)). Uncompensated voltage, temperature and acceleration will be taken from this array.
- **Returns:**
  - UINT8 u8Status: Valid error flags/outputs are described in [Table 20](#).

**Table 20. Valid output conditions for TPMS\_COMP\_ACCELERATION\_XZ**

u8Status Value	Measurement Value	Condition
\$01	\$01FE	Compensated acceleration reading outside of valid range (high).
\$01	\$0001	Compensated acceleration reading outside of valid range (low).
\$21	\$01FE	Compensated pressure reading outside of valid range (high), and uncompensated voltage suspected to be below valid operating range for this function.
\$21	\$0001	Compensated pressure reading outside of valid range (low), and uncompensated voltage suspected to be under below operating range for this function.
\$20	Between \$0001 – \$01FE	Uncompensated voltage suspected to be below valid operating range for this function; The compensated reading is not guaranteed for accuracy.
\$00	Between \$0001 – \$01FE	Valid compensated acceleration reading.

**3.2.17 UINT8 TPMS\_READ\_V0 (UINT16 \*u16Result, UINT8 u8Avg)**

- **Description:** Performs an 10-bit uncompensated measurement at pin PTA0.
- **Stack size:** 24 bytes
- **Approx. Duration:** 107 μs
- **Power management:** This function requires the core to be configured for STOP4 mode and running at full bus speed.
- **Interrupt management:** This function utilizes the ADC interrupt to wake up from STOP mode.
- **Resources:** ADC, PTA0.
- **Input parameters:**
  - UINT16 \*u16Result: Updated 10-bit uncompensated measurement.
  - UINT8 u8Avg: Number of measurements to average into one result. The value can be set to 1, 2, 4, 8, or 16.
- **Returns:**
  - UINT8 u8Status: Valid error flags/outputs are described in [Table 21](#).



**Table 21. Valid output conditions for TPMS\_READ\_V0 and TPMS\_READ\_V1**

u8Status Value	Measurement Value	Condition
\$01	\$0000	Reading not acquired.
\$00	Between \$0000 – \$03FE	Valid reading.

**3.2.18 UINT8 TPMS\_READ\_V1 (UINT16 \*u16Result, UINT8 u8Avg)**

- **Description:** Performs an 10-bit uncompensated measurement at pin PTA1.
- **Stack size:** 24 bytes
- **Approx. Duration:** 107 μs
- **Power management:** This function requires the core to be configured for STOP4 mode and running at full bus speed.
- **Interrupt management:** This function utilizes the ADC interrupt to wake up from STOP mode.
- **Resources:** ADC, PTA1
- **Input parameters:**
  - UINT16 \*u16Result: Updated 10-bit uncompensated measurement.
  - UINT8 u8Avg: Number of measurements to average into one result. The value can be set to 1, 2, 4, 8, or 16.
- **Returns:**
  - UINT8 u8Status: Valid error flags/outputs are described in [Table 21](#).

**3.2.19 UINT8 TPMS\_LFOCAL (void)**

- **Description:** Performs PWU clock calibration. The wake up and periodic reset time can be calibrated more accurately by using the TPMS\_LFOCAL firmware subroutine. This subroutine turns on the RFM crystal oscillator and feeds a 500 kHz clock via the DX signal to the TPM1 for one cycle of the LFO. The measured time is used to calculate the correct value for the WDIV0:5-bits for a WCLK period of 1 second. The resulting value for use in the WDIV0:5-bits is returned in the accumulator. The user can decide whether to load the value to the WDIV0:5-bits or store for future reference. The TPMS\_LFOCAL subroutine cannot be used while the RFM is transmitting or the TPM1 is being used for another task. This routine will also consume more power due to the crystal oscillator running. This function accesses and writes data to the SIMOPT2 register. Since some of the bits in this register are write-once-only, it should be configured prior to calling this routine.
- **Stack size:** 9 bytes
- **Approx. Duration:** 1218 μs
- **Power management:** This function executes entirely in RUN mode. It requires the MCU to be configured for 4-MHz bus clock, and the RFM to be enabled but not transmitting prior to making the call.
- **Interrupt management:** This function does not await any interrupts. It WILL be affected by interrupts.
- **Resources:** TPM, SIMOPT2, RFM
- **Input parameters:**
  - None
- **Returns:**
  - UINT8 u8WDIV: WDIV compensated value.

**Warning:** This routine writes to write-once register SIMOPT2. Any configuration involving this register must be performed before calling this routine. Prior to calling this routine, the RFM must be enabled.

### 3.2.20 UINT8 TPMS\_MFOCAL (void)

- **Description:** Performs MFO cross-check verification. This function will measure the bus clock relative to Dx, but first executes a test to verify the presence of the external XTAL. When error is zero, it returns "128." Any deviation from this value should be considered an error. This result can then be used to estimate the error in the RFBT setting. The TPMS\_MFOCAL subroutine cannot be used while the RFM is transmitting or the TPM1 is being used for another task. This function accesses and writes data to the SIMOPT2 register. Since some of the bits in this register are write-once-only, it should be configured prior to calling this routine.
- **Stack size:** 36 bytes
- **Approx. Duration:** 2352  $\mu$ s
- **Power management:** This function executes entirely in RUN mode. It requires the MCU to be configured for 4-MHz bus clock, and the RFM to be enabled but not transmitting prior to making the call.
- **Interrupt management:** This function does not await any interrupts. It WILL be affected by interrupts.
- **Resources:** TPM, SIMOPT2, RFM
- **Input parameters:**
  - None
- **Returns:**
  - UINT8 u8Error: Percentage of error away from target frequency (4 MHz).

**Note:** This function is not correctly implemented so returns incorrect data.

**Warning:** This routine writes to write-once register SIMOPT2. Any configuration involving this register must be performed before calling this routine. This function is not correctly implemented meaning that it exists and can be executed by the user, but it will not return the expected data described above. The data returned will be incorrect so must not be used by the application. This implies the user should avoid using this function.

### 3.2.21 void TPMS\_RF\_ENABLE (UINT8 u8Switch)

- **Description:** This function enables or disables the RF module in the FXTH87xx22 and transfers adequate PLL trim data to the module. It should be called prior to any other RF operation.
- **Stack size:** 4 bytes
- **Approx. Duration:** 378  $\mu$ s
- **Power management:** This function executes entirely in RUN mode.
- **Interrupt management:** This function does not await any interrupts. It will be affected by interrupts.
- **Resources:** SIMOPT1, RFM
- **Input parameters:**
  - UINT8 u8Switch: Enable (non-zero) or disable (zero) RFM.
- **Returns:**
  - void.

**Warning:** This routine writes to write-once register SIMOPT2. Any configuration involving this register must be performed before calling this routine.

### 3.2.22 void TPMS\_RF\_RESET (void)

- **Description:** This function sends a master reset to the RFM and reloads PLL trim values into the module. It requires the RFM to have been enabled previously.
- **Stack size:** 3 bytes
- **Approx. Duration:** 228  $\mu$ s
- **Power management:** This function executes entirely in RUN mode.
- **Interrupt management:** This function does not await any interrupts. It will not be affected by interrupts.
- **Resources:** RFM
- **Input parameters:**
  - None
- **Returns:**
  - void

### 3.2.23 void TPMS\_RF\_READ\_DATA (UINT8 u8Size, UINT8 \*u8RAMBuffer, UINT8 u8RFMBuffer)

- **Description:** This function reads several consecutive bytes from the dedicated RFM buffer registers and copies them to a given address in RAM. It assumes that BUFF0 is location "0". The data is transferred from the LSB bit of the RFM data registers to the LSB of the target memory address (standard data bit order). This function manages the RFM's buffer paged memory.
  - In case the required buffer address is out of bounds, the routine will return "0" for that location.
- **Stack size:** 11 bytes
- **Approx. Duration:** 207  $\mu$ s (for 8 bytes, switching pages included).
- **Power management:** This function executes entirely in RUN mode.
- **Interrupt management:** This function does not await any interrupts. It will not be affected by interrupts.
- **Resources:** RFM
- **Input parameters:**
  - UINT8 u8Size: Number of bytes to read.
  - UINT8 \*u8RamBuffer: Target memory location.
  - UINT8 u8RFMBuffer: Buffer register (0 to 31) to read.
- **Returns:**
  - void

### 3.2.24 void TPMS\_RF\_READ\_DATA\_REVERSE (UINT8 u8Size, UINT8 \*u8RAMBuffer, UINT8 u8RFMBuffer)

- **Description:** This function reads several consecutive bytes from the dedicated RFM buffer registers and copies them to a given address in RAM. It assumes that BUFF0 is location "0". The data is transferred from the LSB bit of each byte of the RFM data registers to the MSB of each of the bytes of the target memory address (reversed data bit order). This function manages the RFM's buffer paged memory.

- In case the required buffer address is out of bounds, the routine will return "0" for that location.
- **Stack size:** 12 bytes
- **Approx. Duration:** 257  $\mu$ s (for 8 bytes, switching pages included).
- **Power management:** This function executes entirely in RUN mode.
- **Interrupt management:** This function does not await any interrupts. It will not be affected by interrupts.
- **Resources:** RFM
- **Input parameters:**
  - UINT8 u8Size: Number of bytes to read.
  - UINT8 \*u8RamBuffer: Target memory location.
  - UINT8 u8RFMBuffer: Buffer register (0 to 31) to read.
- **Returns:**
  - void

### 3.2.25 void TPMS\_RF\_WRITE\_DATA (UINT8 u8Size, UINT8 \*u8RAMBuffer, UINT8 u8RFMBuffer)

- **Description:** This function copies several consecutive bytes from RAM into the dedicated RFM Output Buffer. It assumes that BUFF0 is location "0". The data is transferred from the LSB bit of RAM to the LSB of the RFM data register (standard data bit order). This function manages the RFM's buffer paged-memory.
  - In case the destination buffer address is out of bounds, the register value will not be written.
- **Stack size:** 10 bytes
- **Approx. Duration:** 195  $\mu$ s (for 8 bytes, switching pages included).
- **Power management:** This function executes entirely in RUN mode.
- **Interrupt management:** This function does not await any interrupts. It will not be affected by interrupts.
- **Resources:** RFM
- **Input parameters:**
  - UINT8 u8Size: Number of bytes to write.
  - UINT8 \*u8RamBuffer: Source memory location.
  - UINT8 u8RFMBuffer: Starting buffer register (0 to 31) to write.
- **Returns:**
  - void

### 3.2.26 void TPMS\_RF\_WRITE\_DATA\_REVERSE (UINT8 u8Size, UINT8 \*u8RAMBuffer, UINT8 u8RFMBuffer)

- **Description:** This function copies several consecutive bytes from RAM into the dedicated RFM Output Buffer. It assumes that BUFF0 is location "0". The data is transferred from the LSB bit of each byte in RAM to the MSB of each byte in the RFM data register (reversed data bit order). This function manages the RFM's buffer paged-memory.
  - In case the destination buffer address is out of bounds, the register value will not be written.
- **Stack size:** 11 bytes
- **Approx. Duration:** 256  $\mu$ s (for 8 bytes, switching pages included).

- **Power management:** This function executes entirely in RUN mode.
- **Interrupt management:** This function does not await any interrupts. It will not be affected by interrupts.
- **Resources:** RFM
- **Input parameters:**
  - UINT8 u8Size: Number of bytes to write.
  - UINT8 \*u8RamBuffer: Source memory location.
  - UINT8 8uRFMBuffer: Starting buffer register (0 to 31) to write.
- **Returns:**
  - void

**3.2.27 void TPMS\_RF\_CONFIG\_DATA (UINT16 \*u16RFParam)**

- **Description:** This function is included for backward compatibility with the MPXY8300. This function configures the RFM for transmission. It does not configure inter-frame wait times, which must be configured manually.
- **Stack size:** 4 bytes
- **Approx. Duration:** 32 μs
- **Power management:** This function executes entirely in RUN mode.
- **Interrupt management:** This function does not await any interrupts. It will not be affected by interrupts.
- **Resources:** RFM
- **Input parameters:**
  - UINT16\* u16RFParam Format as described in [Table 22](#).

**Table 22. u16RFParam Array format**

Index	Description
0	Refer to <a href="#">Table 23</a> for description.
1	PLLA value.
2	PLLB value.

**Table 23. Description of Element 0 in the u16RFParam Array**

Bits	Description
15:8	Prescaler value. Described in data sheet as RFCR0.
7	End Of Message- If '1', EOM is set, if '0', it's not set.
6	Polarity Bit - If '1', polarity is inverted, If '0', it is non-inverted.
5:4	Not used.
2:3	Encoding value
1	Frequency selection - If '1', RFM is configured for 434 MHz, if '0', it is configured for 315 MHz.
0	Modulation - If '1', RFM is configured for FSK, if '0' it is configured for OOK.

- **Returns:**
  - void

**3.2.28 void TPMS\_RF\_SET\_TX (UINT8 u8BufferSize)**

- **Description:** This function allows the RFM to transmit data previously loaded in the buffer. It should be called after the RF module has been enabled and configured.
- **Stack size:** 3 bytes
- **Approx. Duration:** 12  $\mu$ s
- **Power management:** This function executes entirely in RUN mode.
- **Interrupt management:** This function does not await any interrupts. It will not be affected by interrupts.
- **Resources:** RFM
- **Input parameters:**
  - UINT8 u8BufferSize: Number of bits in the buffer -1 (i.e., to transmit one bit, u8BufferSize should equal 0).
- **Returns:**
  - void

**3.2.29 void TPMS\_RF\_DYNAMIC\_POWER (UINT8 u8CompT, UINT8 u8CompV, UINT8\* pu8PowerManagement)**

- **Description:** Depending on the passed parameters, this function can:
  - Force the RF power setting (RFCFR2\_PWR) to a passed value (when BIT5 of u8PowerManagement is clear)
  - When BIT5 of u8PowerManagement is set, find the best RF power setting (RFCFR2\_PWR) dynamically based on voltage, temperature, and current carrier frequency in order to target 3 dBm as actual output power. This value of 3 dBm can be increased or decreased in given temperature ranges using the offsets (0.5 dBm/count) in the pu8PowerManagement array.
  - Similar to the case above, the user can specify a target power region with an offset.
- **Stack size:** 11 bytes
- **Approx. Duration:** 60  $\mu$ s when calculating dynamic power; 19.2 when power setting is passed.
- **Power management:** This function executes entirely in RUN mode.
- **Interrupt management:** This function does not await any interrupts. It will not be affected by interrupts.
- **Resources:** RFM
- **Input parameters:**
  - UINT8 u8CompT: Compensated temperature reading.
  - UINT8 u8CompV: Compensated voltage reading.
  - UINT8\* pu8PowerManagement: This is a pointer to an array of eight elements as described in [Table 24](#):

**Table 24. \*pu8PowerManagement format**

Index Value	Description
pu8PowerManagement[0]	Dynamic Compensation switch as described in <a href="#">Table 25</a> .
pu8PowerManagement[1]	Offset step for temperatures $\geq 92$ °C
pu8PowerManagement[2]	Offset step for $60$ °C $\leq$ temp $< 92$ °C
pu8PowerManagement[3]	Offset step for $43$ °C $\leq$ temp $< 60$ °C
pu8PowerManagement[4]	Offset step for $25$ °C $\leq$ temp $< 43$ °C

Index Value	Description
pu8PowerManagement[5]	Offset step for $1\text{ °C} \leq \text{temp} < 25\text{ °C}$
pu8PowerManagement[6]	Offset step for $-20\text{ °C} \leq \text{temp} < 1\text{ °C}$
pu8PowerManagement[7]	Offset step for $-40\text{ °C} \leq \text{temp} < -20\text{ °C}$

Table 25. pu8PowerManagement[0] format

BIT	Description
MSB	Not used.
BIT6	Not used.
BIT5	Dynamic compensation enable. If set, the function will decide what the optimal power setting is based on voltage and temperature; In this case, values stored in the array will be added to the found target. If clear, BIT4:0 will be used to set the power level directly.
BIT4:0	When BIT5 is clear, the value passed here will be used to set the RF power step directly.

- **Returns:**
  - void

**Warning:** The RF Module must be turned on prior to calling this routine.

### 3.2.30 void TPMS\_MSG\_INIT (void)

- **Description:** This function is to be called before using any MSG routine. It initializes PTA1 and PTA0 to their correct initial state for a simulated SPI.
- **Stack size:** 2 bytes
- **Approx. Duration:** 4  $\mu\text{s}$
- **Power management:** This function executes entirely in RUN mode.
- **Interrupt management:** This function does not await any interrupts. It will not be affected by interrupts.
- **Resources:** Pins PTA1 and PTA0.
- **Input parameters:**
  - None
- **Returns:**
  - void

### 3.2.31 UINT8 TPMS\_MSG\_READ (void)

- **Description:** This function is in charge to read any incoming message at a network level via an emulated serial interface on PTA1 and PTA0. As the master, the FXTH87xx22 manages the clock on PTA1. On falling edge of the clock, the module reads a new data bit on PTA0 (programmed as input), MSB first.
- **Stack size:** 2 bytes
- **Approx. Duration:** 80  $\mu\text{s}$
- **Power management:** This function executes entirely in RUN mode.

- **Interrupt management:** This function does not await any interrupts. It will not be affected by interrupts.
- **Resources:** Pins PTA1 and PTA0.
- **Input parameters:**
  - None
- **Returns:**
  - UINT8 u8ReadByte: Incoming byte from the emulated serial interface.

### 3.2.32 UINT8 TPMS\_MSG\_WRITE (UINT8 u8SendByte)

- **Description:** This function is in charge to write a message at a network level via an emulated serial interface on PTA1 and PTA0. As the master, the FXTH87xx22 manages the clock on PTA1. On rising edge of the clock, the module puts down a new data bit on PTA0 (programmed as output), MSB first.
- **Stack size:** 2 bytes
- **Approx. Duration:** 80  $\mu$ s
- **Power management:** This function executes entirely in RUN mode.
- **Interrupt management:** This function does not await any interrupts. It will not be affected by interrupts.
- **Resources:** Pins PTA1 and PTA0.
- **Input parameters:**
  - UINT8 u8SendByte: Byte to be outputted through the emulated serial interface.
- **Returns:**
  - UINT8 u8ReadByte: Incoming byte from the emulated serial interface.

### 3.2.33 UINT8 TPMS\_CHECKSUM\_XOR (UINT8 \*u8Buffer, UINT8 u8Size, UINT8 u8Checksum)

- **Description:** Calculates a checksum for the given buffer based on XOR operations.
- **Stack size:** 8 bytes
- **Approx. Duration:** 113  $\mu$ s for 8 bytes of data.
- **Power management:** This function executes entirely in RUN mode.
- **Interrupt management:** This function does not await any interrupts. It will not be affected by interrupts.
- **Resources:** N/A
- **Input parameters:**
  - UINT8 \*u8Buffer: Buffer where data is located.
  - UINT8 u8Size: Size of buffer (in bytes).
  - UINT8 u8Checksum: Previous checksum. This argument is useful when the function is used recursively. It must equal "0" if there is no previous data.
- **Returns:**
  - UINT8 u8NewChecksum: New calculated checksum.

### 3.2.34 UINT8 TPMS\_CRC8 (UINT8 \*u8Buffer, UINT16 u16SizeInBytes, UINT8 u8Remainder)

- **Description:** Calculates a CRC8 on a portion of the designated area using polynomial  $x^8 + x^5 + x^3 + x^2 + x + 1$ .
- **Stack size:** 9 bytes



- **Approx. Duration:** 240 µs for 8 bytes of data.
- **Power management:** This function executes entirely in RUN mode.
- **Interrupt management:** This function does not await any interrupts. It will not be affected by interrupts.
- **Resources:** N/A
- **Input parameters:**
  - UINT8 \*u8Buffer: Buffer where data is located.
  - UINT16 u16SizeInBytes: Size of the designated buffer (in bytes).
  - UINT8 u8Remainder: Initial remainder. This argument is useful when the function is used recursively. It must equal "0" if there is no previous data.
- **Returns:**
  - UINT8 u8NewCRC: New calculated CRC8.

### 3.2.35 UINT16 TPMS\_CRC16 (UINT8 \*u8Buffer, UINT16 u16MByteSize, UINT16 u16Remainder)

- **Description:** Calculates a CRC16 on a portion of the designated memory area by using a look-up table. Polynomial used is \$1021 (standard for CRC16-CCITT).
- **Stack size:** 12 bytes
- **Approx. Duration:** 236 µs for 8 bytes.
- **Power management:** This function executes entirely in RUN mode.
- **Interrupt management:** This function does not await any interrupts. It will not be affected by interrupts.
- **Resources:** N/A
- **Input parameters:**
  - UINT8 \*u8Buffer: Buffer where data is located.
  - UINT16 u16MByteSize: Size of the designated buffer (in bytes).
  - UINT16 u16Remainder: Initial remainder.
- **Returns:**
  - UINT16 u16NewCRC: New calculated CRC16.

**Note:** This function is not correctly implemented so returns incorrect data.

**Warning:** This function is not correctly implemented meaning that it exists and can be executed by the user, but it will not return the expected data described above. The data returned will be incorrect so must not be used by the application. This implies the user should avoid using this function.

### 3.2.36 UINT16 TPMS\_SQUARE\_ROOT (UINT16 u16Process)

- **Description:** Calculates a two-digit remainder of (square root \* 10) using a fast algorithm.
- **Stack size:** 49 bytes
- **Approx. Duration:** 365 µs
- **Power management:** This function executes entirely in RUN mode.
- **Interrupt management:** This function does not await any interrupts. It will not be affected by interrupts.
- **Resources:** N/A
- **Input parameters:**
  - UINT16 u16Process: The number from which to get the square root from.
- **Returns:**

- UINT16 Root of the number \* 10.

**3.2.37 void TPMS\_READ\_ID (UINT8 \*u8Code, UINT8 u8Offset)**

- **Description:** Copies the device's UniqueID and firmware version stored in firmware flash to RAM.
- **Stack size:** 10 bytes
- **Approx. Duration:** 119 μs
- **Power management:** This function executes entirely in RUN mode.
- **Interrupt management:** This function does not await any interrupts. It will not be affected by interrupts.
- **Resources:** N/A
- **Input parameters:**
  - UINT8 \*u8Code: RAM location where data will be copied. [Table 26](#) describes the format of the 6 bytes returned.

**Table 26. u8Code format**

Index	Description
0	Firmware version.
1	Derivative descriptor.
2:5	32-bit UniqueID.

- UINT8 u8Offset: Index of the first value to return. The use of this argument allows the user to skip firmware version, derivative description, or upper bytes of the UniqueID.
- **Returns:**
  - void

**3.2.38 void TPMS\_LF\_ENABLE (UINT8 u8Switch)**

- **Description:** The function first configures the LFR registers as recommended by NXP and described in [Section 2.6](#) of this document. Then the LFR module is enabled or disabled.
- **Stack size:** 5 bytes
- **Approx. Duration:** 32 μs
- **Power management:** This function executes entirely in RUN mode.
- **Interrupt management:** This function does not await any interrupts. It will not be affected by interrupts.
- **Resources:** LFR
- **Input parameters:**
  - UINT8 u8Switch: Enable (non-zero) or disable (zero) LFR.
- **Returns:**
  - void

**3.2.39 UINT8 TPMS\_LF\_READ\_DATA (UINT8 \*u8Buffer, UINT8 u8Count)**

- **Description:** Once the user has configured and enabled the LFR, it is customary to go into a low-power state mode and wait for a datagram. After the first byte of an incoming datagram is successfully received, this function should be called immediately; It will receive the complete datagram and place it in RAM. Be careful to call the function

upon reception of the first data byte (LFDRF flag) and not upon detection of the ID (LFIDF flag) in case the LFIDIE is enabled. This function assumes that the LFR module is configured accordingly for a Manchester reception; that the module's interrupts are enabled; and that the first byte has already been received and is waiting in the LFR received buffer. While waiting for the next byte, this function goes into STOP4. If the byte, for an unexpected reason, is not received, this function has a built-in timeout: After five continuous non-LFR interrupts, the function will assume a failed LFR reception and exit. In order to leave the routine as soon as possible after reception of all the data bytes it is recommended to enable the LF error interrupt (LFRERIE). In summary, the two necessary interrupts to be enabled are LFDRIE and LFRERIE.

- **Stack size:** 7 bytes
- **Approx. Duration:** Data dependant; ~2 msec per byte.
- **Power management:** This function requires the core to be configured for STOP4 mode and running at full bus speed.
- **Interrupt management:** This function utilizes the LFR interrupt to wake up from STOP mode. It does not await any other interrupts and should not be affected by them.
- **Resources:** LFR
- **Input parameters:**
  - UINT8 \*u8Buffer: RAM Buffer where data will be placed.
  - UINT8 u8Count: Number of bytes expected.
- **Returns:**
  - UINT8 u8BytesReceived: Actual number of bytes received.

**Warning:** This function requires ~24  $\mu$ s from the moment it is called to the moment the first byte is copied into the RAM buffer. The user must consider this time when designing their firmware.

### 3.2.40 UINT8 TPMS\_WIRE\_AND\_ADC\_CHECK (UINT8 u8TestMask)

- **Description:** This function checks if there is any bonding wire failure between the embedded core and the P-cell; or between the core and the g-cell. It also performs an optional ADC test. This latter test consists on taking two reference measurements (ground and Vdd) using internal channels and comparing them with the expected results. When configuring for a P-cell or g-cell wire check, Interrupts must be enabled before calling this routine. In case of no issues found, "0" will be returned, else it sets status flags as follows:
  - On P-cell error, sets "BONDERR" and "pressure error" flags.
  - On g-cell error, sets the "BONDERR" and "acceleration error" flags.
  - On ADC error, sets the "ADCERR" flag.
- **Stack size:** 44 bytes
- **Approx. Duration:** 29600  $\mu$ s for all tests; 102  $\mu$ s for ADC only; about 9800  $\mu$ s for each sensor test.
- **Power management:** This function requires the core to be configured for STOP4 mode and running at full bus speed.
- **Interrupt management:** This function utilizes the ADC interrupt to wake up from STOP mode.
- **Resources:** ADC, SMI, internal bond wires.
- **Input parameters:**
  - UINT8 u8TestMask: This variable determines what checks are performed as described by [Table 27](#).

Table 27. u8TestMask format

u8TestMask Bit	Description
BIT0:1	Reserved.
BIT2	If set, P-cell bond-wire check performed.
BIT3	If set, X-axis bond-wire check performed.
BIT4	If set, Z-axis bond-wire check performed.
BIT5:6	Reserved.
BIT7	If set, ADC check performed.

- **Returns:**
  - UINT8 u8Status: Status flags as described in [Table 28](#).

Table 28. u8Status valid values for TPMS\_WIRE\_AND\_ADC\_CHECK

u8TestMask Bit	Description
BIT0:1	Always clear.
BIT2	If set, P-cell bond-wire error detected.
BIT3	Always clear.
BIT4	If set, g-cell bond-wire error detected.
BIT5:6	Always clear.
BIT7	If set, ADC error detected.

**Warning:** This routine is known to be inexact. Avoid its use if possible.

### 3.2.41 void TPMS\_FLASH\_WRITE (UINT16 u16Address, UINT8\* u8Buffer, UINT8 u8Size)

- **Description:** This function writes consecutive bytes from a given address in memory to a specified location in FLASH.
- **Stack size:** 15 bytes
- **Approx. Duration:** 1336  $\mu$ s for 8 bytes of data.
- **Power management:** This function executes entirely in RUN mode.
- **Interrupt management:** This function does not await any interrupts. It will be affected by interrupts.
- **Resources:** Global RAM locations \$0090 – \$00CA.
- **Input parameters:**
  - UINT16 u16Address: Flash starting address.
  - UINT8 \*u8Buffer: Source memory address.
  - UINT8 u8Size: Number of data bytes to be written.
- **Returns:**
  - void

**Warning:** This routine will overwrite the contents of RAM locations \$0090 – \$00CA.

### 3.2.42 UINT16 TPMS\_FLASH\_CHECK (void)

- **Description:** This function calculates the CRC16 checksum for the NXP firmware area (addresses \$E000 – FFAD) using the function TPMS\_CRC16. It compares it with a pre-calculated stored value and reports if these two values match or not.
- **Stack size:** 16 bytes
- **Approx. Duration:** 226800  $\mu$ s
- **Power management:** This function executes entirely in RUN mode.
- **Interrupt management:** This function does not await any interrupts. It will not be affected by interrupts.
- **Resources:** N/A
- **Input parameters:**
  - None
- **Returns:**
  - UINT16 u16Status: "0" in case the calculated checksum and the stored one are the same, or the calculated checksum in case they are different.

*Note: This function is not correctly implemented so does not assess the state of the FLASH.*

**Warning:** This function is not correctly implemented meaning that it exists and can be executed by the user, but it will not return the expected data described above. The data returned will be incorrect so must not be used by the application. This implies the user should avoid using this function.

### 3.2.43 UINT8 TPMS\_FLASH\_ERASE (UINT16 u16Address)

- **Description:** This function erases 1 page (512 bytes) of flash at a time.
- **Stack size:** 11 bytes
- **Approx. Duration:** 23810  $\mu$ s.
- **Power management:** This function executes entirely in RUN mode.
- **Interrupt management:** This function does not await any interrupts. It may be affected by interrupts.
- **Resources:** Global RAM locations \$0090 – \$00CA
- **Input parameters:**
  - UINT16 u16Address: any given address. The whole page where this address resides will be erased (i.e. if u16Address = \$D234, the contents of addresses \$D200 – \$D3FF will be erased).
- **Returns:**
  - Zero if the page was erased successfully; else, one.

*Note: If u16Address is within NXP firmware section, the erase command will not be performed but the return value will be zero.*

**Warning:** This routine will overwrite the contents of RAM locations \$0090– \$00CA.

### 3.2.44 UINT8 TPMS\_FLASH\_PROTECTION (UINT16 u16Key)

- **Description:** This function enables flash protection for the complete user block. After its execution, both TPMS\_FLASH\_WRITE and TPMS\_FLASH\_ERASE will become disabled permanently. It will also block any customer boot loader from successfully writing to any location. Re-programming of the device can only be achieved through BDM after execution of this routine.

- **Stack size:** 11 bytes
- **Approx. Duration:** 736 µs if protecting; 20.4 µs for a failed attempt.
- **Power management:** This function executes entirely in RUN mode.
- **Interrupt management:** This function does not await any interrupts. It will be affected by interrupts.
- **Resources:** Global RAM locations \$0090 – \$00CA.
- **Input parameters:**
  - UINT16 u16Key: Due to the irreversible status after the execution of this routine, this argument is used as a fail-safe to guarantee desired execution of the function. Only when u16Key is equal to the least-significant word of the UniqueID will this function execute successfully.
- **Returns:**
  - UINT8 u8Status: according to [Table 29](#).

**Table 29. Possible status values for TPMS\_FLASH\_PROTECTION**

Return Value	Description
\$0	u16Key matches lower 16-bits of UniqueID; protection was disabled and now is enabled.
\$1	u16Key does not match lower 16-bits of UniqueID; protection was disabled and continues to be so.
\$2	u16Key matches lower 16-bits of UniqueID; protection was already enabled.
\$3	u16Key does not match lower 16-bits of UniqueID; protection was already enabled.
\$4	u16Key matches lower 16-bits of UniqueID; protection was disabled and continues to be so (failed writing protection).
\$5 – \$FF	Reserved.

**Warning:** This routine can only be executed once. After successful execution of this routine, TPMS\_FLASH\_WRITE and TPMS\_FLASH\_ERASE will be permanently disabled.

**3.2.45 void TPMS\_MULT\_SIGN\_INT16 (INT16 i16Mult1, INT16 i16Mult2, INT32\* pi32Result)**

- **Description:** This function will multiply two signed 16-bit numbers together.
- **Stack size:** 17 bytes
- **Approx. Duration:** 60 µs
- **Power management:** This function executes entirely in RUN mode.
- **Interrupt management:** This function does not await any interrupts. It should not be affected by interrupts.
- **Resources:** N/A
- **Input parameters:**
  - INT16 i16Mult1: First multiplier.
  - INT16 i16Mult2: Second multiplier.
  - INT32\* pi32Result: Pointer to a 32-bit variable where the result will be stored.
- **Returns:**
  - void.

### 3.2.46 UIN16 TPMS\_WAVG(UIN16 u8PNew, UIN16 u16POld, UIN16 u8AVg)

- **Description:** This subroutine calculates a new weighed average value for a given new and old measurement readings by using the following equation:

$$u16NewAverage = ((u16POld \times (u8AVG - 1) + u8PNew) / (u8AVG))$$

- **Stack size:** 12 bytes
- **Approx. Duration:** 38  $\mu$ s (average of 2), 43  $\mu$ s (average of 4), 48  $\mu$ s (average of 8), 53  $\mu$ s (average of 16), 56  $\mu$ s (average of 32).
- **Power management:** This function executes entirely in RUN mode.
- **Interrupt management:** This function does not await any interrupts. It will not be affected by interrupts.
- **Resources:** N/A
- **Input parameters:**
  - UIN16 u8PNew: new value to include in average.
  - UIN16 u16POld: Old average.
  - UIN16 u8AVg: Weight of the average. This value can be 2, 4, 8, 16, 32; any other value will return an incorrect response.
- **Returns:**
  - UIN16 u8NewAverage: resulting weighed average of both old average and the new value (refer to Example 1).

### 3.2.47 void TPMS\_RDE\_ADJUST\_PRESSURE (UIN16\* pu16UUMA, T\_RDE\* ptRDEValues)

- **Description:** This routine's functionality has been removed, but its prototype is still callable for backward compatibility. It always returns CLEAR, and doesn't affect any passed argument.
- **Stack size:** 7 bytes
- **Approx. Duration:** 85  $\mu$ s
- **Power management:** This function does not await any interrupts and should not be affected by interrupts.
- **Interrupt management:** This function does not await any interrupts and should not be affected by interrupts.
- **Resources:** Core
- **Input parameters:**
  - UIN16 \*u16UUMA: Pointer to Universal Uncompensated Measurement Array (as described in [Section 2.5 "Rapid Decompression Event Array \(T\\_RDE\) Format"](#)). No values are affected.
  - T\_RDE\* ptRDEValues: For more information on the RDE structure, refer to [Section 2.5 "Rapid Decompression Event Array \(T\\_RDE\) Format"](#).
- **Returns:**
  - UIN16 u8Status: Always CLEAR.



## 4 Revision history

### Revision history

Revision number	Date	Description
2.3	20180501	<ul style="list-style-type: none"> <li>Added new paragraph in <a href="#">Section 2.1.1 "TPMS_INTERRUPT_FLAG"</a> before first paragraph.</li> <li>Revised u*Status Value column in <a href="#">Table 14</a> from "\$08" to "\$04" and "\$28" to "\$24".</li> <li>Revised u*Status Value column in <a href="#">Table 16</a> from "\$08" to "\$04" and "\$28" to "\$24".</li> <li>Revised u*Status Value column in <a href="#">Table 19</a> from "\$08" to "\$04" and "\$28" to "\$24" and revised Condition column from "Uncompensated X acceleration reading..." to "Uncompensated X and/or Y acceleration reading...". Removed rows with u8Status values of \$10, \$30, \$18, and \$38.</li> <li>Revised "Table xx" to "<a href="#">Table 21</a>" in <a href="#">Section 3.2.18</a>.</li> <li>Removed "This routine is known to be inexact. Avoid its use if possible." from the warning in <a href="#">Section 3.2.20</a>.</li> <li>Added Note to description item "Returns" in <a href="#">Section 3.2.20</a> and additional content to "Warning".</li> <li>Added Note to description item "Returns" in <a href="#">Section 3.2.35</a> and additional content to "Warning".</li> <li>Revised content for "Description" in <a href="#">Section 3.2.38</a>.</li> <li>Added Note to description item "Returns" in <a href="#">Section 3.2.42</a> and additional content to "Warning".</li> <li>Added Note to description item "Returns" in <a href="#">Section 3.2.43</a>.</li> </ul>
2.2	20170308	<ul style="list-style-type: none"> <li>The format of this data sheet has been redesigned to comply with the new identity guidelines of NXP Semiconductors. Legal texts have been adapted to the new company name where appropriate.</li> <li>Added new content after the third sentence in the first paragraph starting with "If an LFR interrupt occurs ... has consumed too much time." in <a href="#">Section 2.1.1</a>.</li> <li>Added new content "The watchdog is automatically restarted when the program goes back in RUN mode." at the end of the first paragraph in <a href="#">Section 2.1.1</a>.</li> <li>Added new content to the power management item starting with "It requires the MCU ... making the call" in <a href="#">Section 3.2.19</a>.</li> <li>Added "Prior to calling this routine, the RFM must be enabled." to the warning at the end of <a href="#">Section 3.2.19</a>.</li> <li>Revised the content of the description item in <a href="#">Section 3.2.20</a>.</li> <li>Added new content to the power management item starting with "It requires the MCU ... making the call" in <a href="#">Section 3.2.20</a>.</li> <li>Added new item "When BIT5 of u8PowerManagement is set, find the best RF power setting (RFCFR2_PWR) dynamically based on voltage, temperature, and current carrier frequency in order to target 3 dBm as actual output power. This value of 3 dBm can be increased or decreased in given temperature ranges using the offsets (0.5 dBm/count) in the pu8PowerManagement array." in <a href="#">Section 3.2.29</a>.</li> <li>Added three rows and revised all descriptions in <a href="#">Table 24</a> in <a href="#">Section 3.2.29</a>.</li> <li>Revised the content of the description item in <a href="#">Section 3.2.39</a>.</li> </ul>
2.1	2014-10	Updated values for Page-1 register LFCTRLD for Bits 4 and 3 from 0 to 1 in <a href="#">Table 4</a>



Revision number	Date	Description
2.0	2014-10	<ul style="list-style-type: none"><li>• Removed "Xtrinsic" from document title in <a href="#">Section 1</a>.</li><li>• Removed "Some functionality may not be present in all derivatives." from the first paragraph of <a href="#">Section 1</a>.</li><li>• Updated UINT8 entry description changing "Plock" to "Clock" in <a href="#">Paragraph</a>.</li><li>• Added section <a href="#">Section 2.6</a>.</li><li>• Updated Approx. Duration bullet from "216" to "900" in <a href="#">Section 3.2.7</a>.</li><li>• Updated Approx. Duration bullet from "216" to "955" in <a href="#">Section 3.2.10</a> and <a href="#">Section 3.2.13</a>.</li><li>• Changed table heading from "TPMS_READ_ACCELERATION_X" to "TPMS_READ_ACCELERATION_Z" in <a href="#">Table 17</a>.</li><li>• Revised the content of each bullet in <a href="#">Section 3.2.47</a>.</li></ul>
1.01	2014-07	Initial release.

## 5 Legal information

### 5.1 Definitions

**Draft** — The document is a draft version only. The content is still under internal review and subject to formal approval, which may result in modifications or additions. NXP Semiconductors does not give any representations or warranties as to the accuracy or completeness of information included herein and shall have no liability for the consequences of use of such information.

### 5.2 Disclaimers

**Limited warranty and liability** — Information in this document is believed to be accurate and reliable. However, NXP Semiconductors does not give any representations or warranties, expressed or implied, as to the accuracy or completeness of such information and shall have no liability for the consequences of use of such information. NXP Semiconductors takes no responsibility for the content in this document if provided by an information source outside of NXP Semiconductors. In no event shall NXP Semiconductors be liable for any indirect, incidental, punitive, special or consequential damages (including - without limitation - lost profits, lost savings, business interruption, costs related to the removal or replacement of any products or rework charges) whether or not such damages are based on tort (including negligence), warranty, breach of contract or any other legal theory. Notwithstanding any damages that customer might incur for any reason whatsoever, NXP Semiconductors' aggregate and cumulative liability towards customer for the products described herein shall be limited in accordance with the Terms and conditions of commercial sale of NXP Semiconductors.

**Right to make changes** — NXP Semiconductors reserves the right to make changes to information published in this document, including without limitation specifications and product descriptions, at any time and without notice. This document supersedes and replaces all information supplied prior to the publication hereof.

**Applications** — Applications that are described herein for any of these products are for illustrative purposes only. NXP Semiconductors makes no representation or warranty that such applications will be suitable for the specified use without further testing or modification. Customers are responsible for the design and operation of their applications and

products using NXP Semiconductors products, and NXP Semiconductors accepts no liability for any assistance with applications or customer product design. It is customer's sole responsibility to determine whether the NXP Semiconductors product is suitable and fit for the customer's applications and products planned, as well as for the planned application and use of customer's third party customer(s). Customers should provide appropriate design and operating safeguards to minimize the risks associated with their applications and products. NXP Semiconductors does not accept any liability related to any default, damage, costs or problem which is based on any weakness or default in the customer's applications or products, or the application or use by customer's third party customer(s). Customer is responsible for doing all necessary testing for the customer's applications and products using NXP Semiconductors products in order to avoid a default of the applications and the products or of the application or use by customer's third party customer(s). NXP does not accept any liability in this respect.

**Suitability for use in automotive applications** — This NXP Semiconductors product has been qualified for use in automotive applications. Unless otherwise agreed in writing, the product is not designed, authorized or warranted to be suitable for use in life support, life-critical or safety-critical systems or equipment, nor in applications where failure or malfunction of an NXP Semiconductors product can reasonably be expected to result in personal injury, death or severe property or environmental damage. NXP Semiconductors and its suppliers accept no liability for inclusion and/or use of NXP Semiconductors products in such equipment or applications and therefore such inclusion and/or use is at the customer's own risk.

**Export control** — This document as well as the item(s) described herein may be subject to export control regulations. Export might require a prior authorization from competent authorities.

**Translations** — A non-English (translated) version of a document is for reference only. The English version shall prevail in case of any discrepancy between the translated and English versions.

### 5.3 Trademarks

Notice: All referenced brands, product names, service names and trademarks are the property of their respective owners.

**Tables**

Tab. 1.	TPMS_INTERRUPT_FLAG format and trigger conditions .....2	Tab. 15.	Valid output conditions for TPMS_COMP_ACCELERATION_X ..... 18
Tab. 2.	Error Status Fields ..... 3	Tab. 16.	u8DynamicOffset valid values ..... 19
Tab. 3.	Universal Uncompensated Measurement Array .....5	Tab. 17.	Valid output conditions for TPMS_READ_ACCELERATION_Z .....20
Tab. 4.	Customer-configurable TMPS and LF Register with SENS = 1 .....7	Tab. 18.	Valid output conditions for TPMS_COMP_ACCELERATION_Z .....21
Tab. 5.	Customer-configurable TMPS and LF Register with SENS = 2 .....7	Tab. 19.	Valid output conditions for TPMS_READ_ACCELERATION_XZ ..... 22
Tab. 6.	FXTH87xx22's Firmware Function jump table .....8	Tab. 20.	Valid output conditions for TPMS_COMP_ACCELERATION_XZ ..... 24
Tab. 7.	Valid output conditions for TPMS_READ_VOLTAGE .....11	Tab. 21.	Valid output conditions for TPMS_READ_V0 and TPMS_READ_V1 ..... 25
Tab. 8.	Valid output conditions for TPMS_COMP_VOLTAGE ..... 11	Tab. 22.	u16RFPParam Array format ..... 29
Tab. 9.	Valid output conditions for TPMS_READ_TEMPERATURE .....12	Tab. 23.	Description of Element 0 in the u16RFPParam Array .....29
Tab. 10.	Valid output conditions for TPMS_COMP_TEMPERATURE .....13	Tab. 24.	*pu8PowerManagement format .....30
Tab. 11.	Valid output conditions for TPMS_READ_PRESSURE ..... 14	Tab. 25.	pu8PowerManagement[0] format ..... 31
Tab. 12.	Valid output conditions for TPMS_COMP_PRESSURE ..... 15	Tab. 26.	u8Code format ..... 34
Tab. 13.	u8DynamicOffset valid values ..... 16	Tab. 27.	u8TestMask format .....36
Tab. 14.	Valid output conditions for TPMS_READ_ACCELERATION_X ..... 16	Tab. 28.	u8Status valid values for TPMS_WIRE_AND_ADC_CHECK .....36
		Tab. 29.	Possible status values for TPMS_FLASH_PROTECTION .....38

**Figures**

Fig. 1.	Measurement Signal Range Definitions ..... 3	Fig. 2.	Description of the physical layer on the FXTH87xx22 Simulated SPI interface .....6
---------	--	---------	--

**Contents**

<b>1</b>	<b>Introduction</b> .....	<b>1</b>	3.2.16	UINT8	TPMS_COMP_ACCELERATION_XZ (UINT16 *u16CompAccel, UINT16* u16UUMA) .....	23
<b>2</b>	<b>Globals and formats</b> .....	<b>1</b>	3.2.17	UINT8	TPMS_READ_V0 (UINT16 *u16Result, UINT8 u8Avg) .....	24
2.1	Global variables .....	1	3.2.18	UINT8	TPMS_READ_V1 (UINT16 *u16Result, UINT8 u8Avg) .....	25
2.1.1	TPMS_INTERRUPT_FLAG .....	1	3.2.19	UINT8	TPMS_LFOCAL (void) .....	25
2.2	Measurement error format .....	2	3.2.20	UINT8	TPMS_MFOCAL (void) .....	26
2.2.1	Definition of Signal Ranges .....	2	3.2.21	void	TPMS_RF_ENABLE (UINT8 u8Switch) ...	26
2.2.2	Error Status Format .....	3	3.2.22	void	TPMS_RF_RESET (void) .....	27
2.3	Universal Uncompensated Measurement Array (UUMA) format .....	4	3.2.23	void	TPMS_RF_READ_DATA (UINT8 u8Size, UINT8 *u8RAMBuffer, UINT8 u8RFMBuffer) .....	27
2.4	Simulated SPI interface Signal Format .....	5	3.2.24	void	TPMS_RF_READ_DATA_REVERSE (UINT8 u8Size, UINT8 *u8RAMBuffer, UINT8 u8RFMBuffer) .....	27
2.5	Rapid Decompression Event Array (T_RDE) Format .....	6	3.2.25	void	TPMS_RF_WRITE_DATA (UINT8 u8Size, UINT8 *u8RAMBuffer, UINT8 u8RFMBuffer) .....	28
2.6	LFR registers initialized by firmware .....	6	3.2.26	void	TPMS_RF_WRITE_DATA_REVERSE (UINT8 u8Size, UINT8 *u8RAMBuffer, UINT8 u8RFMBuffer) .....	28
<b>3</b>	<b>Firmware Functions</b> .....	<b>8</b>	3.2.27	void	TPMS_RF_CONFIG_DATA (UINT16 *u16RFPParam) .....	29
3.1	Firmware jump table .....	8	3.2.28	void	TPMS_RF_SET_TX (UINT8 u8BufferSize) .....	30
3.2	Function description .....	9	3.2.29	void	TPMS_RF_DYNAMIC_POWER (UINT8 u8CompT, UINT8 u8CompV, UINT8* pu8PowerManagement) .....	30
3.2.1	void TPMS_RESET (void) .....	10	3.2.30	void	TPMS_MSG_INIT (void) .....	31
3.2.2	UINT8 TPMS_READ_VOLTAGE (UINT16 *u16UUMA) .....	10	3.2.31	UINT8	TPMS_MSG_READ (void) .....	31
3.2.3	UINT8 TPMS_COMP_VOLTAGE (UINT8 *u8CompVoltage, *UINT16 u16UUMA) .....	11	3.2.32	UINT8	TPMS_MSG_WRITE (UINT8 u8SendByte) .....	32
3.2.4	UINT8 TPMS_READ_TEMPERATURE (UINT16 *u16UUMA) .....	12	3.2.33	UINT8	TPMS_CHECKSUM_XOR (UINT8 *u8Buffer, UINT8 u8Size, UINT8 u8Checksum) .....	32
3.2.5	UINT8 TPMS_COMP_TEMPERATURE (UINT8 *u8Temp, UINT16 *u16UUMA) .....	13	3.2.34	UINT8	TPMS_CRC8 (UINT8 *u8Buffer, UINT16 u16SizeInBytes, UINT8 u8Remainder) .....	32
3.2.6	UINT8 TPMS_READ_PRESSURE (UINT16 *u16UUMA, UINT8 u8Avg) .....	13	3.2.35	UINT16	TPMS_CRC16 (UINT8 *u8Buffer, UINT16 u16MByteSize, UINT16 u16Remainder) .....	33
3.2.7	UINT8 TPMS_COMP_PRESSURE (UINT16 *u16CompPressure, UINT16 *u16UUMA) .....	14	3.2.36	UINT16	TPMS_SQUARE_ROOT (UINT16 u16Process) .....	33
3.2.8	UINT8 TPMS_READ_ACCELERATION_X (UINT16 *u16UUMA, UINT8 u8Avg, UINT8 u8FiltSelect, UINT8 u8DynamicOffset) .....	15	3.2.37	void	TPMS_READ_ID (UINT8 *u8Code, UINT8 u8Offset) .....	34
3.2.9	UINT8 TPMS_READ_DYNAMIC_ACCEL_X (UINT8 u8Filter, UINT8* u8Offset, UINT16* u16UUMA) .....	17	3.2.38	void	TPMS_LF_ENABLE (UINT8 u8Switch) ....	34
3.2.10	UINT8 TPMS_COMP_ACCELERATION_X (UINT16 *u16CompAccelX, UINT16* u16UUMA) .....	17	3.2.39	UINT8	TPMS_LF_READ_DATA (UINT8 *u8Buffer, UINT8 u8Count) .....	34
3.2.11	UINT8 TPMS_READ_ACCELERATION_Z (UINT16 *u16UUMA, UINT8 u8Avg, UINT8 u8FiltSelect, UINT8 u8DynamicOffset) .....	18	3.2.40	UINT8	TPMS_WIRE_AND_ADC_CHECK (UINT8 u8TestMask) .....	35
3.2.12	UINT8 TPMS_READ_DYNAMIC_ACCEL_Z (UINT8 u8Filter, UINT8* u8Offset, UINT16* u16UUMA) .....	20	3.2.41	void	TPMS_FLASH_WRITE (UINT16 u16Address, UINT8* u8Buffer, UINT8 u8Size) .....	36
3.2.13	UINT8 TPMS_COMP_ACCELERATION_Z (UINT16 *u16CompAccel, UINT16* u16UUMA) .....	21				
3.2.14	UINT8 TPMS_READ_ACCELERATION_XZ (UINT16 *u16UUMA, UINT8 u8Avg, UINT8 u8FiltSelect, UINT8 u8DynamicOffsetX, UINT8 u8DynamicOffsetZ) .....	22				
3.2.15	UINT8 TPMS_READ_DYNAMIC_ACCEL_XZ (UINT8 u8Filter, UINT8* u8OffsetX, UINT8* u8OffsetZ, UINT16* u16UUMA) .....	23				

3.2.42 UINT16 TPMS\_FLASH\_CHECK (void) ..... 37

3.2.43 UINT8 TPMS\_FLASH\_ERASE (UINT16  
u16Address) .....37

3.2.44 UINT8 TPMS\_FLASH\_PROTECTION  
(UINT16 u16Key) .....37

3.2.45 void TPMS\_MULT\_SIGN\_INT16 (INT16  
i16Mult1, INT16 i16Mult2, INT32\*  
pi32Result) ..... 38

3.2.46 UINT16 TPMS\_WAVG(UINT8 u8PNew,  
UINT16 u16POld, UINT8 u8Avg) .....39

3.2.47 void TPMS\_RDE\_ADJUST\_PRESSURE  
(UINT16\* pu16UUMA, T\_RDE\*  
ptRDEValues) ..... 39

**4 Revision history ..... 40**

**5 Legal information ..... 42**

---

Please be aware that important notices concerning this document and the product(s) described herein, have been included in section 'Legal information'.

---

© NXP B.V. 2018.

All rights reserved.

For more information, please visit: <http://www.nxp.com>

For sales office addresses, please send an email to: [salesaddresses@nxp.com](mailto:salesaddresses@nxp.com)

Date of release: 1 May 2018