

LM5112 Tiny 7A MOSFET Gate Driver

Check for Samples: [LM5112](#)

FEATURES

- Compound CMOS and bipolar outputs reduce output current variation
- 7A sink/3A source current
- Fast propagation times (25 ns typical)
- Fast rise and fall times (14 ns/12 ns rise/fall with 2 nF load)
- Inverting and non-inverting inputs provide either configuration with a single device
- Supply rail under-voltage lockout protection
- Dedicated input ground (IN_REF) for split supply or single supply operation
- Power Enhanced 6-pin LLP package (3.0mm x 3.0mm) or thermally enhanced MSOP8-EP package
- Output swings from V_{CC} to V_{EE} which can be negative relative to input ground

DESCRIPTION

The LM5112 MOSFET gate driver provides high peak gate drive current in the tiny LLP-6 package (SOT23 equivalent footprint) or an 8-Lead exposed-pad MSOP package, with improved power dissipation required for high frequency operation. The compound output driver stage includes MOS and bipolar transistors operating in parallel that together sink more than 7A peak from capacitive loads. Combining the unique characteristics of MOS and bipolar devices reduces drive current variation with voltage and temperature. Under-voltage lockout protection is provided to prevent damage to the MOSFET due to insufficient gate turn-on voltage. The LM5112 provides both inverting and non-inverting inputs to satisfy requirements for inverting and non-inverting gate drive with a single device type.

Block Diagram

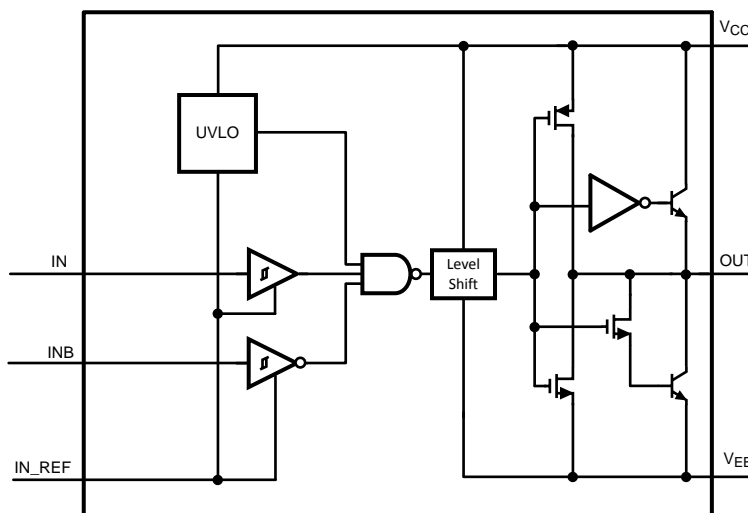

Figure 1. Block Diagram of LM5112



Please be aware that an important notice concerning availability, standard warranty, and use in critical applications of Texas Instruments semiconductor products and disclaimers thereto appears at the end of this data sheet.

All trademarks are the property of their respective owners.

Pin Configurations

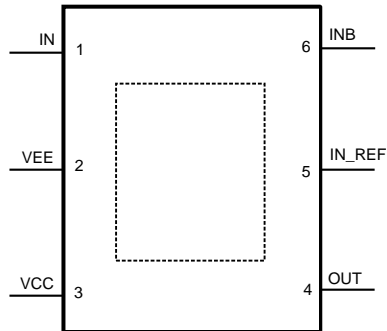

Figure 2. LLP-6

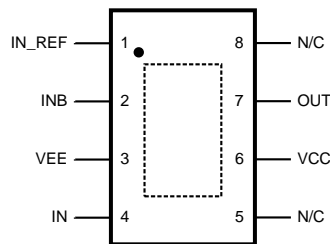

Figure 3. MSOP8-EP

Pin Functions

Pin Descriptions

Pin		Name	Description	Application Information
LLP-6	MSOP-8			
1	4	IN	Non-inverting input pin	TTL compatible thresholds. Pull up to VCC when not used.
2	3	VEE	Power ground for driver outputs	Connect to either power ground or a negative gate drive supply for positive or negative voltage swing.
3	6	VCC	Positive Supply voltage input	Locally decouple to VEE. The decoupling capacitor should be located close to the chip.
4	7	OUT	Gate drive output	Capable of sourcing 3A and sinking 7A. Voltage swing of this output is from VEE to VCC.
5	1	IN_REF	Ground reference for control inputs	Connect to power ground (VEE) for standard positive only output voltage swing. Connect to system logic ground when VEE is connected to a negative gate drive supply.
6	2	INB	Inverting input pin	TTL compatible thresholds. Connect to IN_REF when not used.
---	5, 8	N/C	Not internally connected	
---	---	Exposed Pad	Exposed Pad, underside of package	Internally bonded to the die substrate. Connect to VEE ground pin for low thermal impedance.



These devices have limited built-in ESD protection. The leads should be shorted together or the device placed in conductive foam during storage or handling to prevent electrostatic damage to the MOS gates.

Absolute Maximum Ratings ⁽¹⁾

V_{CC} to V_{EE}	-0.3V to 15V
V_{CC} to IN_REF	-0.3V to 15V
IN/INB to IN_REF	-0.3V to 15V
IN_REF to V_{EE}	-0.3V to 5V
Storage Temperature Range	-55°C to +150°C
Maximum Junction Temperature	+150°C
Operating Junction Temperature	-40°C+125°C
ESD Rating	2kV

(1) Absolute Maximum Ratings are limits beyond which damage to the device may occur. Operating Ratings are conditions under which operation of the device is intended to be functional. For guaranteed specifications and test conditions, see the Electrical Characteristics.

Electrical Characteristics

$T_J = -40^{\circ}\text{C}$ to $+125^{\circ}\text{C}$, $V_{CC} = 12\text{V}$, $\text{INB} = \text{IN_REF} = V_{EE} = 0\text{V}$, No Load on output, unless otherwise specified.

SYMBOL	PARAMETER	CONDITIONS	MIN	TYP	MAX	UNITS
SUPPLY						
V_{CC}	V_{CC} Operating Range	$V_{CC} - \text{IN_REF}$ and $V_{CC} - V_{EE}$	3.5		14	V
UVLO	V_{CC} Under-voltage Lockout (rising)	$V_{CC} - \text{IN_REF}$	2.4	3.0	3.5	V
V_{CCH}	V_{CC} Under-voltage Hysteresis			230		mV
I_{CC}	V_{CC} Supply Current			1.0	2.0	mA
CONTROL INPUTS						
V_{IH}	Logic High		2.3			V
V_{IL}	Logic Low				0.8	V
V_{thH}	High Threshold		1.3	1.75	2.3	V
V_{thL}	Low Threshold		0.8	1.35	2.0	V
HYS	Input Hysteresis			400		mV
I_{iL}	Input Current Low	$\text{IN} = \text{INB} = 0\text{V}$	-1	0.1	1	μA
I_{iH}	Input Current High	$\text{IN} = \text{INB} = V_{CC}$	-1	0.1	1	μA
OUTPUT DRIVER						
R_{OH}	Output Resistance High	$I_{OUT} = -10\text{mA}$ ⁽¹⁾		30	50	Ω
R_{OL}	Output Resistance Low	$I_{OUT} = 10\text{mA}$ ⁽¹⁾		1.4	2.5	Ω
I_{SOURCE}	Peak Source Current	$\text{OUT} = V_{CC}/2$, 200ns pulsed current		3		A
I_{SINK}	Peak Sink Current	$\text{OUT} = V_{CC}/2$, 200ns pulsed current		7		A
SWITCHING CHARACTERISTICS						
td1	Propagation Delay Time Low to High, IN/ INB rising (IN to OUT)	$C_{LOAD} = 2\text{ nF}$, see Figure 4 and Figure 5		25	40	ns
td2	Propagation Delay Time High to Low, IN / INB falling (IN to OUT)	$C_{LOAD} = 2\text{ nF}$, see Figure 4 and Figure 5		25	40	ns
tr	Rise time	$C_{LOAD} = 2\text{ nF}$, see Figure 4 and Figure 5		14		ns
tf	Fall time	$C_{LOAD} = 2\text{ nF}$, see Figure 4 and Figure 5		12		ns
LATCHUP PROTECTION						
	AEC -Q100, METHOD 004	$T_J = 150^{\circ}\text{C}$		500		mA
THERMAL RESISTANCE						
θ_{JA}	Junction to Ambient, 0 LFPM Air Flow	LLP-6 Package MSOP8-EP Package		40 60		$^{\circ}\text{C/W}$
θ_{JC}	Junction to Case	LLP-6 Package MSOP8-EP Package		7.5 4.7		$^{\circ}\text{C/W}$

- (1) The output resistance specification applies to the MOS device only. The total output current capability is the sum of the MOS and Bipolar devices.

Timing Waveforms

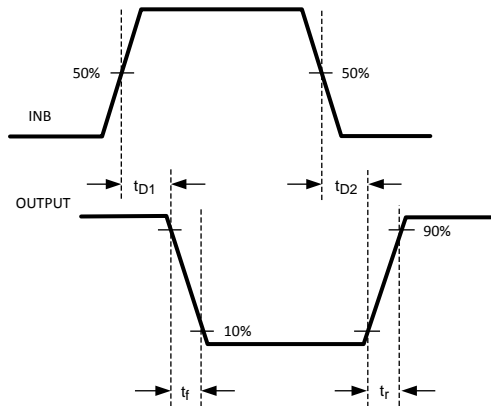

Figure 4. Inverting

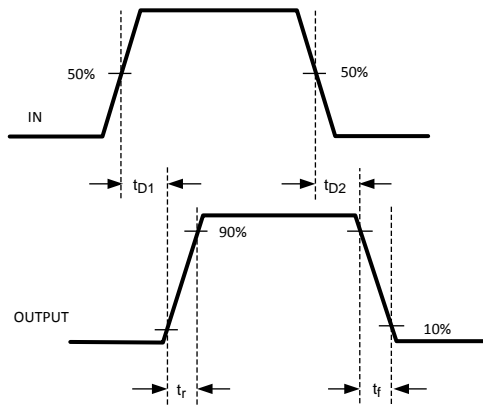
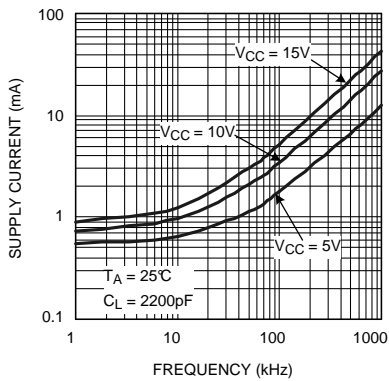

Figure 5. Non-Inverting

Typical Performance Characteristics

Supply Current vs Frequency



Supply Current vs Capacitive Load

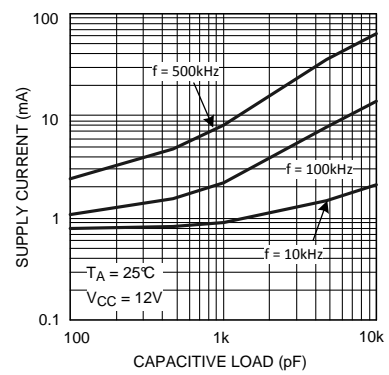

Rise and Fall Time vs Supply Voltage

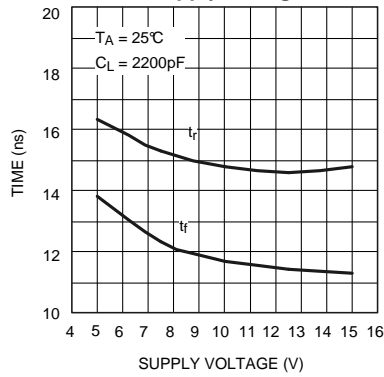

Rise and Fall Time vs Temperature

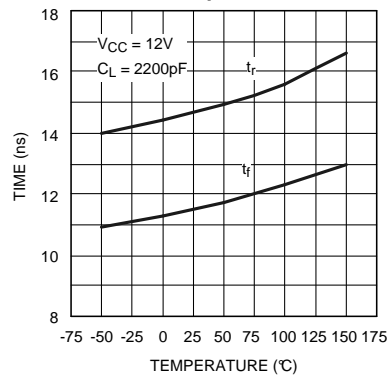

Rise and Fall Time vs Capacitive Load

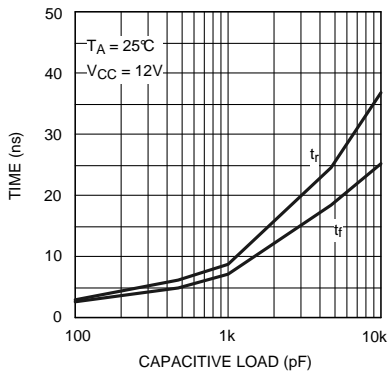

Delay Time vs Supply Voltage

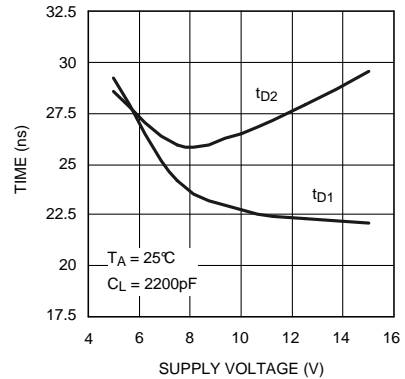

Typical Performance Characteristics (continued)

Delay Time vs Temperature

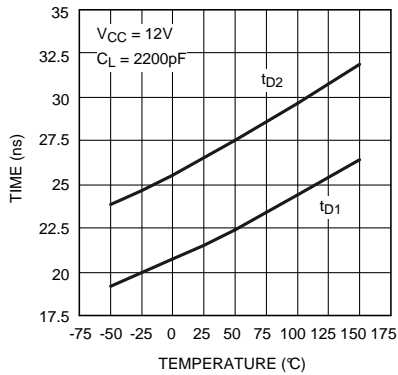

RDSON vs Supply Voltage

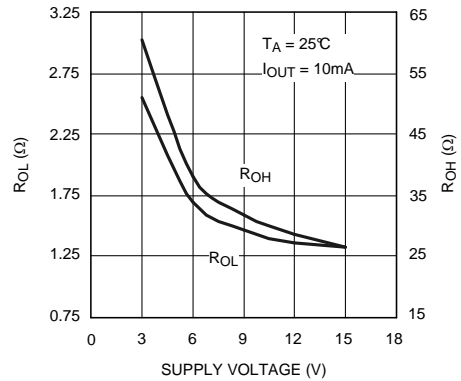

UVLO Thresholds and Hysteresis vs Temperature

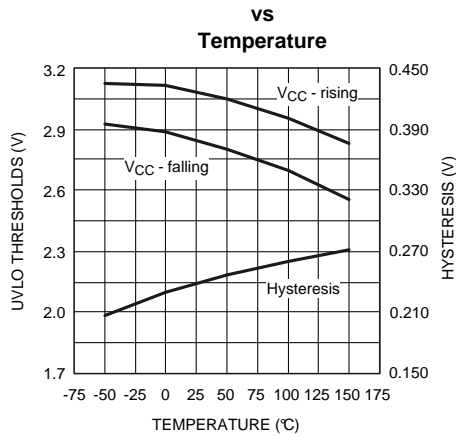

Peak Current vs Supply Voltage

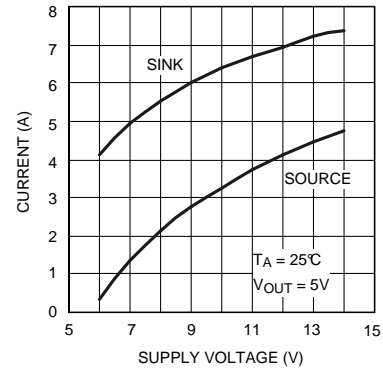

Simplified Application Block Diagram

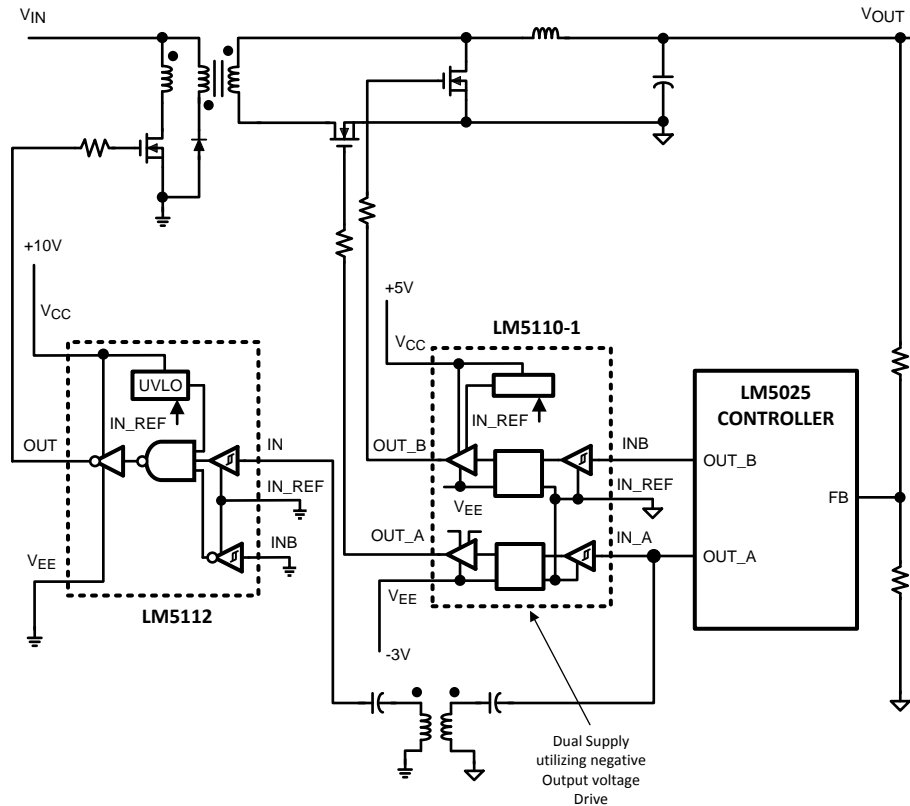

Figure 6. Simplified Application Block Diagram

Detailed Operating Description

The LM5112 is a high speed, high peak current (7A) single channel MOSFET driver. The high peak output current of the LM5112 will switch power MOSFET's on and off with short rise and fall times, thereby reducing switching losses considerably. The LM5112 includes both inverting and non-inverting inputs that give the user flexibility to drive the MOSFET with either active low or active high logic signals. The driver output stage consists of a compound structure with MOS and bipolar transistor operating in parallel to optimize current capability over a wide output voltage and operating temperature range. The bipolar device provides high peak current at the critical Miller plateau region of the MOSFET V_{GS} , while the MOS device provides rail-to-rail output swing. The totem pole output drives the MOSFET gate between the gate drive supply voltage V_{CC} and the power ground potential at the V_{EE} pin.

The control inputs of the driver are high impedance CMOS buffers with TTL compatible threshold voltages. The negative supply of the input buffer is connected to the input ground pin IN_REF . An internal level shifting circuit connects the logic input buffers to the totem pole output drivers. The level shift circuit and separate input/output ground pins provide the option of single supply or split supply configurations. When driving the MOSFET gates from a single positive supply, the IN_REF and V_{EE} pins are both connected to the power ground.

The isolated input and output stage grounds provide the capability to drive the MOSFET to a negative V_{GS} voltage for a more robust and reliable off state. In split supply configuration, the IN_REF pin is connected to the ground of the controller which drives the LM5112 inputs. The V_{EE} pin is connected to a negative bias supply that can range from the IN_REF potential to as low as 14 V below the V_{CC} gate drive supply. For reliable operation, the maximum voltage difference between V_{CC} and IN_REF or between V_{CC} and V_{EE} is 14V.

The minimum recommended operating voltage between V_{CC} and IN_REF is 3.5V. An Under Voltage Lock Out (UVLO) circuit is included in the LM5112 which senses the voltage difference between V_{CC} and the input ground pin, IN_REF . When the V_{CC} to IN_REF voltage difference falls below 2.8V the driver is disabled and the output pin is held in the low state. The UVLO hysteresis prevents chattering during brown-out conditions; the driver will resume normal operation when the V_{CC} to IN_REF differential voltage exceeds 3.0V.

Layout Considerations

Attention must be given to board layout when using LM5112. Some important considerations include:

1. A Low ESR/ESL capacitor must be connected close to the IC and between the V_{CC} and V_{EE} pins to support high peak currents being drawn from V_{CC} during turn-on of the MOSFET.
2. Proper grounding is crucial. The driver needs a very low impedance path for current return to ground avoiding inductive loops. Two paths for returning current to ground are a) between LM5112 IN_REF pin and the ground of the circuit that controls the driver inputs and b) between LM5112 V_{EE} pin and the source of the power MOSFET being driven. Both paths should be as short as possible to reduce inductance and be as wide as possible to reduce resistance. These ground paths should be distinctly separate to avoid coupling between the high current output paths and the logic signals that drive the LM5112. With rise and fall times in the range of 10 to 30nsec, care is required to minimize the lengths of current carrying conductors to reduce their inductance and EMI from the high di/dt transients generated when driving large capacitive loads.
3. If either channel is not being used, the respective input pin (IN or INB) should be connected to either V_{EE} or V_{CC} to avoid spurious output signals.

Thermal Performance

INTRODUCTION

The primary goal of the thermal management is to maintain the integrated circuit (IC) junction temperature (T_j) below a specified limit to ensure reliable long term operation. The maximum T_j of IC components should be estimated in worst case operating conditions. The junction temperature can be calculated based on the power dissipated on the IC and the junction to ambient thermal resistance θ_{JA} for the IC package in the application board and environment. The θ_{JA} is not a given constant for the package and depends on the PCB design and the operating environment.

DRIVE POWER REQUIREMENT CALCULATIONS IN LM5112

LM5112 is a single low side MOSFET driver capable of sourcing / sinking 3A / 7A peak currents for short intervals to drive a MOSFET without exceeding package power dissipation limits. High peak currents are required to switch the MOSFET gate very quickly for operation at high frequencies.

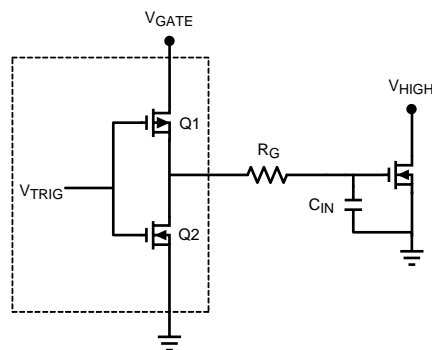

The schematic above shows a conceptual diagram of the LM5112 output and MOSFET load. Q1 and Q2 are the switches within the gate driver. R_g is the gate resistance of the external MOSFET, and C_{in} is the equivalent gate capacitance of the MOSFET. The equivalent gate capacitance is a difficult parameter to measure as it is the combination of C_{gs} (gate to source capacitance) and C_{gd} (gate to drain capacitance). The C_{gd} is not a constant and varies with the drain voltage. The better way of quantifying gate capacitance is the gate charge Q_g in coulombs. Q_g combines the charge required by C_{gs} and C_{gd} for a given gate drive voltage V_{gate} . The gate resistance R_g is usually very small and losses in it can be neglected. The total power dissipated in the MOSFET driver due to gate charge is approximated by:

$$P_{\text{DRIVER}} = V_{\text{GATE}} \times Q_{\text{G}} \times F_{\text{SW}} \quad (1)$$

Where

F_{SW} = switching frequency of the MOSFET.

For example, consider the MOSFET MTD6N15 whose gate charge specified as 30 nC for $V_{\text{GATE}} = 12\text{V}$.

Therefore, the power dissipation in the driver due to charging and discharging of MOSFET gate capacitances at switching frequency of 300 kHz and V_{GATE} of 12V is equal to

$$P_{\text{DRIVER}} = 12\text{V} \times 30 \text{ nC} \times 300 \text{ kHz} = 0.108\text{W}. \quad (2)$$

In addition to the above gate charge power dissipation, - transient power is dissipated in the driver during output transitions. When either output of the LM5112 changes state, current will flow from V_{CC} to V_{EE} for a very brief interval of time through the output totem-pole N and P channel MOSFETs. The final component of power dissipation in the driver is the power associated with the quiescent bias current consumed by the driver input stage and Under-voltage lockout sections.

Characterization of the LM5112 provides accurate estimates of the transient and quiescent power dissipation components. At 300 kHz switching frequency and 30 nC load used in the example, the transient power will be 8 mW. The 1 mA nominal quiescent current and 12V V_{GATE} supply produce a 12 mW typical quiescent power.

Therefore the total power dissipation

$$P_{\text{D}} = 0.118 + 0.008 + 0.012 = 0.138\text{W}. \quad (3)$$

We know that the junction temperature is given by

$$T_{\text{J}} = P_{\text{D}} \times \theta_{\text{JA}} + T_{\text{A}} \quad (4)$$

Or the rise in temperature is given by

$$T_{\text{RISE}} = T_{\text{J}} - T_{\text{A}} = P_{\text{D}} \times \theta_{\text{JA}} \quad (5)$$

For LLP-6 package, the integrated circuit die is attached to leadframe die pad which is soldered directly to the printed circuit board. This substantially decreases the junction to ambient thermal resistance (θ_{JA}). By providing suitable means of heat dispersion from the IC to the ambient through exposed copper pad, which can readily dissipate heat to the surroundings, θ_{JA} as low as 40°C / Watt is achievable with the package. The resulting Trise for the driver example above is thereby reduced to just 5.5 degrees.

Therefore T_{RISE} is equal to

$$T_{\text{RISE}} = 0.138 \times 40 = 5.5^{\circ}\text{C} \quad (6)$$

For MSOP8-EP θ_{JA} is typically 60°C/W.

PACKAGING INFORMATION

Orderable Device	Status (1)	Package Type	Package Drawing	Pins	Package Qty	Eco Plan (2)	Lead/Ball Finish	MSL Peak Temp (3)	Op Temp (°C)	Top-Side Markings (4)	Samples
LM5112MY	ACTIVE	MSOP- PowerPAD	DGN	8	1000	TBD	Call TI	Call TI		SJJB	Samples
LM5112MY/NOPB	ACTIVE	MSOP- PowerPAD	DGN	8	1000	Green (RoHS & no Sb/Br)	CU SN	Level-1-260C-UNLIM		SJJB	Samples
LM5112MYX	ACTIVE	MSOP- PowerPAD	DGN	8	3500	TBD	Call TI	Call TI		SJJB	Samples
LM5112MYX/NOPB	ACTIVE	MSOP- PowerPAD	DGN	8	3500	Green (RoHS & no Sb/Br)	CU SN	Level-1-260C-UNLIM		SJJB	Samples
LM5112Q1SD/NOPB	ACTIVE	WSON	NGG	6	1000	Green (RoHS & no Sb/Br)	CU SN	Level-1-260C-UNLIM	-40 to 125	L250B	Samples
LM5112Q1SDX/NOPB	ACTIVE	WSON	NGG	6	4500	Green (RoHS & no Sb/Br)	CU SN	Level-1-260C-UNLIM	-40 to 125	L250B	Samples
LM5112SD	ACTIVE	WSON	NGG	6	1000	TBD	Call TI	Call TI	-40 to 125	L132B	Samples
LM5112SD/NOPB	ACTIVE	WSON	NGG	6	1000	Green (RoHS & no Sb/Br)	CU SN	Level-1-260C-UNLIM	-40 to 125	L132B	Samples
LM5112SDX	ACTIVE	WSON	NGG	6	4500	TBD	Call TI	Call TI	-40 to 125	L132B	Samples
LM5112SDX/NOPB	ACTIVE	WSON	NGG	6	4500	Green (RoHS & no Sb/Br)	CU SN	Level-1-260C-UNLIM	-40 to 125	L132B	Samples

(1) The marketing status values are defined as follows:

ACTIVE: Product device recommended for new designs.

LIFEBUY: TI has announced that the device will be discontinued, and a lifetime-buy period is in effect.

NRND: Not recommended for new designs. Device is in production to support existing customers, but TI does not recommend using this part in a new design.

PREVIEW: Device has been announced but is not in production. Samples may or may not be available.

OBSOLETE: TI has discontinued the production of the device.

(2) Eco Plan - The planned eco-friendly classification: Pb-Free (RoHS), Pb-Free (RoHS Exempt), or Green (RoHS & no Sb/Br) - please check <http://www.ti.com/productcontent> for the latest availability information and additional product content details.

TBD: The Pb-Free/Green conversion plan has not been defined.

Pb-Free (RoHS): TI's terms "Lead-Free" or "Pb-Free" mean semiconductor products that are compatible with the current RoHS requirements for all 6 substances, including the requirement that lead not exceed 0.1% by weight in homogeneous materials. Where designed to be soldered at high temperatures, TI Pb-Free products are suitable for use in specified lead-free processes.

Pb-Free (RoHS Exempt): This component has a RoHS exemption for either 1) lead-based flip-chip solder bumps used between the die and package, or 2) lead-based die adhesive used between the die and leadframe. The component is otherwise considered Pb-Free (RoHS compatible) as defined above.

Green (RoHS & no Sb/Br): TI defines "Green" to mean Pb-Free (RoHS compatible), and free of Bromine (Br) and Antimony (Sb) based flame retardants (Br or Sb do not exceed 0.1% by weight in homogeneous material)

⁽³⁾ MSL, Peak Temp. -- The Moisture Sensitivity Level rating according to the JEDEC industry standard classifications, and peak solder temperature.

⁽⁴⁾ Only one of markings shown within the brackets will appear on the physical device.

Important Information and Disclaimer: The information provided on this page represents TI's knowledge and belief as of the date that it is provided. TI bases its knowledge and belief on information provided by third parties, and makes no representation or warranty as to the accuracy of such information. Efforts are underway to better integrate information from third parties. TI has taken and continues to take reasonable steps to provide representative and accurate information but may not have conducted destructive testing or chemical analysis on incoming materials and chemicals. TI and TI suppliers consider certain information to be proprietary, and thus CAS numbers and other limited information may not be available for release.

In no event shall TI's liability arising out of such information exceed the total purchase price of the TI part(s) at issue in this document sold by TI to Customer on an annual basis.

OTHER QUALIFIED VERSIONS OF LM5112, LM5112-Q1 :

- Catalog: [LM5112](#)
- Automotive: [LM5112-Q1](#)

NOTE: Qualified Version Definitions:

- Catalog - TI's standard catalog product
- Automotive - Q100 devices qualified for high-reliability automotive applications targeting zero defects

TAPE AND REEL INFORMATION

QUADRANT ASSIGNMENTS FOR PIN 1 ORIENTATION IN TAPE

*All dimensions are nominal

Device	Package Type	Package Drawing	Pins	SPQ	Reel Diameter (mm)	Reel Width W1 (mm)	A0 (mm)	B0 (mm)	K0 (mm)	P1 (mm)	W (mm)	Pin1 Quadrant
LM5112MY	MSOP-Power PAD	DGN	8	1000	178.0	12.4	5.3	3.4	1.4	8.0	12.0	Q1
LM5112MY/NOPB	MSOP-Power PAD	DGN	8	1000	178.0	12.4	5.3	3.4	1.4	8.0	12.0	Q1
LM5112MYX	MSOP-Power PAD	DGN	8	3500	330.0	12.4	5.3	3.4	1.4	8.0	12.0	Q1
LM5112MYX/NOPB	MSOP-Power PAD	DGN	8	3500	330.0	12.4	5.3	3.4	1.4	8.0	12.0	Q1
LM5112Q1SD/NOPB	WSOP	NGG	6	1000	178.0	12.4	3.3	3.3	1.0	8.0	12.0	Q1
LM5112Q1SDX/NOPB	WSOP	NGG	6	4500	330.0	12.4	3.3	3.3	1.0	8.0	12.0	Q1
LM5112SD	WSOP	NGG	6	1000	178.0	12.4	3.3	3.3	1.0	8.0	12.0	Q1
LM5112SD/NOPB	WSOP	NGG	6	1000	178.0	12.4	3.3	3.3	1.0	8.0	12.0	Q1
LM5112SDX	WSOP	NGG	6	4500	330.0	12.4	3.3	3.3	1.0	8.0	12.0	Q1
LM5112SDX/NOPB	WSOP	NGG	6	4500	330.0	12.4	3.3	3.3	1.0	8.0	12.0	Q1

TAPE AND REEL BOX DIMENSIONS

*All dimensions are nominal

Device	Package Type	Package Drawing	Pins	SPQ	Length (mm)	Width (mm)	Height (mm)
LM5112MY	MSOP-PowerPAD	DGN	8	1000	203.0	190.0	41.0
LM5112MY/NOPB	MSOP-PowerPAD	DGN	8	1000	203.0	190.0	41.0
LM5112MYX	MSOP-PowerPAD	DGN	8	3500	349.0	337.0	45.0
LM5112MYX/NOPB	MSOP-PowerPAD	DGN	8	3500	349.0	337.0	45.0
LM5112Q1SD/NOPB	WSON	NGG	6	1000	203.0	190.0	41.0
LM5112Q1SDX/NOPB	WSON	NGG	6	4500	349.0	337.0	45.0
LM5112SD	WSON	NGG	6	1000	203.0	190.0	41.0
LM5112SD/NOPB	WSON	NGG	6	1000	203.0	190.0	41.0
LM5112SDX	WSON	NGG	6	4500	349.0	337.0	45.0
LM5112SDX/NOPB	WSON	NGG	6	4500	349.0	337.0	45.0

DGN0008A

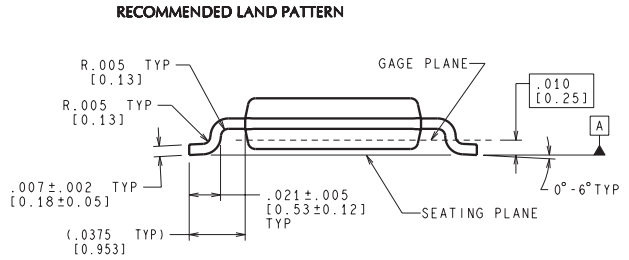
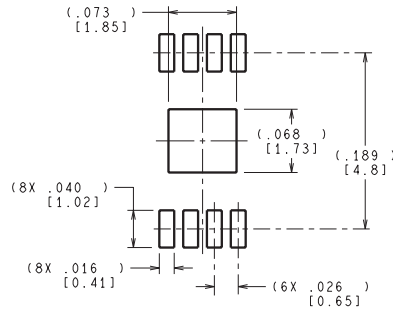
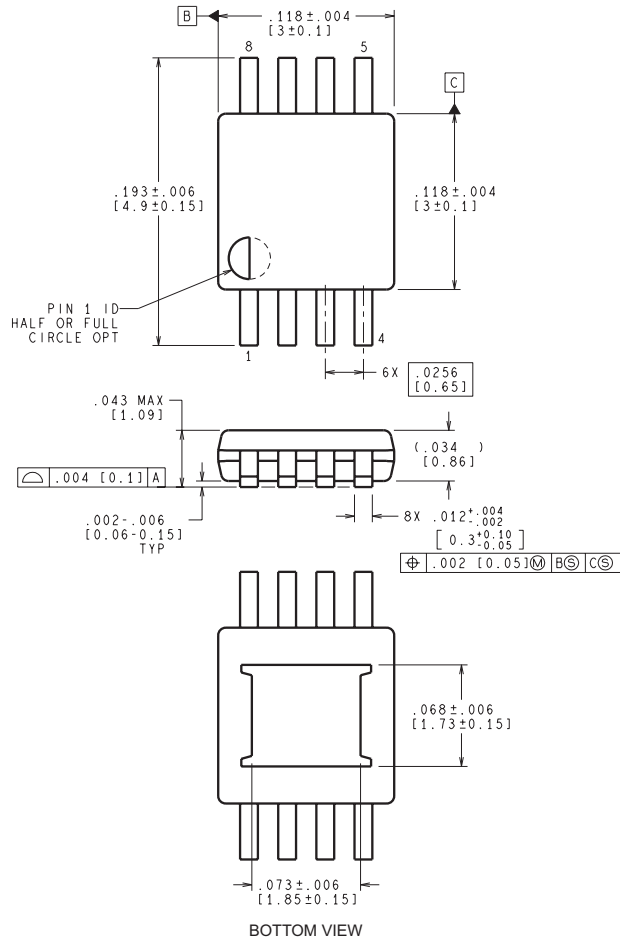

CONTROLLING DIMENSION IS INCH
VALUES IN [] ARE MILLIMETERS

MUY08A (Rev A)

NGG0006A



DIMENSIONS ARE IN MILLIMETERS
DIMENSION IN () FOR REFERENCE ONLY

RECOMMENDED LAND PATTERN

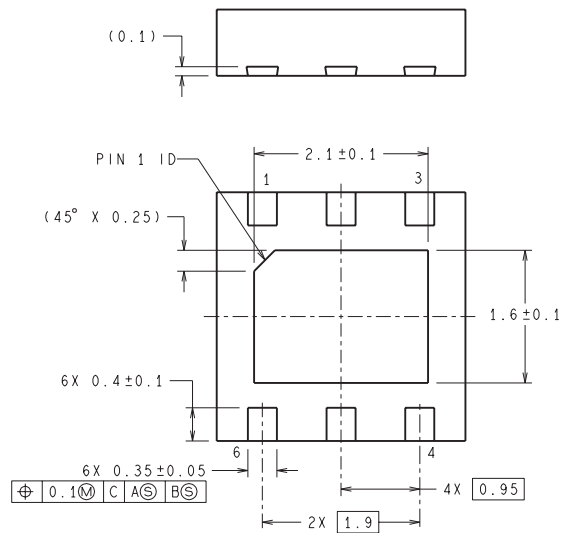
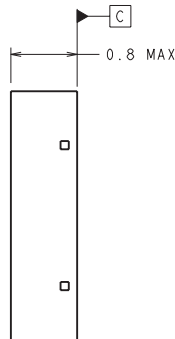
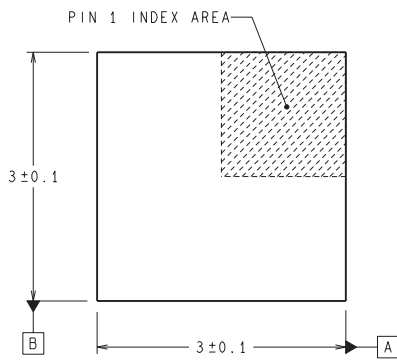

SDE06A (Rev A)

IMPORTANT NOTICE

Texas Instruments Incorporated and its subsidiaries (TI) reserve the right to make corrections, enhancements, improvements and other changes to its semiconductor products and services per JESD46, latest issue, and to discontinue any product or service per JESD48, latest issue. Buyers should obtain the latest relevant information before placing orders and should verify that such information is current and complete. All semiconductor products (also referred to herein as "components") are sold subject to TI's terms and conditions of sale supplied at the time of order acknowledgment.

TI warrants performance of its components to the specifications applicable at the time of sale, in accordance with the warranty in TI's terms and conditions of sale of semiconductor products. Testing and other quality control techniques are used to the extent TI deems necessary to support this warranty. Except where mandated by applicable law, testing of all parameters of each component is not necessarily performed.

TI assumes no liability for applications assistance or the design of Buyers' products. Buyers are responsible for their products and applications using TI components. To minimize the risks associated with Buyers' products and applications, Buyers should provide adequate design and operating safeguards.

TI does not warrant or represent that any license, either express or implied, is granted under any patent right, copyright, mask work right, or other intellectual property right relating to any combination, machine, or process in which TI components or services are used. Information published by TI regarding third-party products or services does not constitute a license to use such products or services or a warranty or endorsement thereof. Use of such information may require a license from a third party under the patents or other intellectual property of the third party, or a license from TI under the patents or other intellectual property of TI.

Reproduction of significant portions of TI information in TI data books or data sheets is permissible only if reproduction is without alteration and is accompanied by all associated warranties, conditions, limitations, and notices. TI is not responsible or liable for such altered documentation. Information of third parties may be subject to additional restrictions.

Resale of TI components or services with statements different from or beyond the parameters stated by TI for that component or service voids all express and any implied warranties for the associated TI component or service and is an unfair and deceptive business practice. TI is not responsible or liable for any such statements.

Buyer acknowledges and agrees that it is solely responsible for compliance with all legal, regulatory and safety-related requirements concerning its products, and any use of TI components in its applications, notwithstanding any applications-related information or support that may be provided by TI. Buyer represents and agrees that it has all the necessary expertise to create and implement safeguards which anticipate dangerous consequences of failures, monitor failures and their consequences, lessen the likelihood of failures that might cause harm and take appropriate remedial actions. Buyer will fully indemnify TI and its representatives against any damages arising out of the use of any TI components in safety-critical applications.

In some cases, TI components may be promoted specifically to facilitate safety-related applications. With such components, TI's goal is to help enable customers to design and create their own end-product solutions that meet applicable functional safety standards and requirements. Nonetheless, such components are subject to these terms.

No TI components are authorized for use in FDA Class III (or similar life-critical medical equipment) unless authorized officers of the parties have executed a special agreement specifically governing such use.

Only those TI components which TI has specifically designated as military grade or "enhanced plastic" are designed and intended for use in military/aerospace applications or environments. Buyer acknowledges and agrees that any military or aerospace use of TI components which have **not** been so designated is solely at the Buyer's risk, and that Buyer is solely responsible for compliance with all legal and regulatory requirements in connection with such use.

TI has specifically designated certain components as meeting ISO/TS16949 requirements, mainly for automotive use. In any case of use of non-designated products, TI will not be responsible for any failure to meet ISO/TS16949.

Products

Audio	www.ti.com/audio
Amplifiers	amplifier.ti.com
Data Converters	dataconverter.ti.com
DLP® Products	www.dlp.com
DSP	dsp.ti.com
Clocks and Timers	www.ti.com/clocks
Interface	interface.ti.com
Logic	logic.ti.com
Power Mgmt	power.ti.com
Microcontrollers	microcontroller.ti.com
RFID	www.ti-rfid.com
OMAP Applications Processors	www.ti.com/omap
Wireless Connectivity	www.ti.com/wirelessconnectivity

Applications

Automotive and Transportation	www.ti.com/automotive
Communications and Telecom	www.ti.com/communications
Computers and Peripherals	www.ti.com/computers
Consumer Electronics	www.ti.com/consumer-apps
Energy and Lighting	www.ti.com/energy
Industrial	www.ti.com/industrial
Medical	www.ti.com/medical
Security	www.ti.com/security
Space, Avionics and Defense	www.ti.com/space-avionics-defense
Video and Imaging	www.ti.com/video

TI E2E Community

e2e.ti.com