

4 TO 16-LINE DECODER/DEMULTIPLEXER

- **HIGH SPEED**
 $t_{PD} = 23 \text{ ns (TYP.)}$ at $V_{CC} = 5V$
- **LOW POWER DISSIPATION**
 $I_{CC} = 4 \mu\text{A (MAX.)}$ at $T_A = 25^\circ\text{C}$
- **HIGH NOISE IMMUNITY**
 $V_{NIH} = V_{NIL} = 28\% V_{CC}$ (MIN.)
- **OUTPUT DRIVE CAPABILITY**
 15 LSTTL LOADS
- **SYMMETRICAL OUTPUT IMPEDANCE**
 $|I_{OH}| = I_{OL} = 6 \text{ mA (MIN.)}$
- **BALANCED PROPAGATION DELAYS**
 $t_{PLH} = t_{PHL}$
- **WIDE OPERATING VOLTAGE RANGE**
 V_{CC} (OPR) = 2V to 6V
- **PIN AND FUNCTION COMPATIBLE**
 WITH 54/74LS154

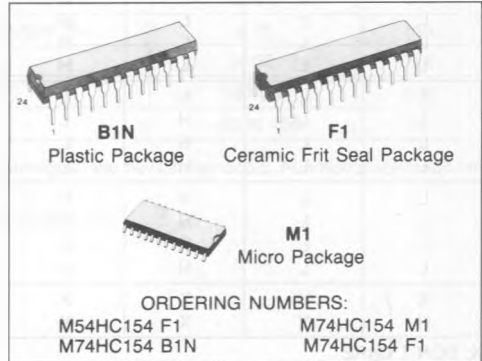

DESCRIPTION

The M54/74HC154 is a high speed CMOS 4 TO 16-LINE DECODER/DEMULTIPLEXER fabricated in silicon gate C²MOS technology. It has the same high speed performance of LSTTL combined with true CMOS low power consumption.

A binary code applied to the four inputs (A to D) provides a low level at the selected one of sixteen outputs excluding the other fifteen outputs, when both the strobe inputs, $\overline{G1}$ and $\overline{G2}$, are held low. When either strobe input is held high, the decoding function is inhibited to keep all outputs high. The strobe function makes it easy to expand the decoding lines through cascading, and simplifies the design of address decoding circuits in memory control systems.

All inputs are equipped with protection circuits against static discharge and transient excess voltage.

PIN CONNECTIONS (top view)

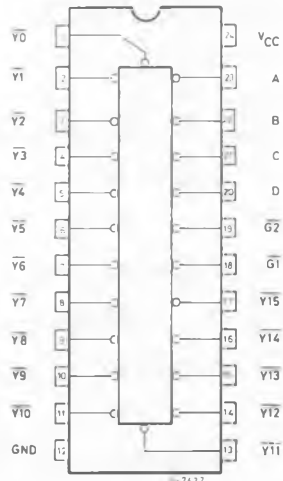

TRUTH TABLE

INPUTS						SELECTED OUTPUT (L)
\overline{G}_1	\overline{G}_2	D	C	B	A	
L	L	L	L	L	L	\overline{Y}_0
L	L	L	L	L	H	\overline{Y}_1
L	L	L	L	H	L	\overline{Y}_2
L	L	L	L	H	H	\overline{Y}_3
L	L	L	H	L	L	\overline{Y}_4
L	L	L	H	L	H	\overline{Y}_5
L	L	L	H	H	L	\overline{Y}_6
L	L	L	H	H	H	\overline{Y}_7
L	L	H	L	L	L	\overline{Y}_8
L	L	H	L	L	H	\overline{Y}_9
L	L	H	L	H	L	\overline{Y}_{10}
L	L	H	L	H	H	\overline{Y}_{11}
L	L	H	H	L	L	\overline{Y}_{12}
L	L	H	H	L	H	\overline{Y}_{13}
L	L	H	H	H	L	\overline{Y}_{14}
L	L	H	H	H	H	\overline{Y}_{15}
X	H	X	X	X	X	NONE
H	X	X	X	X	X	NONE

X: DON'T CARE

LOGIC DIAGRAM

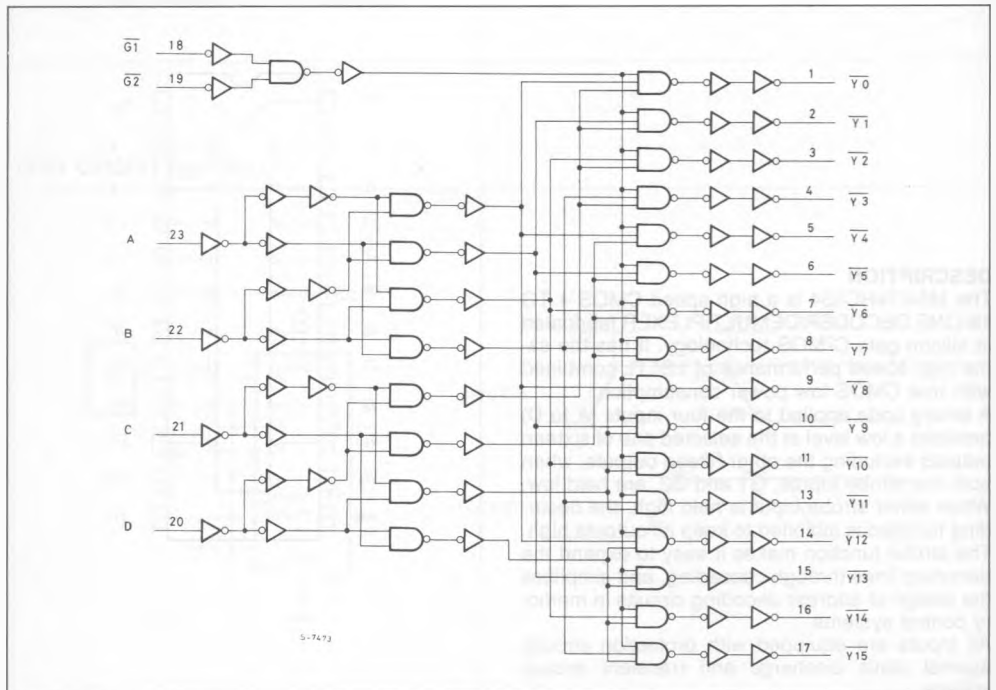

ABSOLUTE MAXIMUM RATINGS

Symbol	Parameter	Value	Unit
V_{CC}	Supply Voltage	- 0.5 to 7	V
V_I	DC Input Voltage	- 0.5 to $V_{CC} + 0.5$	V
V_O	DC Output Voltage	- 0.5 to $V_{CC} + 0.5$	V
I_{IK}	DC Input Diode Current	± 20	mA
I_{OK}	DC Output Diode Current	± 20	mA
I_O	DC Output Source Sink Current Per Output Pin	± 25	mA
I_{CC} or I_{GND}	DC V_{CC} or Ground Current	± 50	mA
P_D	Power Dissipation	500 (*)	mW
T_{stg}	Storage Temperature	- 65 to 150	$^{\circ}C$

Absolute Maximum Ratings are those values beyond which damage to the device may occur. Functional operation under these condition is not implied.

(*) 500 mW: $\cong 65^{\circ}C$ derate to 300 mW by 10 mW/ $^{\circ}C$: $65^{\circ}C$ to $85^{\circ}C$

RECOMMENDED OPERATING CONDITIONS

Symbol	Parameter	Value	Unit
V_{CC}	Supply Voltage	2 to 6	V
V_I	Input Voltage	0 to V_{CC}	V
V_O	Output Voltage	0 to V_{CC}	V
T_A	Operating Temperature 74HC Series 54HC Series	- 40 to 85 - 55 to 125	$^{\circ}C$
t_r, t_f	Input Rise and Fall Time	$V_{CC} \begin{cases} 2 \text{ V} & 0 \text{ to } 1000 \\ 4.5 \text{ V} & 0 \text{ to } 500 \\ 6 \text{ V} & 0 \text{ to } 400 \end{cases}$	ns

INPUT AND OUTPUT EQUIVALENT CIRCUIT

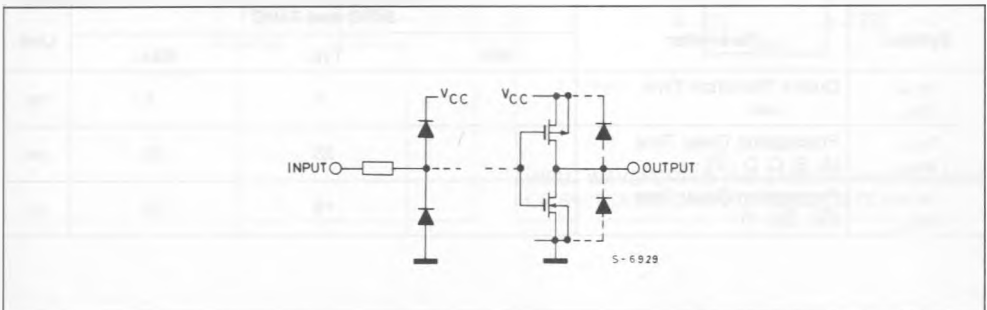

DC SPECIFICATIONS

Symbol	Parameter	V _{CC}	Test Condition	T _A = 25°C 54HC and 74HC			- 40 to 85°C 74HC		- 55 to 125°C 54HC		Unit	
				Min.	Typ.	Max.	Min.	Max.	Min.	Max.		
V _{IH}	High Level Input Voltage	2.0		1.5	—	—	1.5	—	1.5	—	V	
		4.5		3.15	—	—	3.15	—	3.15	—		
		6.0		4.2	—	—	4.2	—	4.2	—		
V _{IL}	Low Level Input Voltage	2.0		—	—	0.5	—	0.5	—	0.5	V	
		4.5		—	—	1.35	—	1.35	—	1.35		
		6.0		—	—	1.8	—	1.8	—	1.8		
V _{OH}	High Level Output Voltage	2.0	V _I	I _O	1.9	2.0	—	1.9	—	1.9	—	V
		4.5			- 20 μA	4.4	4.5	—	4.4	—	4.4	
		6.0	5.9	6.0		—	5.9	—	5.9	—		
		4.5	- 4.0 mA	4.18		4.31	—	4.13	—	4.10	—	
		6.0		- 5.2 mA	5.68	5.8	—	5.63	—	5.60	—	
V _{OL}	Low Level Output Voltage	2.0	V _{IH} or V _{IL}	20 μA	—	0	0.1	—	0.1	—	0.1	V
		4.5			—	0	0.1	—	0.1	—	0.1	
		6.0	—	0	0.1	—	0.1	—	0.1			
		4.5	4.0 mA	—	0.17	0.32	—	0.37	—	0.40		
		6.0		5.2 mA	—	0.18	0.32	—	0.37	—	0.40	
I _I	Input Leakage Current	6.0	V _I = V _{CC} or GND		—	—	±0.1	—	±1	—	±1	μA
I _{CC}	Quiescent Supply Current	6.0	V _I = V _{CC} or GND		—	—	4	—	40	—	80	μA

AC ELECTRICAL CHARACTERISTICS (V_{CC} = 5V, T_A = 25°C, C_L = 15pF, Input t_r = t_f = 6ns)

Symbol	Parameter	54HC and 74HC			Unit
		Min.	Typ.	Max.	
t _{TLH} t _{THL}	Output Transition Time		4	8	ns
t _{PLH} t _{PHL}	Propagation Delay Time (A, B, C, D - \bar{Y})		23	36	ns
t _{PLH} t _{PHL}	Propagation Delay Time ($\bar{G}1, \bar{G}2, Y$)		19	30	ns

AC ELECTRICAL CHARACTERISTICS ($C_L = 50\text{pF}$, Input $t_r = t_f = 6\text{ns}$)

Symbol	Parameter	V_{CC}	Test Condition	$T_A = 25^\circ\text{C}$ 54HC and 74HC			-40 to 85°C 74HC		-55 to 125°C 54HC		Unit
				Min.	Typ.	Max.	Min.	Max.	Min.	Max.	
t_{TLH} T_{THL}	Output Transition Time	2.0 4.5 6.0		— — —	30 8 7	75 15 13	— — —	95 19 16	— — —	110 22 19	ns
t_{PLH} t_{PHL}	Propagation Delay Time A, B, C, D-Y	2.0 4.5 6.0		— — —	104 26 22	200 40 34	— — —	250 50 43	— — —	300 60 51	ns
t_{PLH} t_{PHL}	Propagation Delay Time (\bar{G}_1 , \bar{G}_2 -Y)	2.0 4.5 6.0		— — —	88 22 19	175 35 30	— — —	220 44 37	— — —	265 53 45	ns
C_{IN}	Input Capacitance			—	5	10	—	10	—	10	pF
$C_{PD} (*)$	Power Dissipation Capacitance			—	68	—	—	—	—	—	pF

Note (*) C_{PD} is defined as the value of the IC's internal equivalent capacitance which is calculated from the operating current consumption without load (refer to Test circuit).

Average operating current can be obtained by equation hereunder.

$$I_{CC(\text{opr})} = C_{PD} \cdot V_{CC} \cdot f_{IN} + I_{CC}$$

SWITCHING CHARACTERISTICS TEST CIRCUIT

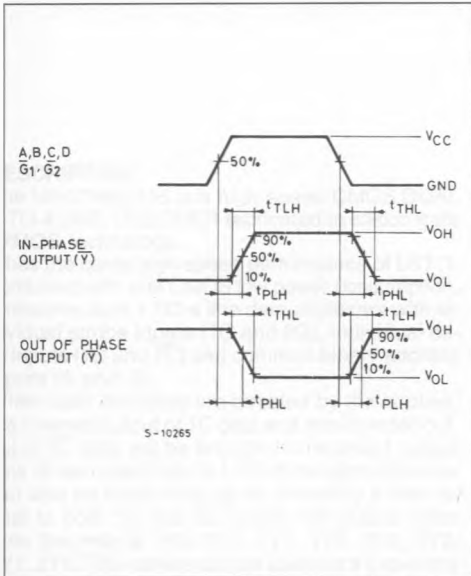
TEST CIRCUIT I_{CC} (Opr.)