

HC257 QUAD 2-CHANNEL MULTIPLEXER (3-STATE) HC258 QUAD 2-CHANNEL MULTIPLEXER (3-STATE, INVERTING)

- **HIGH SPEED**
 $t_{PD} = 12 \text{ ns (TYP.) at } V_{CC} = 5\text{V}$
- **LOW POWER DISSIPATION**
 $I_{CC} = 4 \mu\text{A (MAX.) at } T_A = 25^\circ\text{C}$
- **HIGH NOISE IMMUNITY**
 $V_{NIH} = V_{NIL} = 28\% V_{CC} \text{ (MIN.)}$
- **OUTPUT DRIVE CAPABILITY**
 15 LSTTL LOADS
- **SYMMETRICAL OUTPUT IMPEDANCE**
 $|I_{OH}| = I_{OL} = 6 \text{ mA (MIN.)}$
- **BALANCED PROPAGATION DELAYS**
 $t_{PLH} = t_{PHL}$
- **WIDE OPERATING VOLTAGE RANGE**
 $V_{CC} \text{ (OPR)} = 2\text{V to } 6\text{V}$
- **PIN AND FUNCTION COMPATIBLE**
 WITH 54/74LS257/258

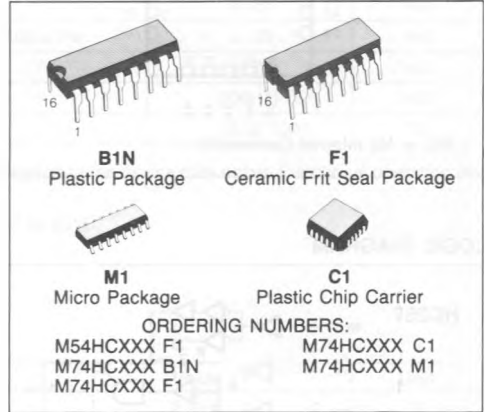

DESCRIPTION

The M54/74HC257 and the M54/74HC258 are high speed CMOS MULTIPLEXERS fabricated with silicon gate C²MOS technology.

They have the same high speed performance of LSTTL combined with true CMOS low power consumption.

These IC's are composed of an independent 2-channel multiplexer with common SELECT and ENABLE INPUT.

The M54/74HC258 is an inverting multiplexer while the M54/74HC257 is a non-inverting multiplexer. When the ENABLE INPUT is held "High", outputs of both IC's become high-impedance state. If SELECT INPUT is held "Low", "A" data is selected, when SELECT INPUT is high "H", "B" data is chosen.

All inputs are equipped with protection circuits against static discharge and transient excess voltage.

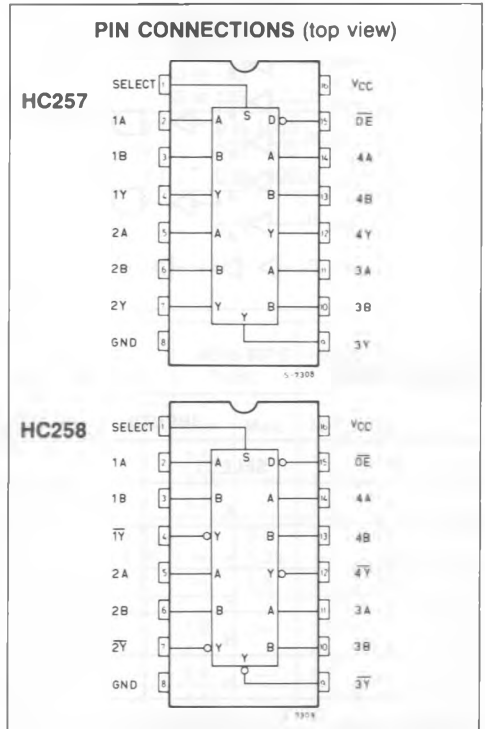

CHIP CARRIER

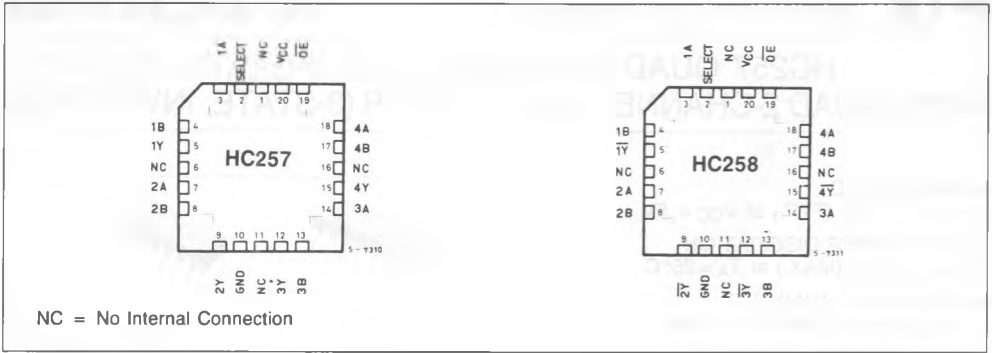

LOGIC DIAGRAM

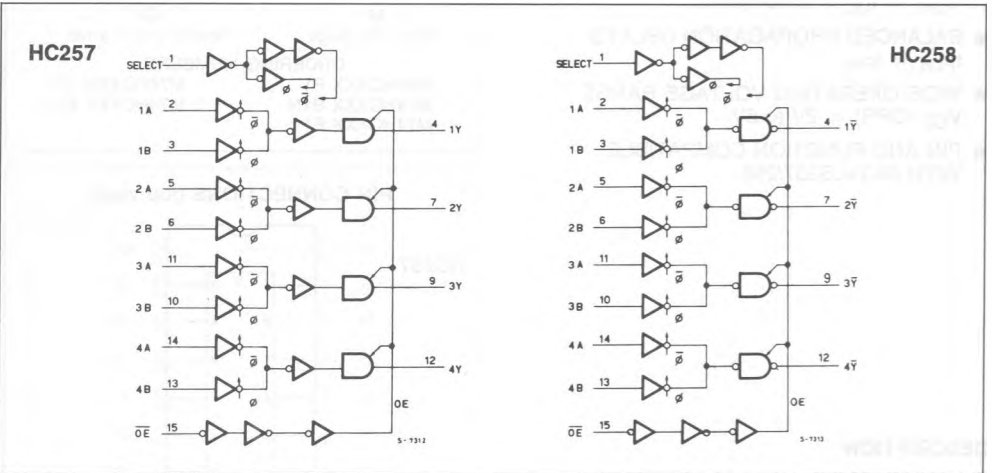

TRUTH TABLE

INPUTS				OUTPUTS	
\overline{OE}	SELECT	A	B	Y (257)	\overline{Y} (258)
H	X	X	X	Z	Z
L	L	L	X	L	H
L	L	H	X	H	L
L	H	X	L	L	H
L	H	X	H	H	L

X: DON'T CARE Z: HIGH IMPEDANCE

ABSOLUTE MAXIMUM RATINGS

Symbol	Parameter	Value	Unit
V_{CC}	Supply Voltage	- 0.5 to 7	V
V_I	DC Input Voltage	- 0.5 to $V_{CC} + 0.5$	V
V_O	DC Output Voltage	- 0.5 to $V_{CC} + 0.5$	V
I_{IK}	DC Input Diode Current	± 20	mA
I_{OK}	DC Output Diode Current	± 20	mA
I_O	DC Output Source Sink Current Per Output Pin	± 35	mA
I_{CC} or I_{GND}	DC V_{CC} or Ground Current	± 70	mA
P_D	Power Dissipation	500 (*)	mW
T_{stg}	Storage Temperature	- 65 to 150	$^{\circ}C$

Absolute Maximum Ratings are those values beyond which damage to the device may occur. Functional operation under these condition is not implied.

(*) 500 mW: \equiv 65 $^{\circ}C$ derate to 300 mW by 10 mW/ $^{\circ}C$: 65 $^{\circ}C$ to 85 $^{\circ}C$.

RECOMMENDED OPERATING CONDITIONS

Symbol	Parameter	Value	Unit	
V_{CC}	Supply Voltage	2 to 6	V	
V_I	Input Voltage	0 to V_{CC}	V	
V_O	Output Voltage	0 to V_{CC}	V	
T_A	Operating Temperature	74HC Series 54HC Series	- 40 to 85 - 55 to 125	$^{\circ}C$
t_r, t_f	Input Rise and Fall Time	V_{CC} $\begin{cases} 2 \text{ V} & 0 \text{ to } 1000 \\ 4.5 \text{ V} & 0 \text{ to } 500 \\ 6 \text{ V} & 0 \text{ to } 400 \end{cases}$	ns	

DC SPECIFICATIONS

Symbol	Parameter	V_{CC}	Test Condition	$T_A = 25^{\circ}C$ 54HC and 74HC			$- 40 \text{ to } 85^{\circ}C$ 74HC		$- 55 \text{ to } 125^{\circ}C$ 54HC		Unit	
				Min.	Typ.	Max.	Min.	Max.	Min.	Max.		
V_{IH}	High Level Input Voltage	2.0		1.5	—	—	1.5	—	1.5	—	V	
		4.5		3.15	—	—	3.15	—	3.15	—		
		6.0		4.2	—	—	4.2	—	4.2	—		
V_{IL}	Low Level Input Voltage	2.0		—	—	0.5	—	0.5	—	0.5	V	
		4.5		—	—	1.35	—	1.35	—	1.35		
		6.0		—	—	1.8	—	1.8	—	1.8		
V_{OH}	High Level Output Voltage	2.0	V_I	I_O	1.9	2.0	—	1.9	—	1.9	—	V
		4.5			V_{IH} or V_{IL}	- 20 μA	4.4	4.5	—	4.4	—	
		6.0	- 4.0 mA - 5.2 mA	5.9		6.0	—	5.9	—	5.9	—	
		4.5		4.18	4.31	—	4.13	—	4.10	—		
6.0	5.68	5.8	—	5.63	—	5.60	—					

DC SPECIFICATIONS (Continued)

Symbol	Parameter	V _{CC}	Test Condition		T _A = 25°C			- 40 to 85°C		- 55 to 125°C		Unit	
					54HC and 74HC			74HC		54HC			
					Min.	Typ.	Max.	Min.	Max.	Min.	Max.		
V _{OL}	Low Level Output Voltage	2.0	V _{IH} or V _{IL}	20 μA	—	0.0	0.1	—	0.1	—	0.1	V	
		4.5			—	0.0	0.1	—	0.1				
		6.0			—	0.0	0.1	—	0.1				
		4.5	V _{IH} or V _{IL}	4.0 mA	—	0.17	0.26	—	0.33	—	0.40		
		6.0			V _{IH} or V _{IL}	5.2 mA	—	0.18	0.26	—	0.33		—
I _I	Input Leakage Current	6.0	V _I = V _{CC} or GND				—	—	±0.1	—	±1.0	—	±1.0
I _{OZ}	3-State Output Off-State Current	6.0	V _I = V _{IH} or V _{IL} V _O = V _{CC} or GND		—	—	±0.5	—	±5	—	±10	μA	
I _{CC}	Quiescent Supply Current	6.0	V _I = V _{CC} or GND		—	—	4	—	40	—	80	μA	

AC ELECTRICAL CHARACTERISTICS (C_L = 50pF, Input t_r = t_f = 6ns)

Symbol	Parameter	V _{CC}	Test Condition		T _A = 25°C			- 40 to 85°C		- 55 to 125°C		Unit	
					54HC and 74HC			74HC		54HC			
					Min.	Typ.	Max.	Min.	Max.	Min.	Max.		
t _{TLH} t _{THL}	Output Transition Time	2.0			—	23	60	—	75	—	90	ns	
		4.5			—	7	12	—	15	—	18		
		6.0			—	6	10	—	13	—	15		
t _{PLH} t _{PHL}	Propagation Delay Time HC257 A, B - Y	2.0			—	50	100	—	125	—	150	ns	
		4.5			—	15	20	—	25	—	30		
		6.0			—	13	17	—	21	—	26		
t _{PLH} t _{PHL}	Propagation Delay Time HC257 (SELECT - Y)	2.0			—	80	160	—	200	—	240	ns	
		4.5			—	22	32	—	40	—	48		
		6.0			—	19	17	—	34	—	41		
t _{PLH} t _{PHL}	Propagation Delay Time HC258 (A, B - Y)	2.0			—	50	100	—	125	—	150	ns	
		4.5			—	15	20	—	25	—	30		
		6.0			—	13	27	—	21	—	26		
t _{PLH} t _{PHL}	Propagation Delay Time HC258 SELECT - Y	2.0			—	80	160	—	200	—	240	ns	
		4.5			—	22	32	—	40	—	48		
		6.0			—	19	27	—	34	—	41		
t _{PZL} t _{PZH}	Output Enable Time	2.0	R _L = 1kΩ		—	60	110	—	140	—	165	ns	
		4.5			—	15	22	—	28	—	33		
		6.0			—	13	19	—	24	—	28		

AC ELECTRICAL CHARACTERISTICS (Continued)

Symbol	Parameter	V _{CC}	Test Condition	T _A = 25°C 54HC and 74HC			- 40 to 85°C 74HC		- 55 to 125°C 54HC		Unit
				Min.	Typ.	Max.	Min.	Max.	Min.	Max.	
t _{PLZ}	Output Disable	2.0	R _L = 1kΩ	—	44	140	—	175	—	210	ns
t _{PHZ}	Time	4.5		—	21	28	—	35	—	42	
		6.0		—	20	24	—	30	—	36	
C _{IN}	Input Capacitance			—	5	10	—	10	—	10	pF
C _{OUT}	Output Capacitance			—	60	—	—	—	—	—	
C _{PD} (*)	Power Dissipation Capacitance		M54/74HC257	—	60	—	—	—	—	—	pF
			M54/74HC258	—	59	—	—	—	—	—	

Note (*) C_{PD} is defined as the value of the IC's internal equivalent capacitance which is calculated from the operating current consumption without load. (Refer to Test Circuit). Average operating current can be obtained by the following equation. I_{CC(opr)} = C_{PD} · V_{CC} · f_{IN} + I_{CC}/4 (per Channel)

SWITCHING CHARACTERISTICS TEST WAVEFORM

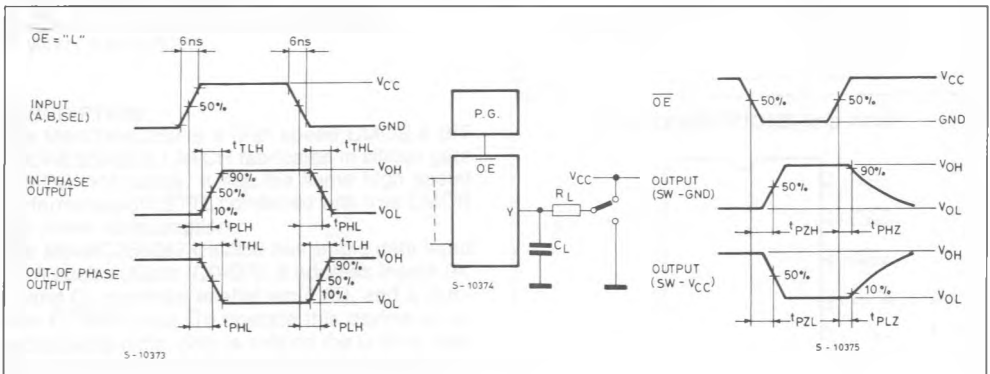
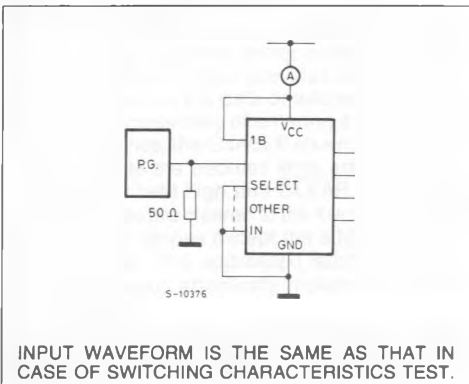
TEST CIRCUIT I_{CC} (Opr.)C_{PD} CALCULATION

C_{PD} is to be calculated with the following formula by using the measured value of I_{CC} (Opr.) in the test circuit opposite.

$$C_{PD} = \frac{I_{CC(opr)}}{f_{IN} \cdot V_{CC}}$$