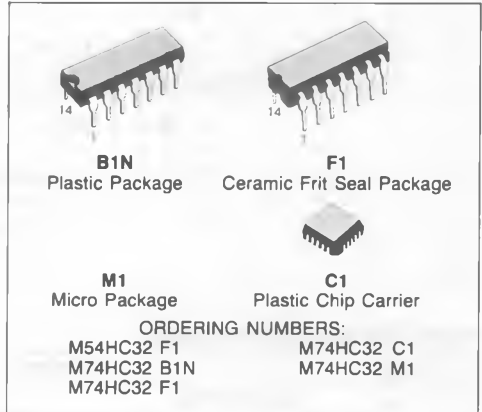
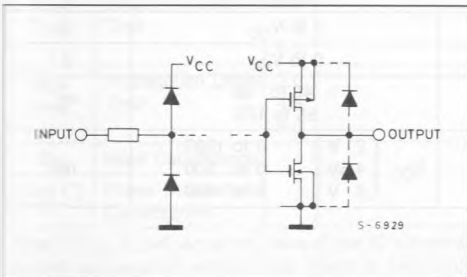
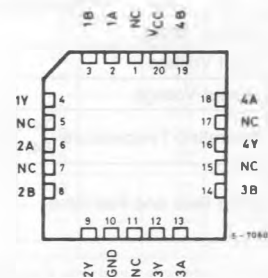
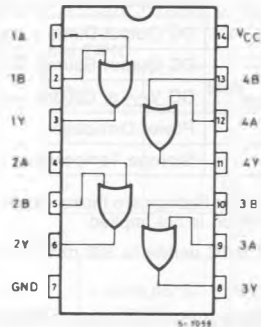

QUAD 2-INPUT OR GATE

- **HIGH SPEED**
 $t_{PD} = 8 \text{ ns (TYP.) at } V_{CC} = 5V$
- **LOW POWER DISSIPATION**
 $I_{CC} = 1 \mu A \text{ (MAX.) at } T_A = 25^\circ C$
- **HIGH NOISE IMMUNITY**
 $V_{NIH} = V_{NIL} = 28\% V_{CC} \text{ (MIN.)}$
- **OUTPUT DRIVE CAPABILITY**
 10 LSTTL LOADS
- **SYMMETRICAL OUTPUT IMPEDANCE**
 $|I_{OH}| = I_{OL} = 4 \text{ mA (MIN.)}$
- **BALANCED PROPAGATION DELAYS**
 $t_{PLH} = t_{PHL}$
- **WIDE OPERATING VOLTAGE RANGE**
 $V_{CC} \text{ (OPR)} = 2V \text{ to } 6V$
- **PIN AND FUNCTION COMPATIBLE**
 WITH 54/74LS32

DESCRIPTION

The M54/74HC32 is a high speed CMOS 2-INPUT OR GATE fabricated in silicon gate CMOS technology. It has the same high speed performance of LSTTL combined with true CMOS low power consumption. It achieves the high speed operation similar to equivalent LSTTL while maintaining the CMOS low power dissipation. The internal circuit is composed of 2 stages including buffered output, which gives high noise immunity and a stable output. All inputs are equipped with protection circuits against static discharge and transient excess voltage.

INPUT AND OUTPUT EQUIVALENT CIRCUIT

PIN CONNECTIONS (top view)

NC =
 No Internal
 Connection

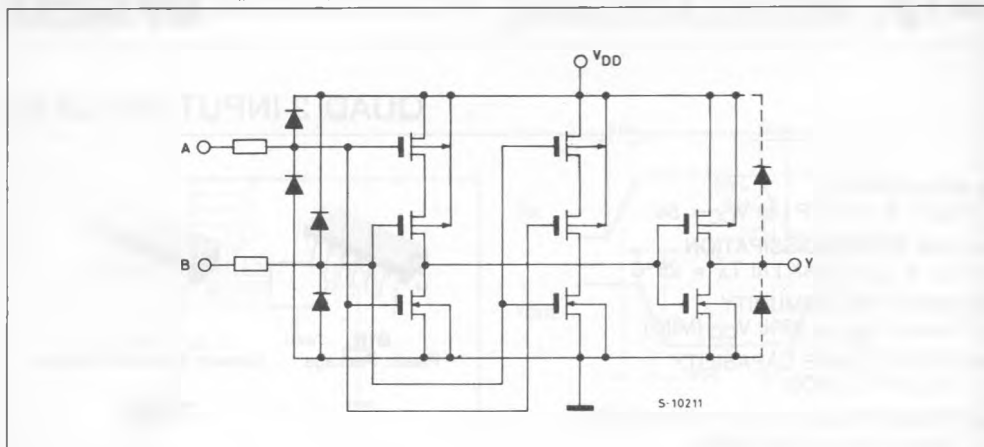
CIRCUIT SCHEMATIC (per Gate)



ABSOLUTE MAXIMUM RATINGS

Symbol	Parameter	Value	Unit
V_{CC}	Supply Voltage	-0.5 to 7	V
V_I	DC Input Voltage	-0.5 to $V_{CC} + 0.5$	V
V_O	DC Output Voltage	-0.5 to $V_{CC} + 0.5$	V
I_{IK}	DC Input Diode Current	± 20	mA
I_{OK}	DC Output Diode Current	± 20	mA
I_O	DC Output Source Sink Current Per Output Pin	± 25	mA
I_{CC} or I_{GND}	DC V_{CC} or Ground Current	± 50	mA
P_D	Power Dissipation	500 (*)	mW
T_{stg}	Storage Temperature	-65 to 150	$^{\circ}C$

Absolute Maximum Ratings are those values beyond which damage to the device may occur. Functional operation under these conditions is not implied.

(*) 500 mW: $\cong 65^{\circ}C$ derate to 300 mW by 10 mW/ $^{\circ}C$: $65^{\circ}C$ to $85^{\circ}C$

RECOMMENDED OPERATING CONDITIONS

Symbol	Parameter	Value	Unit
V_{CC}	Supply Voltage	2 to 6	V
V_I	Input Voltage	0 to V_{CC}	V
V_O	Output Voltage	0 to V_{CC}	V
T_A	Operating Temperature	74HC Series 54HC Series	$^{\circ}C$
t_r, t_f	Input Rise and Fall Time	V_{CC} $\begin{cases} 2 \text{ V} & 0 \text{ to } 1000 \\ 4.5 \text{ V} & 0 \text{ to } 500 \\ 6 \text{ V} & 0 \text{ to } 400 \end{cases}$	ns

DC SPECIFICATIONS

Symbol	Parameter	V _{CC}	Test Condition		T _A = 25°C 54HC and 74HC			- 40 to 85°C 74HC		- 55 to 125°C 54HC		Unit		
					Min.	Typ.	Max.	Min.	Max.	Min.	Max.			
V _{IH}	High Level Input Voltage	2.0			1.5	—	—	1.5	—	1.5	—	V		
		4.5			3.15	—	—	3.15	—	3.15	—			
		6.0			4.2	—	—	4.2	—	4.2	—			
V _{IL}	Low Level Input Voltage	2.0			—	—	0.5	—	0.5	—	0.5	V		
		4.5			—	—	1.35	—	1.35	—	1.35			
		6.0			—	—	1.8	—	1.8	—	1.8			
V _{OH}	High Level Output Voltage	2.0	V _I	I _O	1.9	2.0	—	1.9	—	1.9	—	V		
		4.5			V _{IH} or V _{IL}	- 20 μA	4.4	4.5	—	4.4	—		4.4	—
		6.0			- 4.0 mA - 5.2 mA	5.9	6.0	—	5.9	—	5.9		—	
		4.5				4.18	4.31	—	4.13	—	4.10		—	
6.0	5.68	5.8	—	5.63	—	5.60	—							
V _{OL}	Low Level Output Voltage	2.0	V _{IH} or V _{IL}	20 μA	—	0	0.1	—	0.1	—	0.1	V		
		4.5			—	0	0.1	—	0.1	—	0.1			
		6.0			—	0	0.1	—	0.1	—	0.1			
		4.5			4.0 mA	—	0.17	0.26	—	0.33	—		0.40	
6.0	5.2 mA	—	0.18	0.26	—	0.33	—	0.40						
I _I	Input Leakage Current	6.0	V _I = V _{CC} or GND		—	—	±0.1	—	±1	—	±1	μA		
I _{CC}	Quiescent Supply Current	6.0	V _I = V _{CC} or GND		—	—	1	—	10	—	20	μA		

AC ELECTRICAL CHARACTERISTICS (V_{CC} = 5V, T_A = 25°C, C_L = 15pF, Input t_r = t_f = 6ns)

Symbol	Parameter	54HC and 74HC			Unit
		Min.	Typ.	Max.	
t _{TLH} t _{THL}	Output Transition Time		4	8	ns
t _{PLH} t _{PHL}	Propagation Delay Time		9	15	ns

AC ELECTRICAL CHARACTERISTICS (C_L = 50pF, Input t_r = t_f = 6ns)

Symbol	Parameter	V _{CC}	Test Condition		T _A = 25°C 54HC and 74HC			- 40 to 85°C 74HC		- 55 to 125°C 54HC		Unit
					Min.	Typ.	Max.	Min.	Max.	Min.	Max.	
t _{TLH} T _{THL}	Output Transition Time	2.0			—	30	75	—	95	—	110	ns
		4.5			—	8	15	—	19	—	22	
		6.0			—	7	13	—	16	—	19	
t _{PLH} t _{PHL}	Propagation Delay Time	2.0			—	40	90	—	115	—	135	ns
		4.5			—	10	18	—	23	—	27	
		6.0			—	9	15	—	20	—	23	
C _{IN}	Input Capacitance				—	5	10	—	10	—	10	pF
C _{PD} (*)	Power Dissipation Capacitance				—	23	—	—	—	—	—	pF

Note (*) C_{PD} is defined as the value of the IC's internal equivalent capacitance which is calculated from the operating current consumption without load. (Refer to Test Circuit)

SWITCHING CHARACTERISTICS TEST CIRCUIT

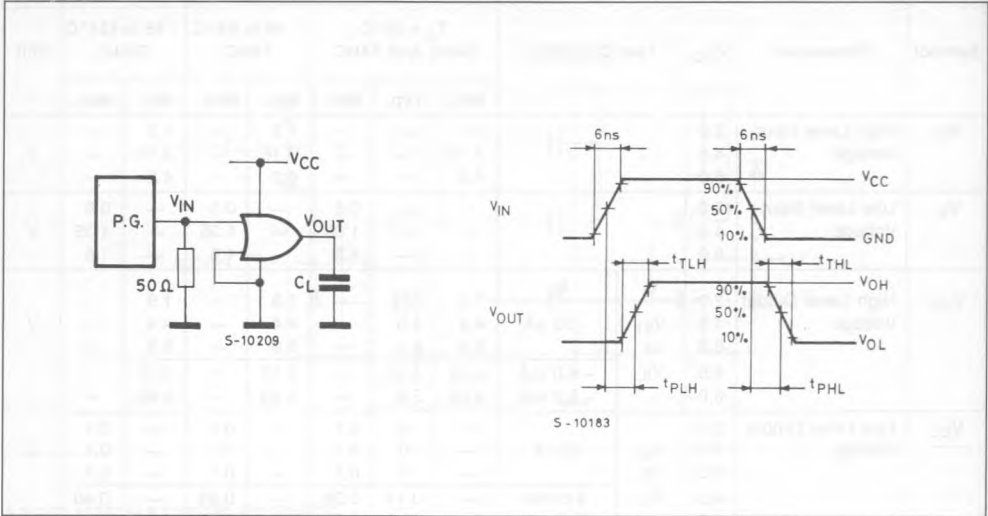

TEST CIRCUIT I_{CC} (Opr.)

