

MAXIM

MAX1232 Microprocessor Monitor

MAX1232

General Description

The MAX1232 microprocessor (μ P) supervisory circuit provides μ P "housekeeping" and power-supply supervision functions while consuming only 1/10th the power of the DS1232. The MAX1232 enhances circuit reliability in μ P systems by monitoring the power supply, monitoring software execution, and providing a debounced manual reset input. The MAX1232 is a plug-in upgrade of the Dallas DS1232.

A reset pulse of at least 250ms duration is supplied on power-up, power-down, and low-voltage brown-out conditions (5% or 10% supply tolerances can be selected digitally). Also featured is a debounced manual reset input that forces the reset outputs to their active states for a minimum of 250ms. A digitally-programmable watchdog timer monitors software execution and can be programmed for timeout settings of 150ms, 600ms, or 1.2sec. The MAX1232 requires no external components.

Applications

Computers
 Controllers
 Intelligent Instruments
 Automotive Systems
 Critical μ P Power Monitoring

Block Diagram

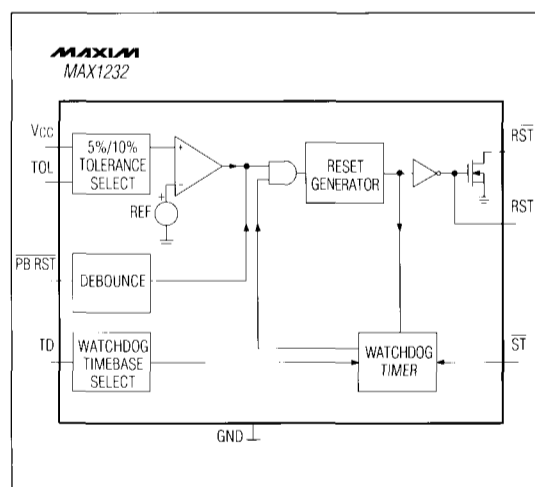

Features

- ◆ Consumes 1/10th the Power of the DS1232
- ◆ Precision Voltage Monitor - Adjustable +4.5V or +4.75V
- ◆ Power OK/Reset Pulse Width - 250ms Min
- ◆ No External Components
- ◆ Adjustable Watchdog Timer - 150ms, 600ms, or 1.2sec
- ◆ Debounced Manual Reset Input for External Override
- ◆ Available in 8-pin DIP/Small Outline and 16-pin Wide Small Outline Packages

Ordering Information

PART	TEMP. RANGE	PIN-PACKAGE
MAX1232CPA	0°C to +70°C	8 Plastic DIP
MAX1232CSA	0°C to +70°C	8 SO
MAX1232CWE	0°C to +70°C	16 Wide SO
MAX1232C/D	0°C to +70°C	Dice*
MAX1232EPA	-40°C to +85°C	8 Plastic DIP
MAX1232ESA	-40°C to +85°C	8 SO
MAX1232EWE	-40°C to +85°C	16 Wide SO
MAX1232MJA	-55°C to +125°C	8 CERDIP

* Contact factory for dice specifications.

Pin Configuration

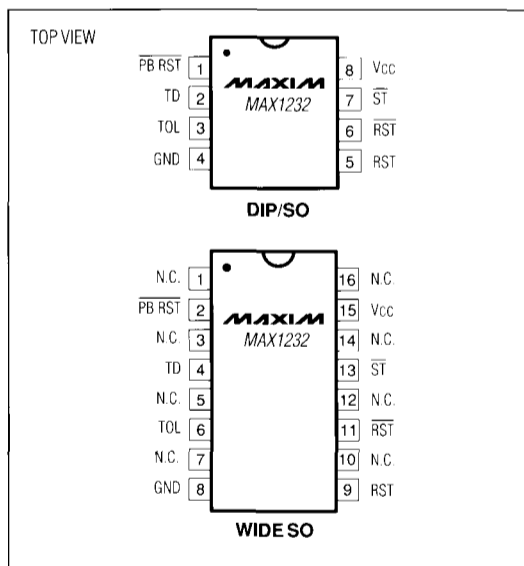

MAXIM

Maxim Integrated Products 1

Call toll free 1-800-998-8800 for free samples or literature.

MAX1232 Microprocessor Monitor

ABSOLUTE MAXIMUM RATINGS

Voltage on any pin (with respect to GND)	-1V to +7V	Storage Temperature Range	-65°C to +160°C
Operating Temperature Ranges:		Lead Temperature (Soldering, 10 sec.)	+300°C
MAX1232C	0°C to +70°C		
MAX1232E	-40°C to +85°C		
MAX1232M	-55°C to +125°C		

Stresses beyond those listed under "Absolute Maximum Ratings" may cause permanent damage to the device. These are stress ratings only, and functional operation of the device at these or any other conditions beyond those indicated in the operational sections of the specifications is not implied. Exposure to absolute maximum rating conditions for extended periods may affect device reliability.

RECOMMENDED D.C. OPERATING CONDITIONS

(TA = TMIN to TMAX)

PARAMETER	SYMBOL	CONDITIONS	MIN	TYP	MAX	UNITS
Supply Voltage	VCC		4.5	5.0	5.5	V
ST and PB RST Input High Level (Note 1)	VIH		2.0		VCC + 0.3	V
ST and PB RST Input Low Level	VIL		-0.3		+0.8	V

D.C. ELECTRICAL CHARACTERISTICS

(TA = TMIN to TMAX; VCC = +4.5V to +5.5V)

PARAMETER	SYMBOL	CONDITIONS	MIN	TYP	MAX	UNITS
Input Leakage ST, TOL	IIL		-1.0		+1.0	μA
Output Current RST	IOH	VOH = 2.4V	-1.0	-12		mA
Output Current RST, RST	IOL	VOL = 0.4V	2.0	10		mA
Operating Current (Note 2)	ICC			50	200	μA
VCC 5% Trip Point (Note 3)	VCCTP	TOL = GND	4.50	4.62	4.74	V
VCC 10% Trip Point (Note 3)	VCCTP	TOL = VCC	4.25	4.37	4.49	V

MAX1232 Microprocessor Monitor

MAX1232

CAPACITANCE (Note 4)

(TA = +25°C)

PARAMETER	SYMBOL	CONDITIONS	MIN	TYP	MAX	UNITS
Input Capacitance ST, TOL	CIN				5	pF
Output Capacitance RST, RST	COU				7	pF

A.C. ELECTRICAL CHARACTERISTICS

(TA = TMIN to TMAX; VCC = +5V to ±10%)

PARAMETER	SYMBOL	CONDITIONS	MIN	TYP	MAX	UNITS
PB RST (Note 5)	tpB	Figure 3	20			ms
PB RST Delay	tpBD	Figure 3	1	4	20	ms
Reset Active Time	trST		250	610	1000	ms
ST Pulse Width	tST	Figure 4	75			ns
ST Timeout Period	tTD	Figure 4				
		TD pin = 0V	62.5	150	250	ms
		TD pin = open	250	600	1000	
TD pin = VCC	500	1200	2000			
VCC Fall Time (Note 4)	tF	Figure 5	10			μs
VCC Rise Time (Note 4)	tR	Figure 6	0			μs
VCC Detect to RST High and RST Low	trPD	Figure 7, VCC falling			100	ns
VCC Detect to RST Low and RST Open (Note 6)	trPU	Figure 8, VCC rising	250	610	1000	ms

Note 1: PB RST is internally pulled up to VCC with an internal impedance of typically 40kΩ.

Note 2: Measured with outputs open.

Note 3: All voltages referenced to GND.

Note 4: Guaranteed by design.

Note 5: PB RST must be held low for a minimum of 20ms to guarantee a reset.

Note 6: tr = 5μs.

MAX1232 Microprocessor Monitor

Pin Description

NAME	FUNCTION
PB $\overline{\text{RST}}$	Pushbutton Reset Input. A debounced active-low input that ignores pulses less than 1ms in duration and is guaranteed to recognize inputs of 20ms or greater.
TD	Time Delay Set. The watchdog timebase select input ($t_{\text{TD}} = 150\text{ms}$ for TD = 0V, $t_{\text{TD}} = 600\text{ms}$ for TD = open, $t_{\text{TD}} = 1.2\text{sec}$ for TD = VCC).
TOL	Tolerance Input. Connect to GND for 5% tolerance or to VCC for 10% tolerance.
GND	Ground
RST	Reset Output (Active High) - goes active: 1. If VCC falls below the selected reset voltage threshold 2. If PB $\overline{\text{RST}}$ is forced low 3. If $\overline{\text{ST}}$ is not strobed within the minimum timeout period 4. During power-up
$\overline{\text{RST}}$	Reset Output (Active Low, Open Drain) - see RST.
$\overline{\text{ST}}$	Strobe Input. Input for watchdog timer.
VCC	The +5V Power-Supply Input
N.C.	No Connect

Detailed Description

Power Monitor

A voltage detector monitors VCC and holds the reset outputs (RST and $\overline{\text{RST}}$) in their active states whenever VCC is below the selected 5% or 10% tolerance (4.62V or 4.37V typically). To select the 5% level, connect TOL to ground. To select the 10% level, connect TOL to VCC. The reset outputs will remain in their active states until VCC has been continuously in-tolerance for a minimum of 250ms (the reset active time) to allow the power supply and μP to stabilize.

The RST output both sinks and sources current, while the $\overline{\text{RST}}$ output, an open-drain MOSFET, sinks current only and must be pulled high.

Pushbutton Reset Input

The MAX1232's debounced manual reset input (PB $\overline{\text{RST}}$) manually forces the reset outputs into their active states. The reset outputs go active after PB $\overline{\text{RST}}$ has been held low for a time t_{PBD} , the pushbutton reset delay time. The reset outputs remain in their active states for a minimum of 250ms after PB $\overline{\text{RST}}$ rises above V_{IH} (Figure 3).

A mechanical pushbutton or an active logic signal can drive the PB $\overline{\text{RST}}$ input. The debounced input ignores input pulses less than 1ms and is guaranteed to recognize pulses of 20ms or greater. The PB $\overline{\text{RST}}$ input has an internal pull-up to VCC of about 100 μA ; therefore, an external pull-up resistor is not necessary.

Watchdog Timer

The μP drives the $\overline{\text{ST}}$ input with an Input/Output (I/O) line. The μP must toggle the $\overline{\text{ST}}$ input within a set period (as determined by TD) to verify proper software execution. If a hardware or software failure keeps $\overline{\text{ST}}$ from toggling within the minimum timeout period - $\overline{\text{ST}}$ is activated only by falling edges (a high-to-low transition) - the MAX1232 reset outputs are forced to their active states for 250ms (Figure 2). This typically initiates the μP 's power-up routine. If the interruption continues, new reset pulses are generated each timeout period until $\overline{\text{ST}}$ is strobed. The timeout period is determined by the TD input connection. This timeout period is typically 150ms with TD connected to GND, 600ms with TD floating, or 1200ms with TD connected to VCC.

The software routine that strobes $\overline{\text{ST}}$ is critical. The code must be in a section of software that executes frequently enough so the time between toggles is less than the watchdog timeout period. One common technique controls the μP I/O line from two sections of the program. The software might set the I/O line high while operating in the foreground mode and set it low while in the background or interrupt mode. If both modes do not execute correctly, the watchdog timer issues reset pulses.

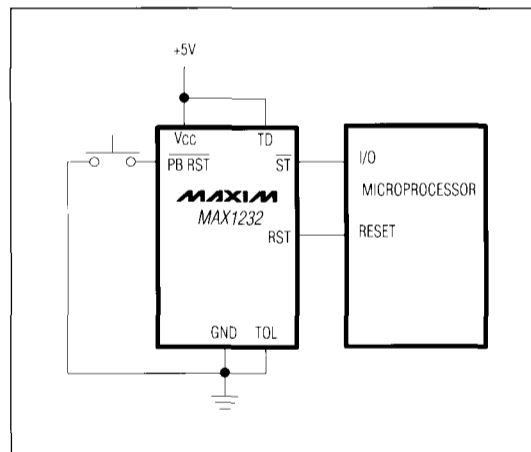

Figure 1. Pushbutton Reset

MAX1232 Microprocessor Monitor

MAX1232

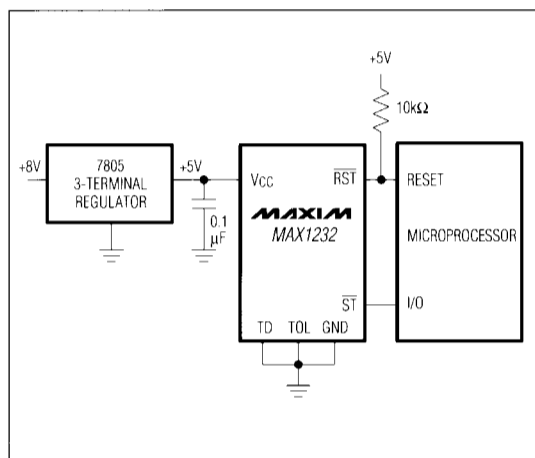

Figure 2. Watchdog Timer

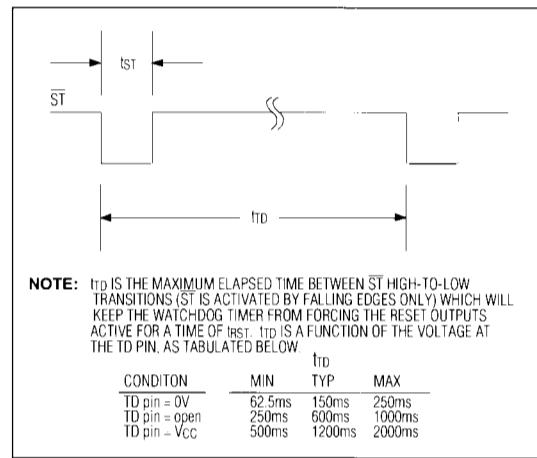

Figure 4. Watchdog Strobe Input

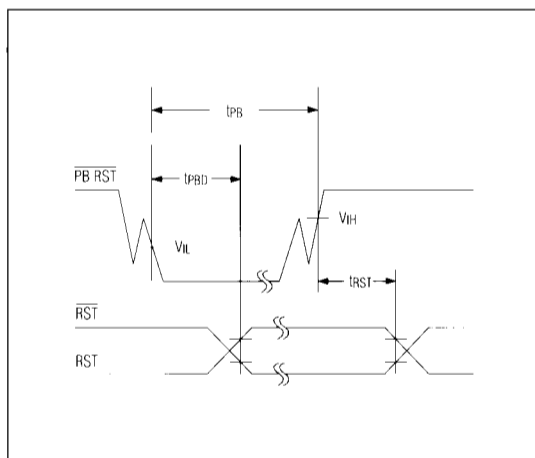

Figure 3. Pushbutton Reset. The debounced PB RST input ignores input pulses less than 1ms and is guaranteed to recognize pulses of 20ms or greater.

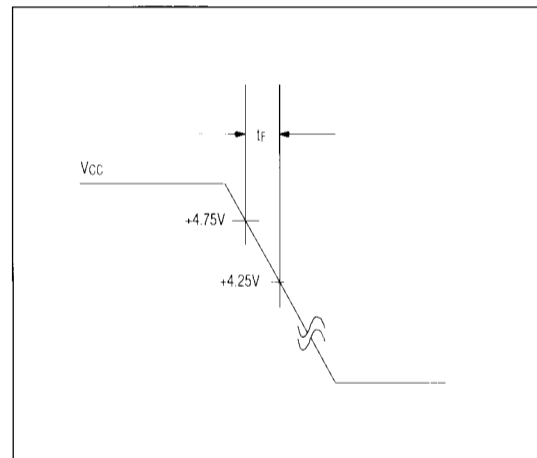

Figure 5. Power-Down Slew Rate

MAX1232 Microprocessor Monitor

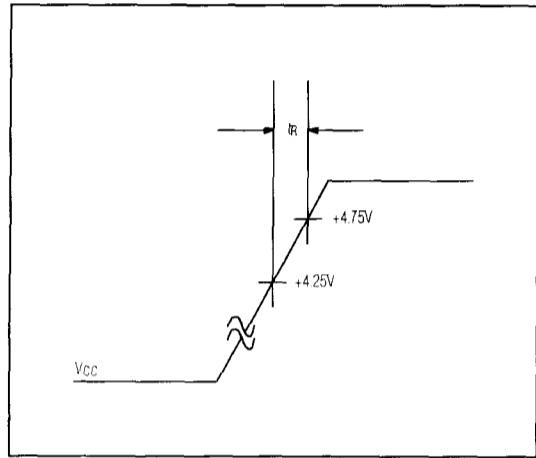

Figure 6. Power-Up Slew Rate

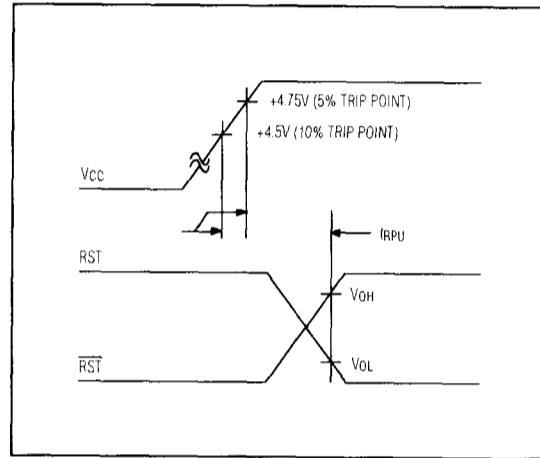

Figure 8. VCC Detect Reset Output Delay (Power-Up)

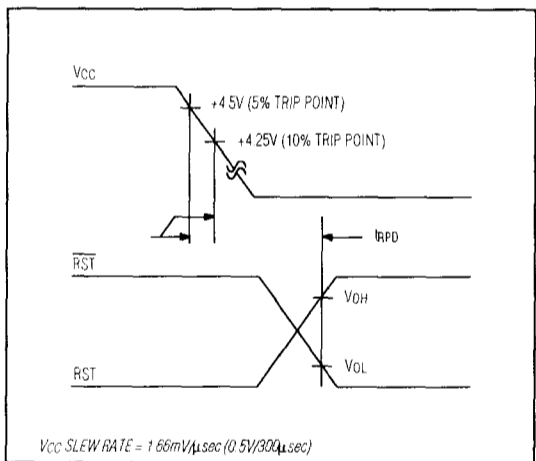

Figure 7. VCC Detect Reset Output Delay (Power-Down)

VCC SLEW RATE = 1.66mV/μsec (0.5V/300μsec)

Chip Topography

