

# MAX14576/MAX14636/MAX14637

## USB Charger Detectors

### General Description

The MAX14576/MAX14636/MAX14637 are USB charger detectors. The MAX14576/MAX14636/MAX14637 will pass USB Battery Charger Specification Revision 1.2 (USB BC 1.2) compliance tests. The MAX14636/MAX14637 can also detect Apple chargers, and other nonstandard types. These devices are capable of detecting multiple USB battery charging methods including standard downstream ports (SDP), charging downstream ports (CDP), and dedicated charger ports (DCP). The devices also feature USB BC 1.2 defined dead-battery option support.

The MAX14576/MAX14636/MAX14637 feature analog switches that are capable of passing USB Hi-Speed, full-speed, and low-speed signals. The switches have low on-resistance ( $3\Omega$ , typ) and low on-capacitance ( $4.5\text{pF}$ , typ). The CDN and CDP are high ESD protected up to  $\pm 15\text{kV}$  Human Body Model (HBM),  $\pm 15\text{kV}$  IEC61000-4-2 Air Gap Discharge, and  $\pm 8\text{kV}$  IEC61000-4-2 Contact Discharge.

The MAX14576/MAX14636/MAX14637 are available in a 10-pin ( $1.6\text{mm} \times 2.1\text{mm}$ ) UTQFN package and operate over the  $-40^\circ\text{C}$  to  $+85^\circ\text{C}$  extended temperature range.

### Applications

Cell Phones	Tablets
Digital Cameras	Portable Industrial Products
eReaders	

### Benefits and Features

- ◆ **High Level of Integration**
  - ◇ **Capability to Withstand -6V to +30V (Absolute Maximum) on VBUS Line**
  - ◇ **USB Battery Charger Detection Will Pass USB Battery Charger Specification Rev 1.2 Compliance Tests USB DCP, SDP, and CDP Detection Proprietary Charger Detection Capability (MAX14636/MAX14637)**
  - ◇ **USB 2.0 Hi-Speed Switch with  $3\Omega$  (typ) On-Resistance and  $4.5\text{pF}$  (typ) On-Capacitance**
  - ◇ **High ESD Protection on CDP and CDN**
    - $\pm 15\text{kV}$ —HBM
    - $\pm 15\text{kV}$ —IEC 61000-4-2 Air-Gap Discharge
    - $\pm 8\text{kV}$ —IEC 61000-4-2 Contact Discharge
  - ◇  **$\pm 15\text{kV}$  HBM ESD Protection VBUS When Bypassed with  $0.1\mu\text{F}$  or Greater Ceramic Capacitor**
- ◆ **Save Power in Portable Applications**
  - ◇ **Low Supply Current ( $150\mu\text{A}$ , typ)**
- ◆ **Space Saving**
  - ◇ **10-Pin,  $1.6\text{mm} \times 2.1\text{mm}$ , UTQFN Package**

*Ordering Information/Selector guide appears at end of data sheet.*

*For related parts and recommended products to use with this part, refer to [www.maximintegrated.com/MAX14576.related](http://www.maximintegrated.com/MAX14576.related).*

### Functional Diagram/Typical Application Circuit

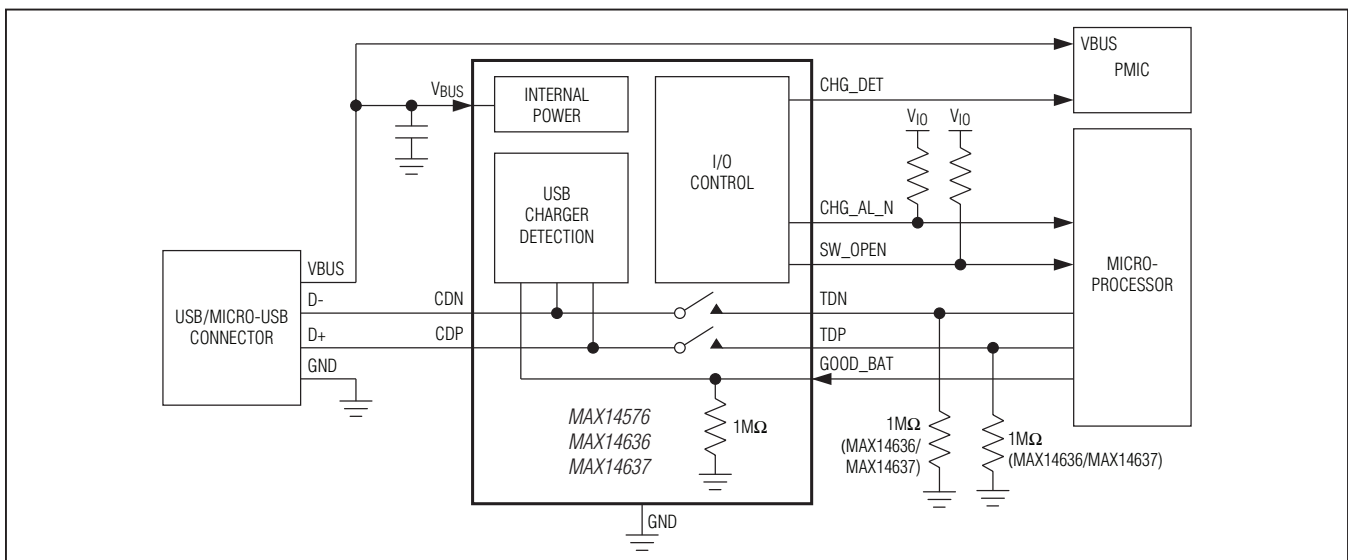

# ABRIDGED DATA SHEET

## MAX14576/MAX14636/MAX14637

### USB Charger Detectors

#### Pin Configuration

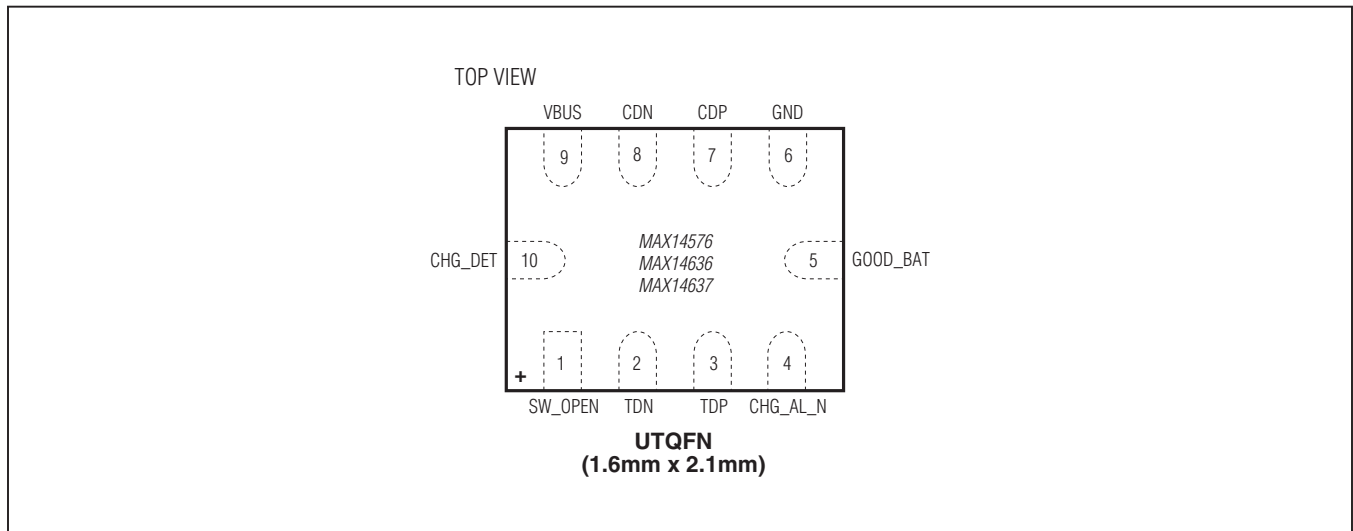

#### Pin Description

PIN	NAME	FUNCTION
1	SW_OPEN	Data Switches Open Indicator. SW_OPEN is low when switches are closed. SW_OPEN is high impedance when switches are open. SW_OPEN is an open-drain output. Connect SW_OPEN to a pullup resistor externally.
2	TDN	USB Transceiver D- Connection
3	TDP	USB Transceiver D+ Connection
4	CHG_AL_N	Charging Allow Indicator. CHG_AL_N is low when VBUS is valid and charging is allowed. CHG_AL_N is an open-drain output. Connect CHG_AL_N to a pullup resistor externally.
5	GOOD_BAT	Good Battery Digital Input. Set GOOD_BAT low for a dead battery and enable USB BC 1.2 compliant dead battery charging. Set GOOD_BAT high for a good battery.
6	GND	Ground
7	CDP	USB Connector D+ Connection
8	CDN	USB Connector D- Connection
9	VBUS	USB VBUS Input. Bypass VBUS to ground with a 0.1 $\mu$ F ceramic capacitor as close to the device as possible to achieve high $\pm$ 15kV HBM ESD protection.
10	CHG_DET	Charger Detection Push-Pull Output. CHG_DET indicates the capability of the connected charger type (see Tables 1, 2, 3).

# ABRIDGED DATA SHEET

## MAX14576/MAX14636/MAX14637

### USB Charger Detectors

#### Ordering Information/Selector Guide

PART	TEMP RANGE	APPLE CHARGE CURRENT	TomTom CHARGE CURRENT	TOP MARK	PIN-PACKAGE
MAX14576EVB+T	-40°C to +85°C	100mA	100mA	ABD	10 UTQFN
MAX14636EVB+T	-40°C to +85°C	Full Current	Full Current	ABE	10 UTQFN
MAX14637EVB+T	-40°C to +85°C	Full Current	Not Supported	ABG	10 UTQFN

+ Denotes a lead(Pb)-free package/RoHS-compliant package.  
T = Tape and reel

#### Chip Information

PROCESS: BiCMOS

#### Package Information

For the latest package outline information and land patterns (footprints), go to [www.maximintegrated.com/packages](http://www.maximintegrated.com/packages). Note that a "+", "#", or "-" in the package code indicates RoHS status only. Package drawings may show a different suffix character, but the drawing pertains to the package regardless of RoHS status.

PACKAGE TYPE	PACKAGE CODE	OUTLINE NO.	LAND PATTERN NO.
10 ULTRA TQFN	V101A2CN+1	<a href="#">21-0610</a>	<a href="#">90-0386</a>