

Drivers/Receivers

EIA-232-E and CCITT V.28

These devices are silicon gate CMOS ICs that combine both the transmitter and receiver to fulfill the electrical specifications of EIA Standard 232-E and CCITT V.28. The drivers feature true TTL input compatibility, slew rate limiting outputs, 300 Ω power-off source impedance, and output typically switching to within 25% of the supply rails. The receivers can handle up to ± 25 V while presenting 3 to 7 kΩ impedance. Hysteresis in the receivers aid in the reception of noisy signals. By combining both drivers and receivers in a single CMOS chip, these devices provide efficient, low-power solutions for both EIA-232-E and V.28 applications.

These devices offer the following performance features:

Drivers

- ± 5 to ± 12 V Supply Range
- 300 Ω Power-Off Source Impedance
- Output Current Limiting
- TTL and CMOS Compatible Inputs
- Driver Slew Rate Range Limited to 30 V/μs Maximum

Receivers

- ± 25 V Input Range
- 3 to 7 kΩ Input Impedance
- 0.8 V of Hysteresis for Enhanced Noise Immunity
- TTL and CMOS Compatible Outputs

Available Driver/Receiver Combinations

Device	Drivers	Receivers	Figure	No. of Pins
MC145403	3	5	1	20
MC145404	4	4	2	20
MC145405	5	3	3	20
MC145408	5	5	4	24

Alternative EIA-232 devices to consider are:

Three Supply

MC145406 (3 x 3)

Single Supply

MC145407 (3 x 3)

MC145705 (2 x 3) with Power Down

MC145706 (3 x 2) with Power Down

MC145707 (3 x 3) with Power Down

MC145403
MC145404
MC145405
MC145408

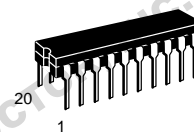

P SUFFIX
PLASTIC DIP
CASE 738

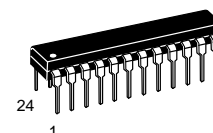

P SUFFIX
PLASTIC DIP
CASE 724

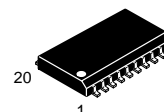

DW SUFFIX
SOG PACKAGE
CASE 751D

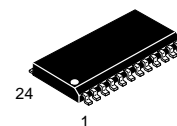

DW SUFFIX
SOG PACKAGE
CASE 751E

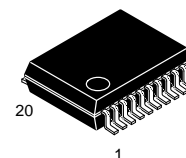

SD SUFFIX
SSOP
CASE 940C

ORDERING INFORMATION

MC145403P	Plastic DIP
MC145404P	Plastic DIP
MC145405P	Plastic DIP
MC145408P	Plastic DIP
MC145403DW	SOG Package
MC145404DW	SOG Package
MC145405DW	SOG Package
MC145408DW	SOG Package
MC145405SD	SSOP

PIN ASSIGNMENTS (DIP, SOG, AND SSOP)

MC145403
3 DRIVERS/5 RECEIVERS

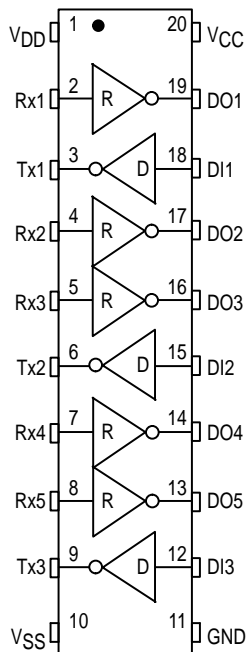

MC145404
4 DRIVERS/4 RECEIVERS

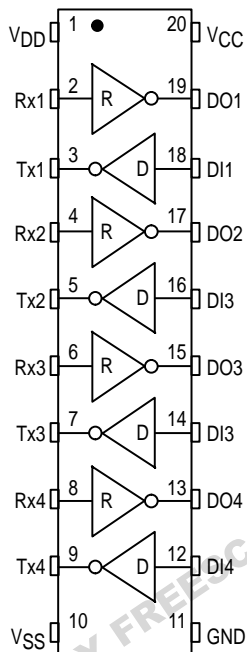

MC145405
5 DRIVERS/3 RECEIVERS

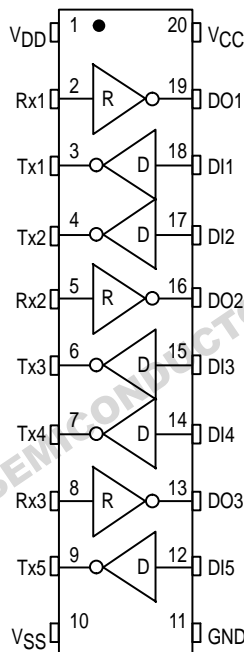

MC145408
5 DRIVERS/5 RECEIVERS

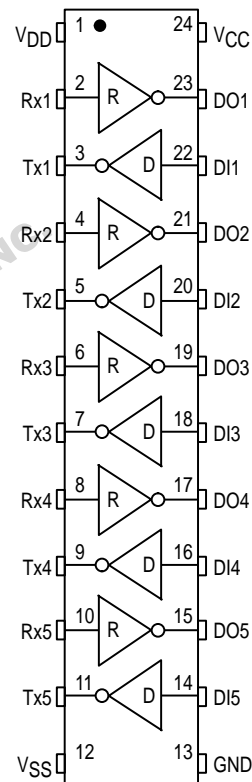

FUNCTIONAL DIAGRAM

RECEIVER

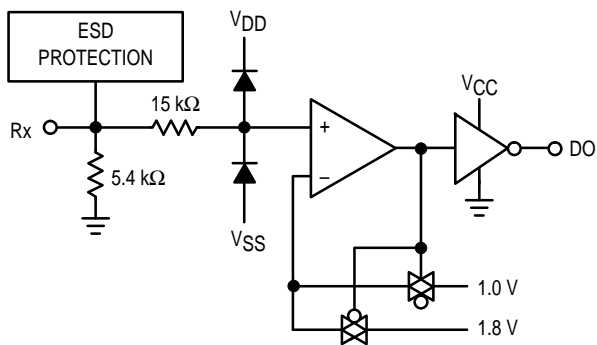

DRIVER

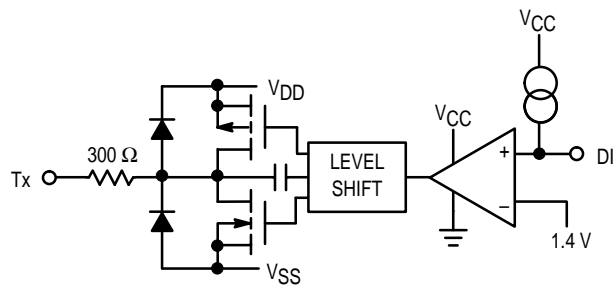

ABSOLUTE MAXIMUM RATINGS

(Voltages referenced to GND, except where noted)

Rating	Symbol	Value	Unit
DC Supply Voltage ($V_{DD} \geq V_{CC}$)	V_{DD} V_{SS} V_{CC}	- 0.5 to + 13.5 + 0.5 to - 13.5 - 0.5 to + 6.0	V
Input Voltage Range Rx1 – Rxn DI1 – DIN	V_{IR}	$V_{SS} - 15$ to $V_{DD} + 15$ 0.5 to $V_{CC} + 15$	V
DC Current Drain per Pin	I	± 00	mA
Power Dissipation	P_D	1	W
Operating Temperature Range	T_A	- 40 to + 85	°C
Storage Temperature Range	T_{stg}	- 85 to + 150	°C

This device contains circuitry to protect the inputs and outputs against damage due to high static voltages or electric fields; however, it is advised that normal precautions be taken to avoid applications of any voltage higher than maximum rated voltages to this high impedance circuit.

For proper operation it is recommended that V_{out} and V_{in} be constrained to the ranges described as follows:

Digital I/O: Driver Inputs (DI):

$$(GND \leq V_{DI} \leq V_{CC}).$$

Receiver Outputs (DO):

$$(GND \leq V_{DO} \leq V_{CC}).$$

EIA-232 I/O: Driver Outputs (Tx):

$$(V_{SS} \leq V_{Tx1} - T_{xn} \leq V_{DD}).$$

Receiver Inputs (Rx):

$$V_{SS} - 15 V \leq V_{Rx1} - R_{xn} \leq V_{DD} + 15 V).$$

Reliability of operation is enhanced if unused outputs are tied off to an appropriate logic voltage level (e.g., either GND or V_{CC} for DI, and GND for Rx).

DC ELECTRICAL CHARACTERISTICS (All polarities referenced to GND = 0 V, $T_A = -40$ to + 85°C)

Parameter	Symbol	Min	Typ	Max	Unit
DC Supply Voltage	V_{DD} V_{SS} V_{CC}	4.5 -4.5 4.5	5 to 12 -5 to -12 5	13.2 -13.2 5.5	V
Quiescent Supply Current (Outputs Unloaded, Inputs Low)	$V_{DD} = +12 V$ $V_{SS} = -12 V$ $V_{CC} = +5 V$	I_{DD} I_{SS} I_{CC}	— — —	425 -400 110	635 -600 200 μA

RECEIVER ELECTRICAL SPECIFICATIONS

(Voltage polarities referenced to GND = 0 V, $V_{DD} = +12 V$, $V_{SS} = -12 V$, $T_A = -40$ to + 85°C, $V_{CC} = +5 V$, ± 10%)

Characteristic	Symbol	Min	Typ	Max	Unit
Input Turn-On Threshold $V_{DO} = V_{OL}$	Rx1 – Rxn V_{on}	1.35	1.8	2.35	V
Input Turn-Off Threshold $V_{DO} = V_{OH}$	Rx1 – Rxn V_{off}	0.75	1	1.25	V
Input Threshold Hysteresis $\Delta = V_{on} - V_{off}$	V_{hys}	0.6	0.8	—	V
Input Resistance ($V_{SS} - 15 V \leq V_{Rx1} - R_{xn} \leq (V_{DD} + 15 V)$)	R_{in}	3	5.4	7	k Ω
High Level Output Voltage $V_{Rx} = -3$ to $-25 V^*$ (DO1 – DON)	$I_{out} = -20 \mu A$ $I_{out} = -1.0 mA$ V_{OH}	4.9 3.8	4.9 4.3	— —	V
Low Level Output Voltage $V_{Rx} = +3$ to $+25 V^*$ (DO1 – DON)	$I_{out} = +2 mA$ $I_{out} = +4 mA$ V_{OL}	— —	0.02 0.5	0.5 0.7	V

* This is the range of input voltages as specified by EIA-232-E to cause a receiver to be in the high or low.

DRIVER ELECTRICAL SPECIFICATIONS

(Voltage Polarities Referenced to GND = 0 V, $V_{DD} = +12$ V, $V_{SS} = -12$ V, $T_A = -40$ to $+85^\circ\text{C}$, $V_{CC} = +5$ V, $\pm 10\%$)

Characteristic	Symbol	Min	Typ	Max	Unit
Digital Input Voltage Logic 0 Logic 1	V_{IL} V_{IH}	— 2	— —	0.8 —	V
Input Current $V_{DI} = \text{GND}$ $V_{DI} = V_{CC}$	I_{IL} I_{IH}	— —	7 —	— ± 1.0	μA
Output High Voltage $V_{DI} = \text{Logic 0}$, $R_L = 3$ k Ω $V_{DD} = +5.0$ V, $V_{SS} = -5.0$ V $V_{DD} = +6.0$ V, $V_{SS} = -6.0$ V $V_{DD} = +12.0$ V, $V_{SS} = -12.0$ V	V_{OH}	3.5 4.3 9.2	3.9 4.7 9.5	— — —	V
Output Low Voltage* $V_{DI} = \text{Logic 1}$, $R_L = 3$ k Ω $V_{DD} = +5.0$ V, $V_{SS} = -5.0$ V $V_{DD} = +6.0$ V, $V_{SS} = -6.0$ V $V_{DD} = +12.0$ V, $V_{SS} = -12.0$ V	V_{OL}	-4 -4.5 -10	-4.3 -5.2 -10.3	— — —	V
Input Current (Figure 5)	Z_{off}	300	—	—	Ω
Output Short Circuit Current $V_{DD} = +12$ V, $V_{SS} = -12$ V Tx Shorted to GND** Tx Shorted to ± 15 V***	I_{SC}	— —	± 22 ± 60	± 60 ± 100	mA

* Voltage specifications are in terms of absolute values.

** Specification is for one Tx output pin to be shorted at a time. Should all three driver outputs be shorted simultaneously, device power dissipation limits will be exceeded.

*** This condition could exceed package limitations.

SWITCHING CHARACTERISTICS ($V_{CC} = +5$ V, $\pm 10\%$, $V_{DD} = +12$ V, $V_{SS} = -12$ V, $T_A = -40$ to $+85^\circ\text{C}$; See Figures 2 and 3)

Characteristic	Symbol	Min	Typ	Max	Unit
----------------	--------	-----	-----	-----	------

Drivers

Propagation Delay Time Tx Low-to-High $R_L = 3$ k Ω , $C_L = 50$ pF High-to-Low $R_L = 3$ k Ω , $C_L = 50$ pF	t_{PLH}	—	500	1000	ns
	t_{PHL}	—	700	1000	
Output Slew Rate Minimum Load $R_L = 7$ k Ω , $C_L = 0$ pF ($V_{DD} = 6$ to 12 V, $V_{SS} = -6$ to -12 V) Maximum Load $R_L = 3$ k Ω , $C_L = 2500$ pF ($V_{DD} = 12$ V, $V_{SS} = -12$ V, $V_{CC} = 5$ V)	SR	—	± 6	± 30	V/ μs
		4	—	—	

Receivers ($C_L = 50$ pF)

Propagation Delay Time Low-to-High High-to-Low	t_{PLH}	—	360	610	ns
	t_{PHL}	—	130	610	
Output Rise Time	t_r	—	250	400	ns
Output Fall Time	t_f	—	40	100	ns

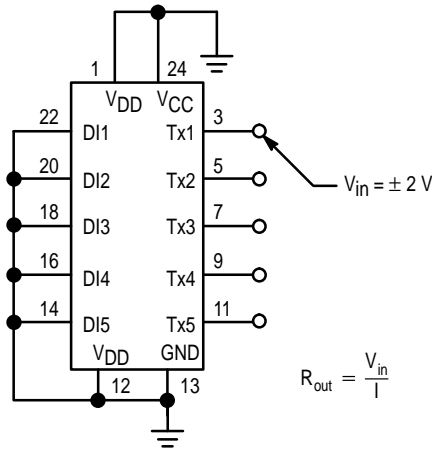

Figure 1. Power-Off Source Resistance Illustrated for MC145408

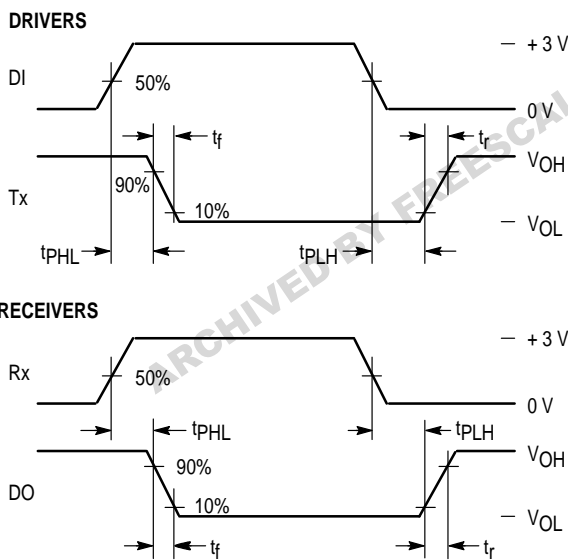

Figure 2. Switching Characteristics

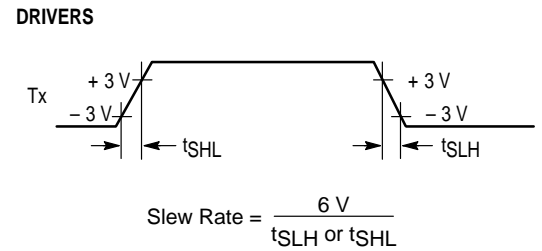

Figure 3. Slew Rate Characteristics

PIN DESCRIPTIONS

VCC
Digital Power Supply

The digital supply pin, which is connected to the logic power supply (+ 5.5 V maximum).

GND
Ground

Ground return pin is typically connected to the signal ground pin of the EIA-232-E connector (Pin 7) as well as to the logic power supply ground.

VDD
Most Positive Device Pin

The most positive power supply pin, which is typically + 5 to + 12 V.

VSS
Most Negative Device Pin

The most negative power supply pin, which is typically - 5 to - 12 V.

Rx1 - Rxn
Receive Data Input Pins

These are the EIA-232-E receive signal inputs. A voltage between + 3 and + 25 V is decoded as a space, and causes the corresponding DO pin to swing to ground (0 V). A voltage between - 3 and - 25 V is decoded as a mark, and causes the corresponding DO pin to swing to VCC.

DO1 - DON
Data Output Pins

These are the receiver digital output pins which swing from VCC to GND. Each output pin is capable of driving one LSTTL input load.

DI1 – DI n
Data Input Pins

These are the high impedance digital input pins to the drivers. Input voltage levels on these pins are LSTTL compatible and must be between V_{CC} and GND. A weak pull-up on each input sets all unused DI pins to V_{CC} , causing the corresponding unused driver outputs to be at V_{SS} .

Tx1 – Tx n
Transmit Data Output Pins

These are the EIA-232-E transmit signal output pins, which swing from V_{DD} to V_{SS} . A logic 1 at the DI input causes the corresponding Tx output to swing to V_{SS} . A logic 0 at the DI input causes the corresponding Tx out to swing to V_{DD} . The actual levels and slew rate achieved will depend on the output loading ($R_L \parallel C_L$).

APPLICATION INFORMATION

POWER SUPPLY CONSIDERATIONS

Figure 4 shows a technique to guard against excessive device current.

The diode D1 prevents excessive current from flowing through an internal diode from the V_{CC} pin to the V_{DD} pin when $V_{DD} < V_{CC}$ by approximately 0.6 V or greater. This high current condition can exist for a short period of time during power up/down. Additionally, if the + 12 V supply is switched

off while the + 5 V is on and the off supply is a low impedance to ground, the diode D1 will prevent current flow through the internal diode.

The diode D2 is used as a voltage clamp, to prevent V_{SS} from drifting positive to V_{CC} , in the event that power is removed from V_{SS} (Pin 12). If V_{SS} power is removed, and the impedance from the V_{SS} pin to ground is greater than approximately 3 k Ω , this pin will be pulled to V_{CC} by internal circuitry causing excessive current in the V_{CC} pin.

If by design, neither of the above conditions are allowed to exist, then the diodes D1 and D2 are not required.

ESD PROTECTION

ESD protection on IC devices that have their pins accessible to the outside world is essential. High static voltages applied to the pins when someone touches them either directly or indirectly can cause damage to gate oxides and transistor junctions by coupling a portion of the energy from the I/O pin to the power supply buses of the IC. This coupling will usually occur through the internal ESD protection diodes. The key to protecting the IC is to shunt as much of the energy to ground as possible before it enters the IC. Figure 4 shows a technique which will clamp the ESD voltage at approximately ± 15 V using the MMBZ15VDLT1. Any residual voltage which appears on the supply pins is shunted to ground through the capacitors C1 – C3. This scheme has provided protection to the interface part up to ± 10 kV, using the human body model test.

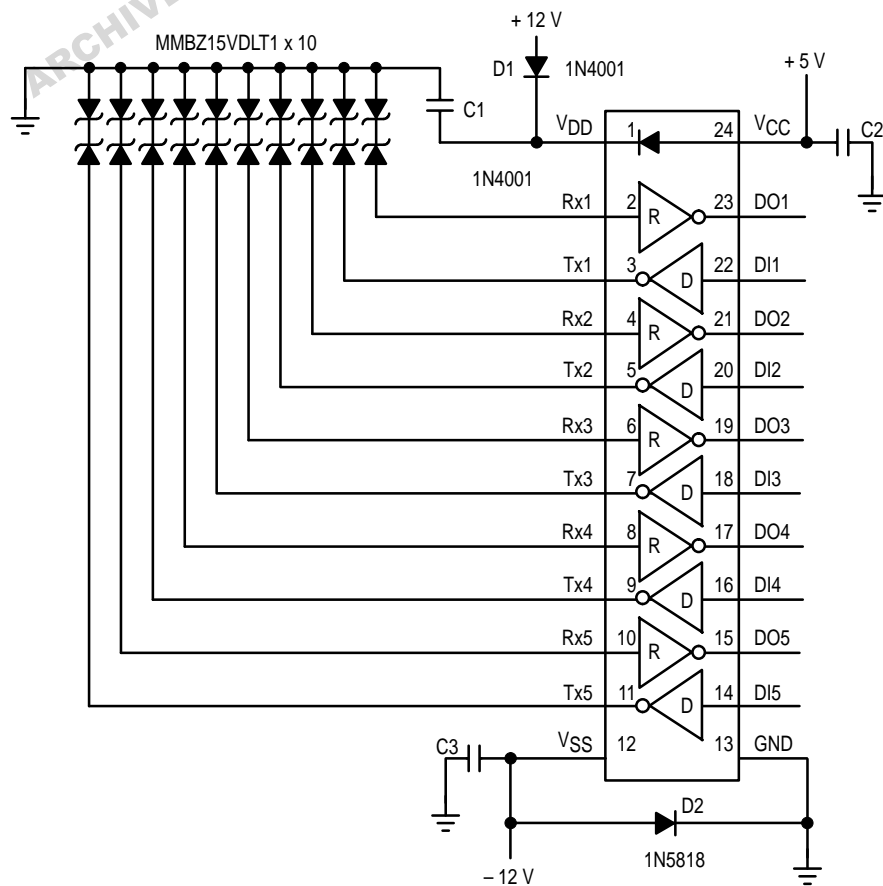
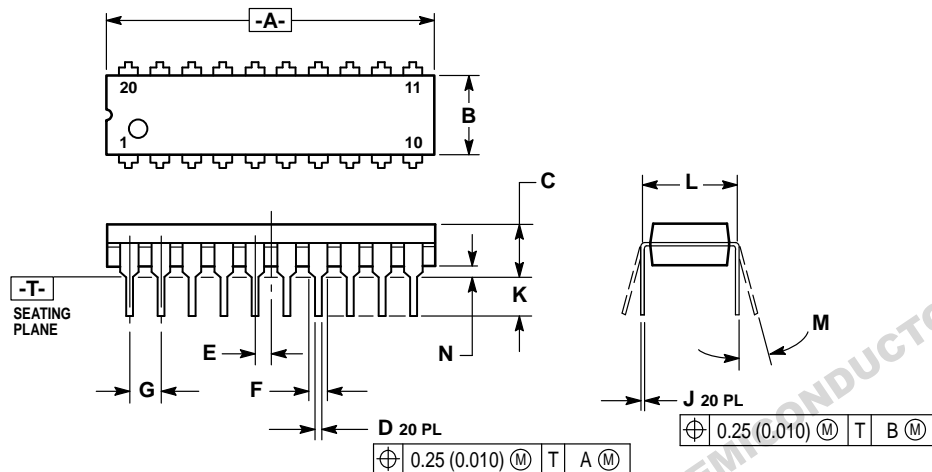

Figure 4.

PACKAGE DIMENSIONS

P SUFFIX PLASTIC DIP CASE 738-03



- NOTES:
1. DIMENSIONING AND TOLERANCING PER ANSI Y14.5M, 1982.
 2. CONTROLLING DIMENSION: INCH.
 3. DIMENSION L TO CENTER OF LEAD WHEN FORMED PARALLEL.
 4. DIMENSION B DOES NOT INCLUDE MOLD FLASH.

DIM	INCHES		MILLIMETERS	
	MIN	MAX	MIN	MAX
A	1.010	1.070	25.66	27.17
B	0.240	0.260	6.10	6.60
C	0.150	0.180	3.81	4.57
D	0.015	0.022	0.39	0.55
E	0.050 BSC		1.27 BSC	
F	0.050		1.27	
G	0.100 BSC		2.54 BSC	
J	0.008	0.015	0.21	0.38
K	0.110	0.140	2.80	3.55
L	0.300 BSC		7.62 BSC	
M	0°	15°	0°	15°
N	0.020	0.040	0.51	1.01

P SUFFIX PLASTIC DIP CASE 724-03

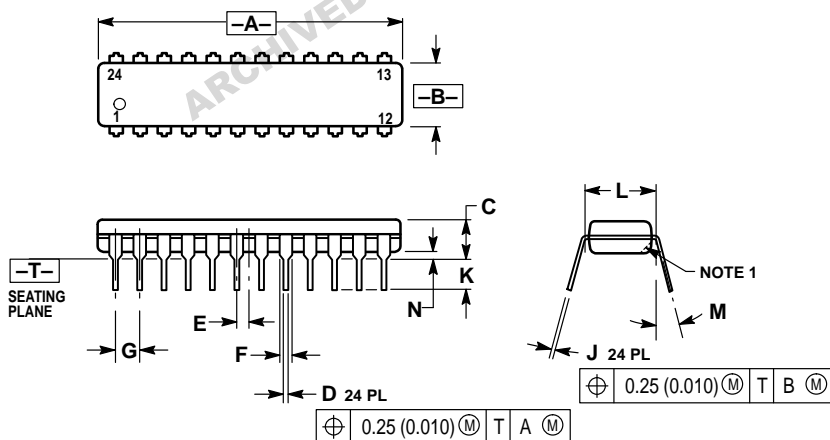

- NOTES:
1. CHAMFERED CONTOUR OPTIONAL.
 2. DIMENSION L TO CENTER OF LEADS WHEN FORMED PARALLEL.
 3. DIMENSIONING AND TOLERANCING PER ANSI Y14.5M, 1982.
 4. CONTROLLING DIMENSION: INCH.

DIM	INCHES		MILLIMETERS	
	MIN	MAX	MIN	MAX
A	1.230	1.265	31.25	32.13
B	0.250	0.270	6.35	6.85
C	0.145	0.175	3.69	4.44
D	0.015	0.020	0.38	0.51
E	0.050 BSC		1.27 BSC	
F	0.040	0.060	1.02	1.52
G	0.100 BSC		2.54 BSC	
J	0.007	0.012	0.18	0.30
K	0.110	0.140	2.80	3.55
L	0.300 BSC		7.62 BSC	
M	0°	15°	0°	15°
N	0.020	0.040	0.51	1.01

**DW SUFFIX
SOG PACKAGE
CASE 751D-04**

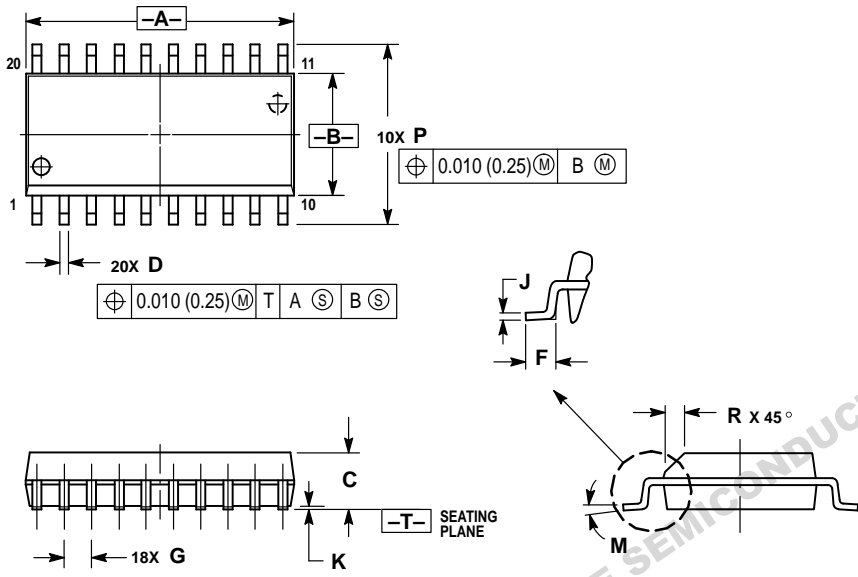

- NOTES:
1. DIMENSIONING AND TOLERANCING PER ANSI Y14.5M, 1982.
 2. CONTROLLING DIMENSION: MILLIMETER.
 3. DIMENSIONS A AND B DO NOT INCLUDE MOLD PROTRUSION.
 4. MAXIMUM MOLD PROTRUSION 0.150 (0.006) PER SIDE.
 5. DIMENSION D DOES NOT INCLUDE DAMBAR PROTRUSION. ALLOWABLE DAMBAR PROTRUSION SHALL BE 0.13 (0.005) TOTAL IN EXCESS OF D DIMENSION AT MAXIMUM MATERIAL CONDITION.

DIM	MILLIMETERS		INCHES	
	MIN	MAX	MIN	MAX
A	12.65	12.95	0.499	0.510
B	7.40	7.60	0.292	0.299
C	2.35	2.65	0.093	0.104
D	0.35	0.49	0.014	0.019
F	0.50	0.90	0.020	0.035
G	1.27 BSC		0.050 BSC	
J	0.25	0.32	0.010	0.012
K	0.10	0.25	0.004	0.009
M	0°	7°	0°	7°
P	10.05	10.55	0.395	0.415
R	0.25	0.75	0.010	0.029

**DW SUFFIX
SOG PACKAGE
CASE 751E-04**

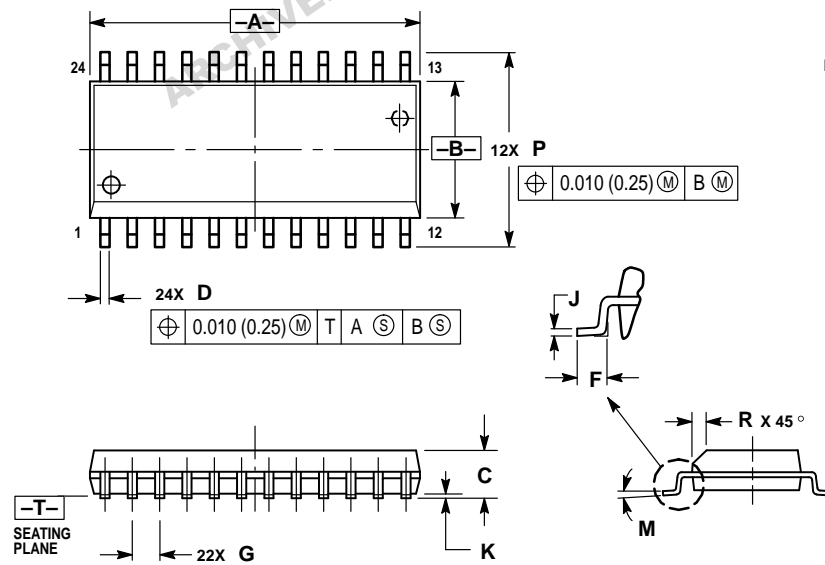

- NOTES:
1. DIMENSIONING AND TOLERANCING PER ANSI Y14.5M, 1982.
 2. CONTROLLING DIMENSION: MILLIMETER.
 3. DIMENSIONS A AND B DO NOT INCLUDE MOLD PROTRUSION.
 4. MAXIMUM MOLD PROTRUSION 0.15 (0.006) PER SIDE.
 5. DIMENSION D DOES NOT INCLUDE DAMBAR PROTRUSION. ALLOWABLE DAMBAR PROTRUSION SHALL BE 0.13 (0.005) TOTAL IN EXCESS OF D DIMENSION AT MAXIMUM MATERIAL CONDITION.

DIM	MILLIMETERS		INCHES	
	MIN	MAX	MIN	MAX
A	15.25	15.54	0.601	0.612
B	7.40	7.60	0.292	0.299
C	2.35	2.65	0.093	0.104
D	0.35	0.49	0.014	0.019
F	0.41	0.90	0.016	0.035
G	1.27 BSC		0.050 BSC	
J	0.23	0.32	0.009	0.013
K	0.13	0.29	0.005	0.011
M	0°	8°	0°	8°
P	10.05	10.55	0.395	0.415
R	0.25	0.75	0.010	0.029

**SD SUFFIX
SSOP
CASE 940C-03**

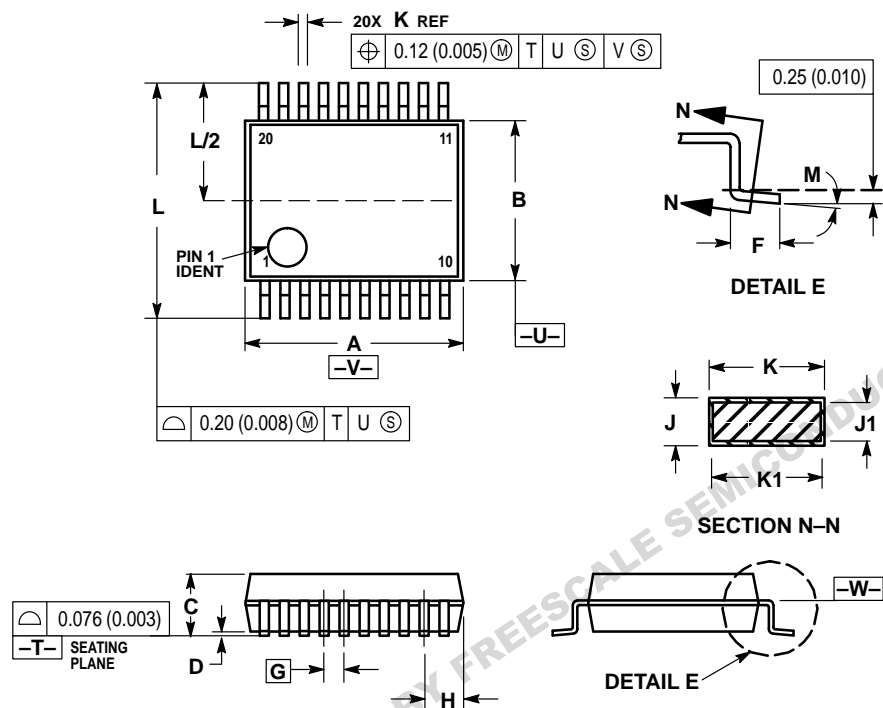

- NOTES:
1. DIMENSIONING AND TOLERANCING PER ANSI Y14.5M, 1982.
 2. CONTROLLING DIMENSION: MILLIMETER.
 3. DIMENSION A DOES NOT INCLUDE MOLD FLASH, PROTRUSIONS OR GATE BURRS. MOLD FLASH OR GATE BURRS SHALL NOT EXCEED 0.15 (0.006) PER SIDE.
 4. DIMENSION B DOES NOT INCLUDE INTERLEAD FLASH OR PROTRUSION. INTERLEAD FLASH OR PROTRUSION SHALL NOT EXCEED 0.15 (0.006) PER SIDE.
 5. DIMENSION K DOES NOT INCLUDE DAMBAR PROTRUSION/INTRUSION. ALLOWABLE DAMBAR PROTRUSION SHALL BE 0.13 (0.005) TOTAL IN EXCESS OF K DIMENSION AT MAXIMUM MATERIAL CONDITION. DAMBAR INTRUSION SHALL NOT REDUCE DIMENSION K BY MORE THAN 0.07 (0.002) AT LEAST MATERIAL CONDITION.
 6. TERMINAL NUMBERS ARE SHOWN FOR REFERENCE ONLY.
 7. DIMENSION A AND B ARE TO BE DETERMINED AT DATUM PLANE -W-.

DIM	MILLIMETERS		INCHES	
	MIN	MAX	MIN	MAX
A	7.07	7.33	0.278	0.288
B	5.20	5.38	0.205	0.212
C	1.73	1.99	0.068	0.078
D	0.05	0.21	0.002	0.008
F	0.63	0.95	0.024	0.037
G	0.65 BSC		0.026 BSC	
H	0.59	0.75	0.023	0.030
J	0.09	0.20	0.003	0.008
J1	0.09	0.16	0.003	0.006
K	0.25	0.38	0.010	0.015
K1	0.25	0.33	0.010	0.013
L	7.65	7.90	0.301	0.311
M	0°	8°	0°	8°

Motorola reserves the right to make changes without further notice to any products herein. Motorola makes no warranty, representation or guarantee regarding the suitability of its products for any particular purpose, nor does Motorola assume any liability arising out of the application or use of any product or circuit, and specifically disclaims any and all liability, including without limitation consequential or incidental damages. "Typical" parameters which may be provided in Motorola data sheets and/or specifications can and do vary in different applications and actual performance may vary over time. All operating parameters, including "Typicals" must be validated for each customer application by customer's technical experts. Motorola does not convey any license under its patent rights nor the rights of others. Motorola products are not designed, intended, or authorized for use as components in systems intended for surgical implant into the body, or other applications intended to support or sustain life, or for any other application in which the failure of the Motorola product could create a situation where personal injury or death may occur. Should Buyer purchase or use Motorola products for any such unintended or unauthorized application, Buyer shall indemnify and hold Motorola and its officers, employees, subsidiaries, affiliates, and distributors harmless against all claims, costs, damages, and expenses, and reasonable attorney fees arising out of, directly or indirectly, any claim of personal injury or death associated with such unintended or unauthorized use, even if such claim alleges that Motorola was negligent regarding the design or manufacture of the part. Motorola and are registered trademarks of Motorola, Inc. Motorola, Inc. is an Equal Opportunity/Affirmative Action Employer.

How to reach us:
USA/EUROPE/Locations Not Listed: Motorola Literature Distribution;
 P.O. Box 5405, Denver, Colorado 80217. 1-303-675-2140 or 1-800-441-2447

Mfax™: RMFAX0@email.sps.mot.com – TOUCHTONE 1-602-244-6609
 Motorola Fax Back System – US & Canada ONLY 1-800-774-1848
 – http://sps.motorola.com/mfax/

HOME PAGE: http://motorola.com/sps/

Mfax is a trademark of Motorola, Inc.

JAPAN: Nippon Motorola Ltd.: SPD, Strategic Planning Office, 141,
 4-32-1 Nishi-Gotanda, Shagawa-ku, Tokyo, Japan. 03-5487-8488

ASIA/PACIFIC: Motorola Semiconductors H.K. Ltd.; 8B Tai Ping Industrial Park,
 51 Ting Kok Road, Tai Po, N.T., Hong Kong. 852-26629298

CUSTOMER FOCUS CENTER: 1-800-521-6274