



RS232C QUAD LINE DRIVER

- CURRENT LIMITED OUTPUT ± 10 mA TYP.
- POWER-OFF SOURCE IMPEDANCE 300 Ω MIN.
- SIMPLE SLEW RATE CONTROL WITH EXTERNAL CAPACITOR
- FLEXIBLE OPERATING SUPPLY RANGE
- INPUTS ARE TTL AND μ P COMPATIBLE

DESCRIPTION

The MC1488 is a monolithic quad line driver designed to interface data terminal equipment with data communications equipment in conformance with the specifications of EIA Standard No. RS232C.

DIP-14 (0.25)
(Plastic and Ceramic)

SO-14J

ORDER CODES : MC1488P (Plastic DIP)
MC1488L (Ceramic DIP)
MC1488D (SO-14)

TYPICAL APPLICATION : RS232C Data Transmission.

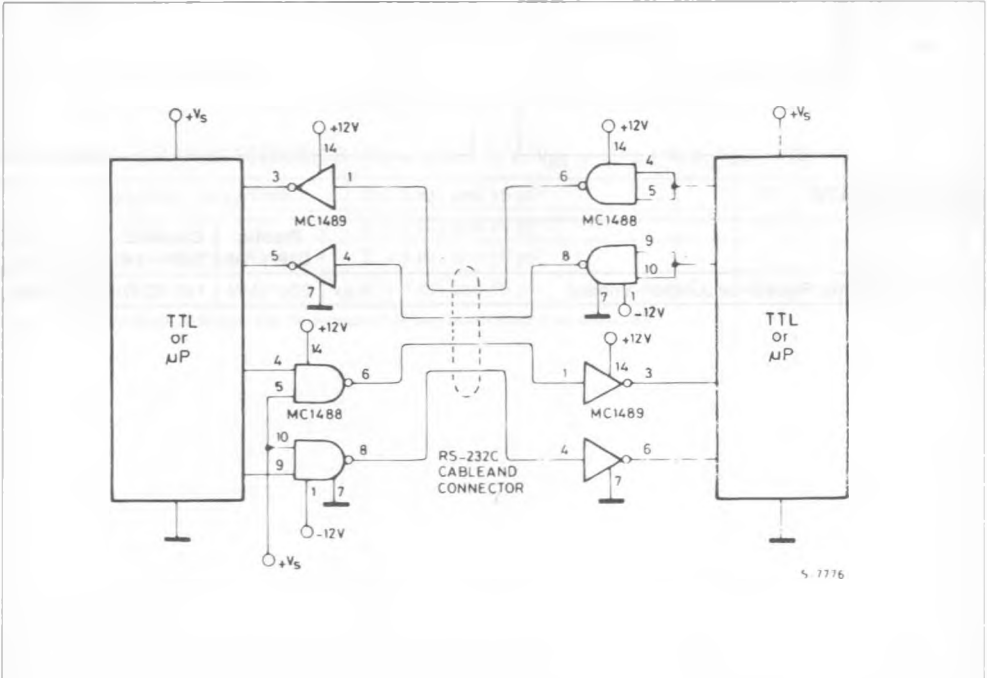

ABSOLUTE MAXIMUM RATINGS

Symbol	Parameter	Value	Unit
V_S	Power Supply Voltage	15	V
V_{EE}	Power Supply Voltage	- 15	V
V_{IR}	Input Voltage Range	$- 15 \leq V_{IR} \leq 7$	V
V_O	Output Signal Voltage	± 15	V
T_{amb}	Operating Ambient Temperature	0 to 75	°C
T_{slg}	Storage Temperature Range	- 65 to 150	°C

CONNECTION DIAGRAMS (top views)

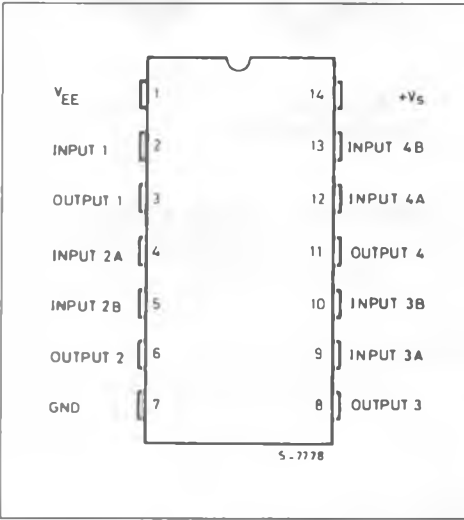

LOGIC DIAGRAM

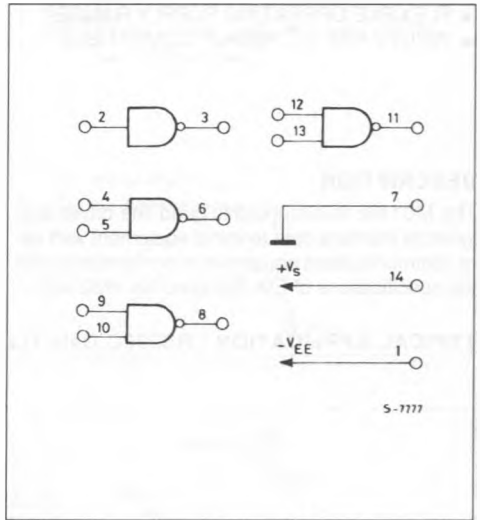

THERMAL DATA

		Plastic DIP - 14	Ceramic DIP - 14	SO - 14
$\theta_{th(j-amb)}$	Thermal Resistance Junction-ambient	max 200 °C/W	165 °C/W	165 °C/W

ELECTRICAL CHARACTERISTICS ($V_S = 9 \pm 10\% V$, $V_{EE} = -9 \pm 10\% V$, $T_{amb} = 0$ to $75\text{ }^\circ\text{C}$ unless otherwise specified)

Symbol	Parameter	Test Conditions	Min.	Typ.	Max.	Unit	Fig.
I_{IL}	Input Current	Low Logic State ($V_{IL} = 0V$)		1	1.6	mA	1
I_{IH}	Input Current	High Logic State ($V_{IH} = 5V$)			10	μA	1
V_{OH}	Output Voltage	High Logic State $R_L = 3K\Omega$ $V_{IL} = 0.8V$, $V_S = 9V$, $V_{EE} = -9V$ $V_{IL} = 0.8V$, $V_S = 13.2V$, $V_{EE} = -13.2V$	6 9	7 10.5		V V	2 2
V_{OL}	Output Voltage	Low Logic State $R_L = 3K\Omega$ $V_{IH} = 1.9V$, $V_{EE} = -9V$, $V_S = 9V$ $V_{IH} = 1.9V$, $V_{EE} = -13.2V$, $V_S = 13.2V$	-6 -9	-7 -10.5		V V	2 2
I_{OS+}	Positive Output Short-circuit Current		6	10	12	mA	3
I_{OS-}	Negative Output Short-circuit Current		-6	-10	-12	mA	3
R_O	Output Resistance	$V_S = V_{EE} = 0$ $ V_O = \pm 2V$	300			Ω	4
I_S	Positive Supply Current ($R_L = \infty$)	$V_{IH} = 1.9V$ $V_S = 9V$ $V_{IL} = 0.8V$ $V_S = 9V$ $V_{IH} = 1.9V$ $V_S = 12V$ $V_{IL} = 0.8V$ $V_S = 12V$ $V_{IH} = 1.9V$ $V_S = 15V$ $V_{IL} = 0.8V$ $V_S = 15V$		15 4.5 19 5.5	20 6 25 7 34 12	mA	5
I_{EE}	Negative Supply Current ($R_L = \infty$)	$V_{IH} = 1.9V$ $V_{EE} = -9V$ $V_{IL} = 0.8V$ $V_{EE} = -9V$ $V_{IH} = 1.9V$ $V_{EE} = -12V$ $V_{IL} = 0.8V$ $V_{EE} = -12V$ $V_{IH} = 1.9V$ $V_{EE} = -15V$ $V_{IL} = 0.8V$ $V_{EE} = -15V$		-13 -18	-17 -15 -23 -15 -34 -2.5	mA μA mA μA mA mA	5
P_C	Power Consumption	$V_S = 9V$ $V_{EE} = -9V$ $V_S = 12V$ $V_{EE} = -12V$			333 567	mW	

SWITCHING CHARACTERISTICS ($V_S = \pm 9 \pm 1\% V$, $V_{EE} = -9 \pm 1\% V$, $T_{amb} = 25\text{ }^\circ\text{C}$)

t_{PLH}	Propagation Delay Time	$Z_i = 3K\Omega$ and $15pF$		275	350	ns	6
t_{THL}	Fall Time	$Z_i = 3K\Omega$ and $15pF$		45	75	ns	6
t_{PHL}	Propagation Delay Time	$Z_i = 3K\Omega$ and $15pF$		110	175	ns	6
t_{TLH}	Rise Time	$Z_i = 3K\Omega$ and $15pF$		55	100	ns	6

* Maximum package power dissipation may be exceeded if all outputs are shorted simultaneously

TEST CIRCUITS

Figure 1 : Input Current.

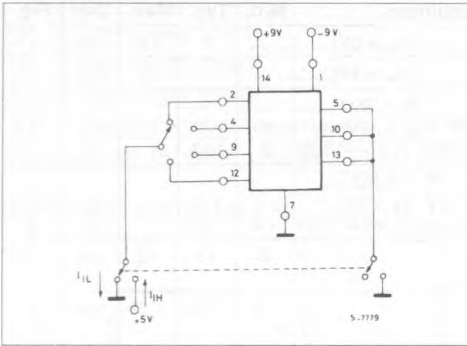

Figure 2 : Output Voltage.

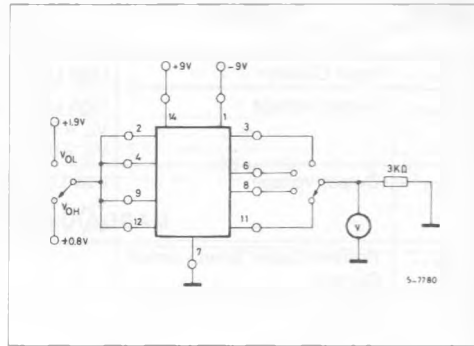

Figure 3 : Output Short-Circuit Current.

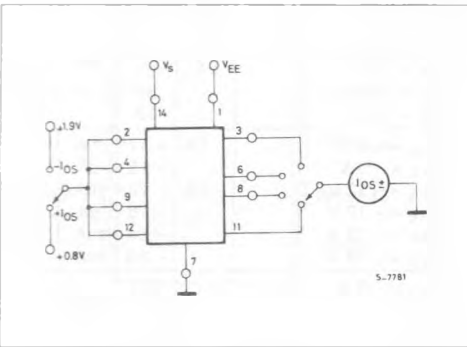

Figure 4 : Output Resistance (power off).

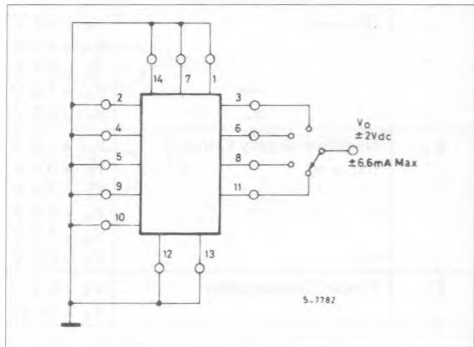

Figure 5 : Power Supply Currents.

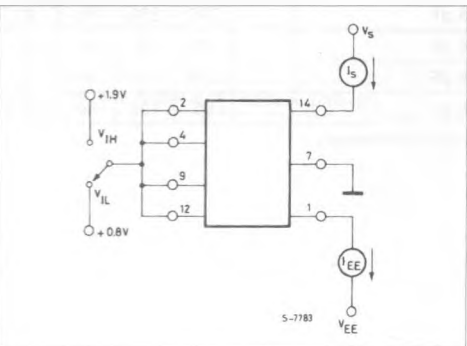

Figure 6 : Switching Response.

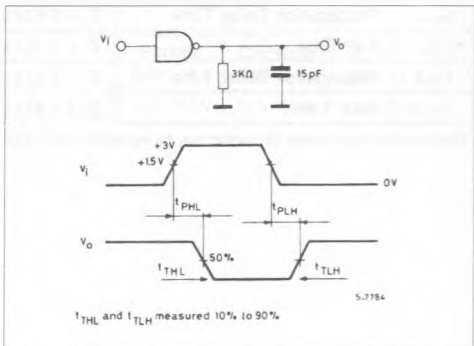

Figure 7 : Transfer Characteristics vs. Power Supply Voltage.

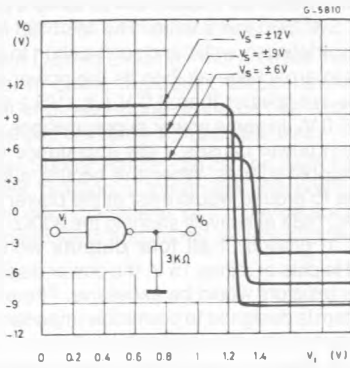

Figure 8 : Short-Circuit Output Current vs. Temperature.

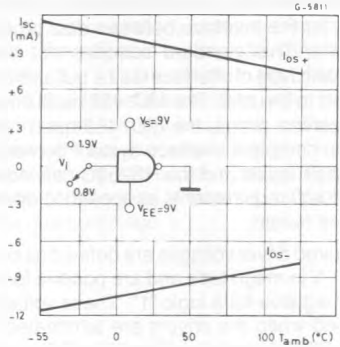

Figure 9 : Output Slew-Rate Load Capacitance.

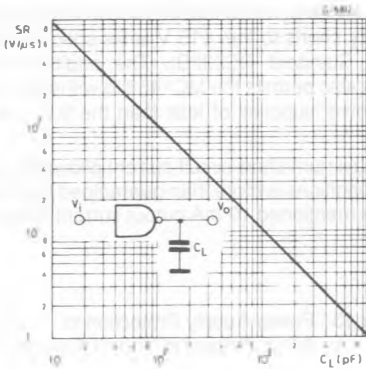

Figure 10 : Output Voltage and Current-Limiting Characteristics.

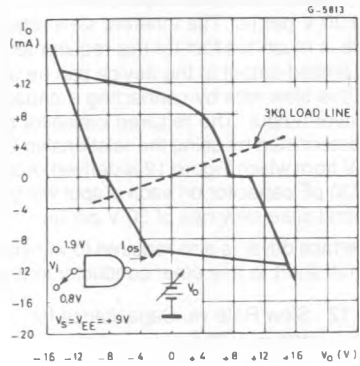
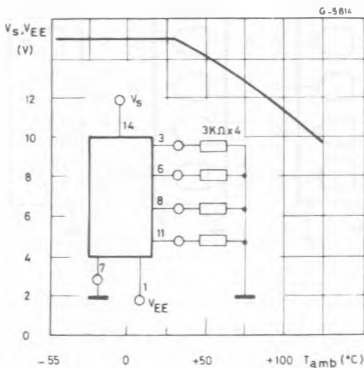

Figure 11 : Maximum Operating Temperature vs. Power-Supply Voltage.



APPLICATION INFORMATION

The Electronic Industries Association (EIA) has released the RS232C specification detailing the requirements for the interface between data processing equipment. This standard specifies not only the number and type of interface leads, but also the voltage levels to be used. The MC1488 quad driver and its companion circuit, the MC1489 quad receiver, provide a complete interface system between DTL or TTL logic levels and the RS232C defined levels. The RS232C requirements as applied to drivers are discussed herein.

The required driver voltages are defined as between 5 and 15 V in magnitude and are positive for a logic "0" and negative for a logic "1". These voltages are so defined when the drivers are terminated with a 3000 to 7000Ω resistor. The MC1488 meets this voltage requirement by converting a DTL/TTL logic level into RS232C levels with one stage of inversion.

The RS232C specification further requires that during transitions, the driver output slew rate must not exceed 30 V per μs. The inherent slew rate of the MC1488 is much too fast for this requirement. The current limited output of the device can be used to control this slew rate by connecting a capacitor to each driver output. The required capacitor can be easily determined by using the relationship $C = I_{OS} \times \Delta T / \Delta V$ from which Figure 12 is derived. Accordingly, a 330 pF capacitor on each output will guarantee a worst case slew rate of 30 V per μs.

The interface driver is also required to withstand an accidental short to any other conductor in an inter-

connecting cable. The worst possible signal on any conductor would be another driver using a plus or minus 15 V, 500 mA source. The MC1488 is designed to indefinitely withstand such a short to all four outputs in a package as long as the power-supply voltages are greater than 9.0 V (i.e., $V_S \geq 9.0 V$; $V_{EE} \leq -9.0 V$). In some power-supply designs, a loss of system power causes a low impedance on the power-supply outputs. When this occurs, a low impedance to ground would exist at the power inputs to the MC1488 effectively shorting the 300Ω output resistor to ground. If **all four outputs** were then shorted to plus or minus 15 V, the power dissipation in these resistors would be excessive. Therefore, if the system is designed to permit low impedances to ground at the power-supplies of the drivers, a diode should be placed in each power-supply lead to prevent over-heating in this fault condition. These two diodes, as shown in Figure 13, could be used to decouple all the driver packages in a system. (These same diodes will allow the MC1488 to withstand momentary shorts to the ±15 V limits specified in the earlier Standard RS232B). The addition of the diodes also permits the MC1488 to withstand faults with power-supplies of less than the 9.0 V stated above.

The maximum short-circuit current allowable under fault conditions is more than guaranteed by the previously mentioned 10 mA output current limiting.

Figure 12 : Slew Rate vs. Capacitance for $I_{SC} = 10mA$.

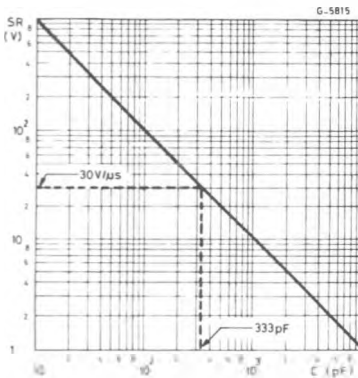
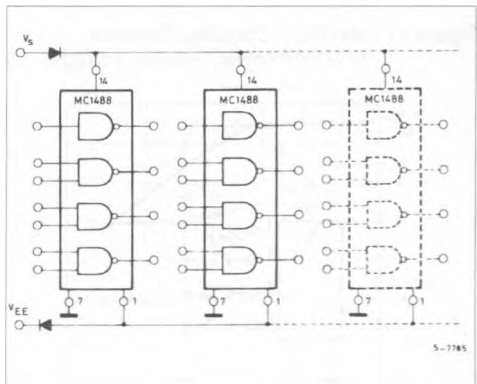

Figure 13 : Power Supply Protection to Meet Power-off Fault Conditions.



OTHER APPLICATION

The MC1488 is an extremely versatile line driver with a myriad of possible applications. Several features of the drivers enhance this versatility :

1. Output Current Limiting - this enables the circuit designer to define the output voltage levels independent of power-supplies and can be accomplished by diode clamping of the output pins.

2. Power-Supply Range - as can be seen from the schematic drawing of the drivers, the positive and negative driving elements of the device are essentially independent and do not require matching po-

wer-supplies. In fact, the positive supply can vary from a minimum seven volts (required for driving the negative pulldown section) to the maximum specified 15 V. The negative supply can vary from approximately - 2.5 V to the minimum specified - 15 V. The MC1488 will drive the output to within 2 V of the positive or negative supplies as long as the current output limits are not exceeded. The combination of the current-limiting and supply-voltage features allow a wide combination of possible outputs within the same quad package.