

MC1741C

Internally Compensated, High Performance Operational Amplifier

The MC1741C was designed for use as a summing amplifier, integrator, or amplifier with operating characteristics as a function of the external feedback components.

- No Frequency Compensation Required
- Short Circuit Protection
- Offset Voltage Null Capability
- Wide Common Mode and Differential Voltage Ranges
- Low Power Consumption
- No Latch Up

MAXIMUM RATINGS

Rating	Symbol	Value	Unit
Power Supply Voltage	V_{CC}, V_{EE}	± 18	Vdc
Input Differential Voltage	V_{ID}	± 30	V
Input Common Mode Voltage (Note 1)	V_{ICM}	± 15	V
Output Short Circuit Duration (Note 2)	t_{SC}	Continuous	
Operating Ambient Temperature Range	T_A	0 to +70	°C
Storage Temperature Range	T_{stg}	-55 to +125	°C

NOTES: 1. For supply voltages less than +15 V, the absolute maximum input voltage is equal to the supply voltage.
2. Supply voltage equal to or less than 15 V.

OPERATIONAL AMPLIFIER

SEMICONDUCTOR TECHNICAL DATA

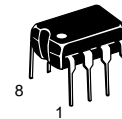

P1 SUFFIX
PLASTIC PACKAGE
CASE 626



D SUFFIX
PLASTIC PACKAGE
CASE 751
(SO-8)

PIN CONNECTIONS

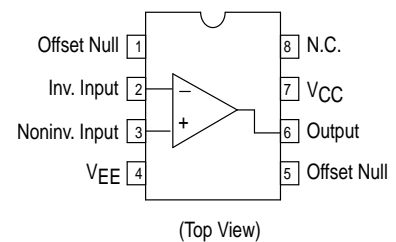

Equivalent Circuit Schematic (1/4 of Circuit Shown)

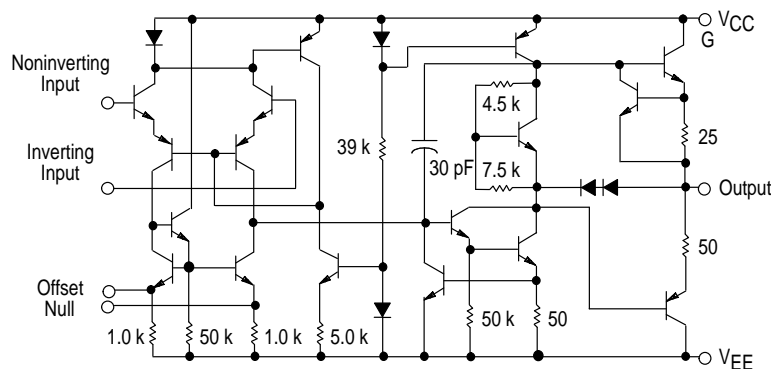

ORDERING INFORMATION

Device	Alternate	Operating Temperature Range	Package
MC1741CD	-	$T_A = 0^\circ \text{ to } +70^\circ \text{C}$	SO-8
MC1741CP1	LM741CN $\mu\text{A}741\text{TC}$		Plastic DIP

MC1741C

ELECTRICAL CHARACTERISTICS ($V_{CC} = +15\text{ V}$, $V_{EE} = -15\text{ V}$, $T_A = 25^\circ\text{C}$, unless otherwise noted.)

Characteristic	Symbol	Min	Typ	Max	Unit
Input Offset Voltage ($R_S \leq 10\text{ k}$)	V_{IO}	–	2.0	6.0	mV
Input Offset Current	I_{IO}	–	20	200	nA
Input Bias Current	I_{IB}	–	80	500	nA
Input Resistance	r_i	0.3	2.0	–	$M\Omega$
Input Capacitance	C_i	–	1.4	–	pF
Offset Voltage Adjustment Range	V_{IOR}	–	± 15	–	mV
Common Mode Input Voltage Range	V_{ICR}	± 12	± 13	–	V
Large Signal Voltage Gain ($V_O = \pm 10\text{ V}$, $R_L \geq 2.0\text{ k}$)	A_{VOL}	20	200	–	V/mV
Output Resistance	r_o	–	75	–	Ω
Common Mode Rejection ($R_S \leq 10\text{ k}$)	CMR	70	90	–	dB
Supply Voltage Rejection ($R_S \leq 10\text{ k}$)	PSR	75	–	–	dB
Output Voltage Swing ($R_L \geq 10\text{ k}$) ($R_L \geq 2.0\text{ k}$)	V_O	± 12 ± 10	± 14 ± 13	– –	V
Output Short Circuit Current	I_{SC}	–	20	–	mA
Supply Current	I_D	–	1.7	2.8	mA
Power Consumption	P_C	–	50	85	mW
Transient Response (Unity Gain, Noninverting) ($V_I = 20\text{ mV}$, $R_L \geq 2.0\text{ k}$, $C_L \leq 100\text{ pF}$) Rise Time ($V_I = 20\text{ mV}$, $R_L \geq 2.0\text{ k}$, $C_L \leq 100\text{ pF}$) Overshoot ($V_I = 10\text{ V}$, $R_L \geq 2.0\text{ k}$, $C_L \leq 100\text{ pF}$) Slew Rate	t_{LH} os SR	– – –	0.3 15 0.5	– – –	μs % V/ μs

ELECTRICAL CHARACTERISTICS ($V_{CC} = +15\text{ V}$, $V_{EE} = -15\text{ V}$, $T_A = T_{low}$ to T_{high} , unless otherwise noted.)*

Characteristic	Symbol	Min	Typ	Max	Unit
Input Offset Voltage ($R_S \leq 10\text{ k}\Omega$)	V_{IO}	–	–	7.5	mV
Input Offset Current ($T_A = 0^\circ$ to $+70^\circ\text{C}$)	I_{IO}	–	–	300	nA
Input Bias Current ($T_A = 0^\circ$ to $+70^\circ\text{C}$)	I_{IB}	–	–	800	nA
Supply Voltage Rejection ($R_S \leq 10\text{ k}$)	PSR	75	–	–	dB
Output Voltage Swing ($R_L \geq 2.0\text{ k}$)	V_O	± 10	± 13	–	V
Large Signal Voltage Gain ($R_L \geq 2.0\text{ k}$, $V_O = \pm 10\text{ V}$)	A_{VOL}	15	–	–	V/mV

* $T_{low} = 0^\circ\text{C}$ $T_{high} = 70^\circ\text{C}$

Figure 1. Burst Noise versus Source Resistance

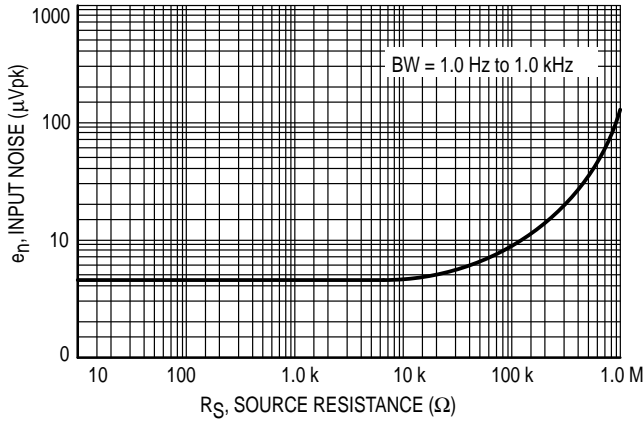

Figure 2. RMS Noise versus Source Resistance

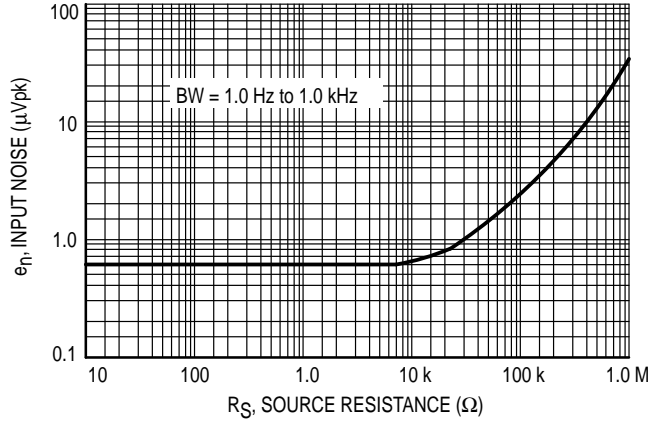

Figure 3. Output Noise versus Source Resistance

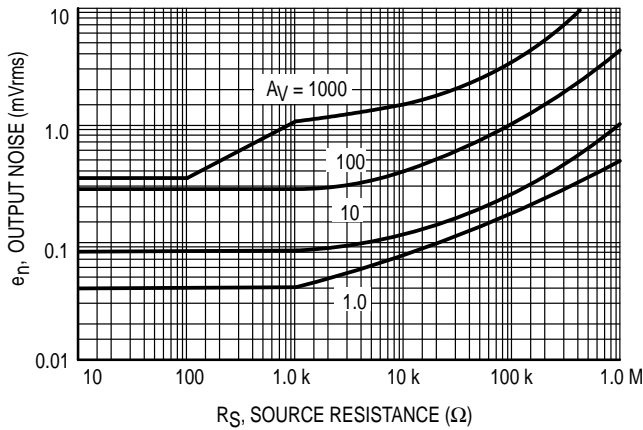

Figure 4. Spectral Noise Density

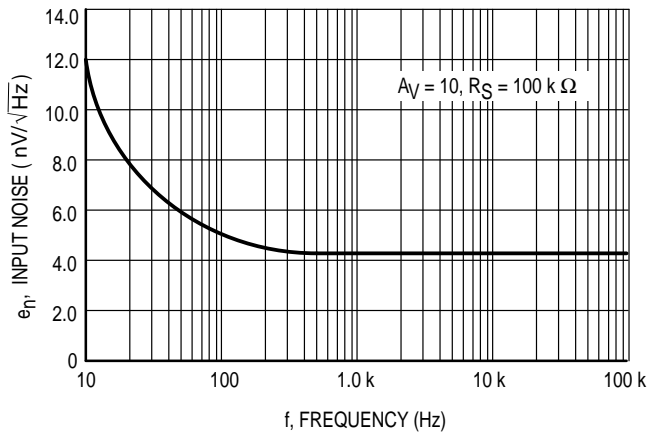
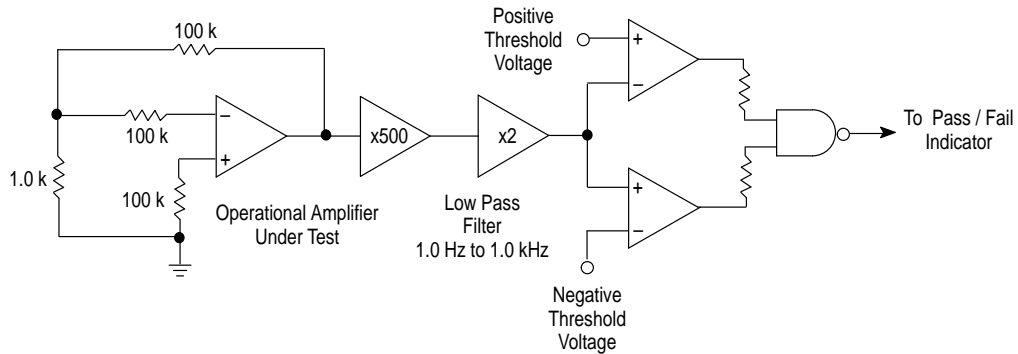

Figure 5. Burst Noise Test Circuit



Unlike conventional peak reading or RMS meters, this system was especially designed to provide the quick response time essential to burst (popcorn) noise testing.

The test time employed is 10 sec and the 20 mV peak limit refers to the operational amplifier input thus eliminating errors in the closed loop gain factor of the operational amplifier.

**Figure 6. Power Bandwidth
(Large Signal Swing versus Frequency)**

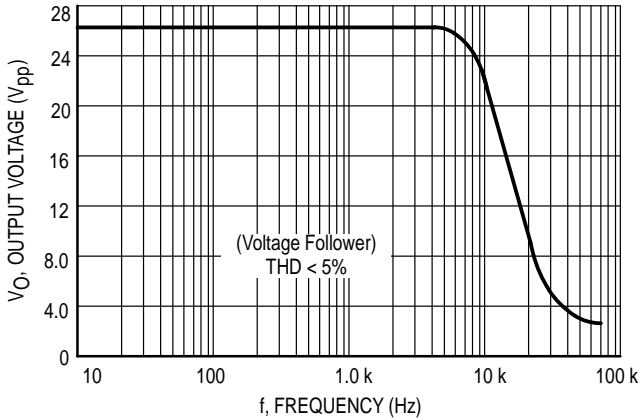
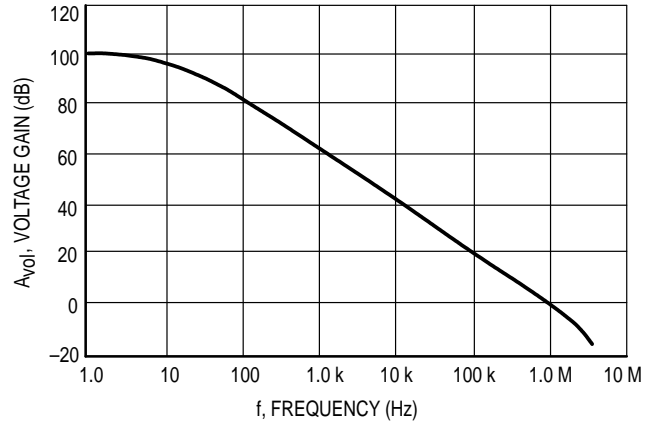
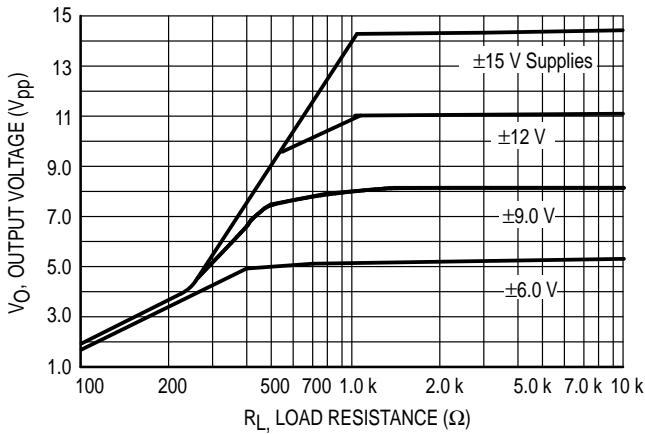

Figure 7. Open Loop Frequency Response



**Figure 8. Positive Output Voltage Swing
versus Load Resistance**



**Figure 9. Negative Output Voltage Swing
versus Load Resistance**

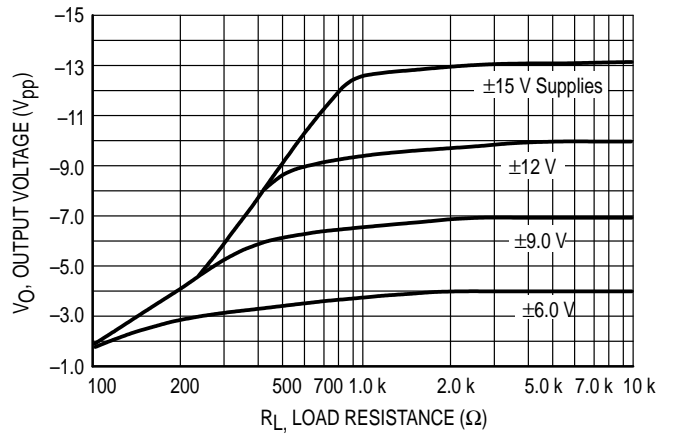

**Figure 10. Output Voltage Swing versus
Load Resistance (Single Supply Operation)**

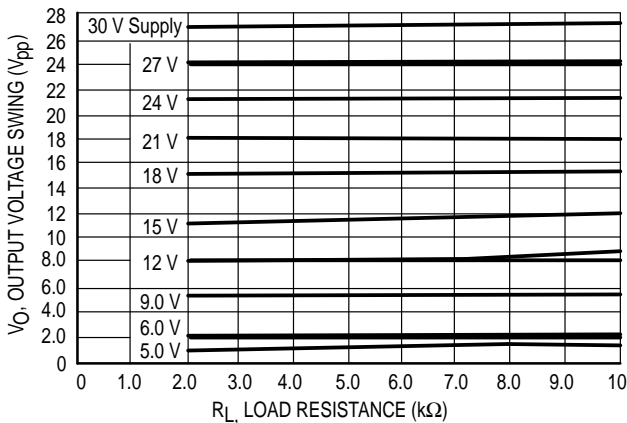
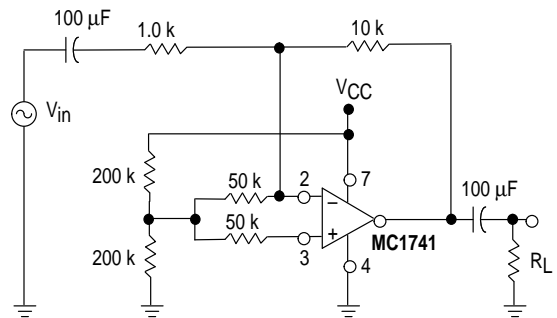

Figure 11. Single Supply Inverting Amplifier



MC1741C

Figure 12. Noninverting Pulse Response

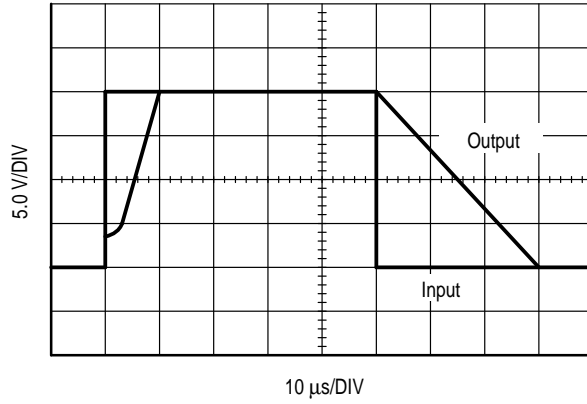

Figure 13. Transient Response Test Circuit

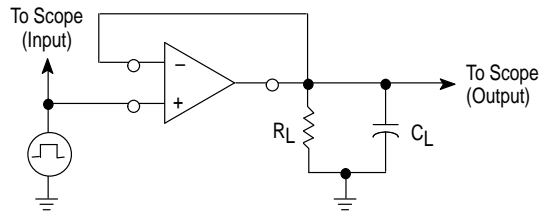
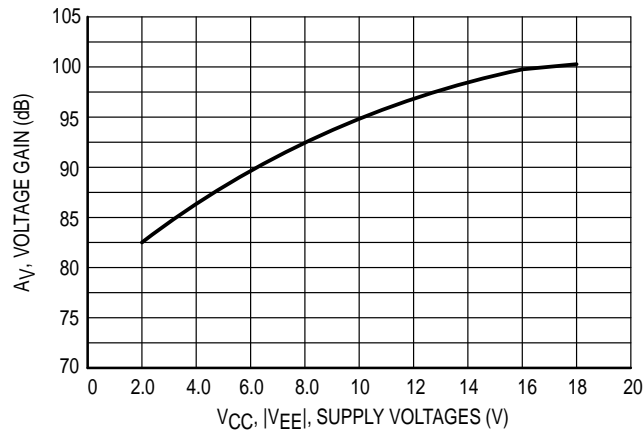

Figure 14. Open Loop Voltage Gain versus Supply Voltage



Motorola reserves the right to make changes without further notice to any products herein. Motorola makes no warranty, representation or guarantee regarding the suitability of its products for any particular purpose, nor does Motorola assume any liability arising out of the application or use of any product or circuit, and specifically disclaims any and all liability, including without limitation consequential or incidental damages. "Typical" parameters which may be provided in Motorola data sheets and/or specifications can and do vary in different applications and actual performance may vary over time. All operating parameters, including "Typicals" must be validated for each customer application by customer's technical experts. Motorola does not convey any license under its patent rights nor the rights of others. Motorola products are not designed, intended, or authorized for use as components in systems intended for surgical implant into the body, or other applications intended to support or sustain life, or for any other application in which the failure of the Motorola product could create a situation where personal injury or death may occur. Should Buyer purchase or use Motorola products for any such unintended or unauthorized application, Buyer shall indemnify and hold Motorola and its officers, employees, subsidiaries, affiliates, and distributors harmless against all claims, costs, damages, and expenses, and reasonable attorney fees arising out of, directly or indirectly, any claim of personal injury or death associated with such unintended or unauthorized use, even if such claim alleges that Motorola was negligent regarding the design or manufacture of the part. Motorola and  are registered trademarks of Motorola, Inc. Motorola, Inc. is an Equal Opportunity/Affirmative Action Employer.

MC1741C

How to reach us:

USA/EUROPE/Locations Not Listed: Motorola Literature Distribution;
P.O. Box 20912; Phoenix, Arizona 85036. 1-800-441-2447 or 602-303-5454

MFAX: RMFAX0@email.sps.mot.com – TOUCHTONE 602-244-6609
INTERNET: <http://Design-NET.com>

JAPAN: Nippon Motorola Ltd.; Tatsumi-SPD-JLDC, 6F Seibu-Butsuryu-Center,
3-14-2 Tatsumi Koto-Ku, Tokyo 135, Japan. 03-81-3521-8315

ASIA/PACIFIC: Motorola Semiconductors H.K. Ltd.; 8B Tai Ping Industrial Park,
51 Ting Kok Road, Tai Po, N.T., Hong Kong. 852-26629298



MOTOROLA



MC1741C/D

