

MC34268

800 mA, 2.85 V, SCSI-2 Active Terminator, Low Dropout Voltage Regulator

The MC34268 is a medium current, low dropout positive voltage regulator specifically designed for use in SCSI-2 active termination circuits. This device offers the circuit designer an economical solution for precision voltage regulation, while keeping power losses to a minimum. The regulator consists of a 1.0 V dropout composite PNP/NPN pass transistor, current limiting, and thermal limiting. These devices are packaged in the 8-pin SOP-8 and 3-pin DPAK and SOT-223 surface mount power packages.

Applications include active SCSI-2 terminators and post regulation of switching power supplies.

- 2.85 V Output Voltage for SCSI-2 Active Termination
- 1.0 V Dropout
- Output Current in Excess of 800 mA
- Thermal Protection
- Short Circuit Protection
- Output Trimmed to 1.4% Tolerance
- No Minimum Load Required
- Space Saving DPAK, SOT-223 and SOP-8 Surface Mount Power Packages

Simplified Block Diagram

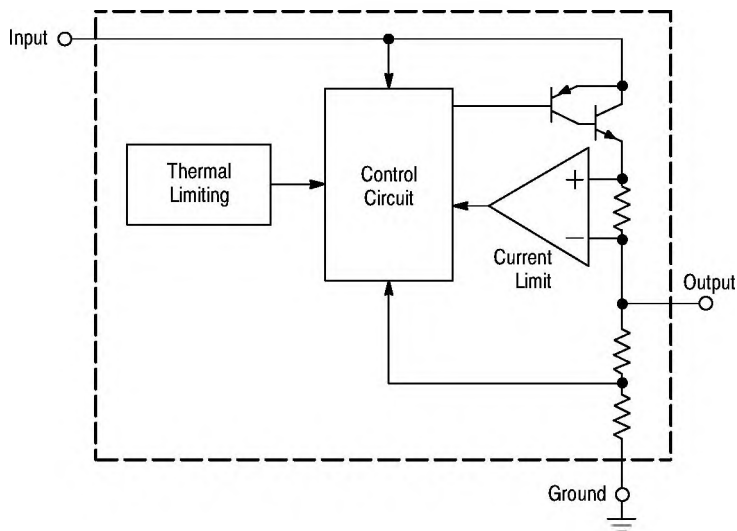

ON Semiconductor™

<http://onsemi.com>

MARKING DIAGRAMS



SOP-8
D SUFFIX
CASE 751

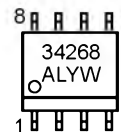

A = Assembly Location
L = Wafer Lot
Y = Year
W = Work Week

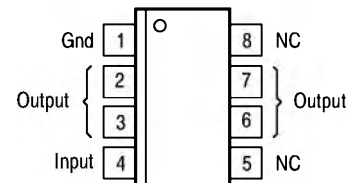

(Top View)

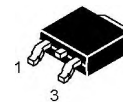

DPAK
DT SUFFIX
CASE 369A



SOT-223
ST SUFFIX
CASE 318E

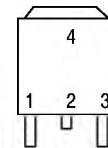
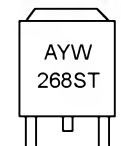

(Top View)

Heatsink surface (shown as terminal 4 in case outline drawing) is connected to Pin 2.

ORDERING INFORMATION

See detailed ordering and shipping information in the package dimensions section on page 614 of this data sheet.

MAXIMUM RATINGS

Rating	Symbol	Value	Unit
Power Supply Input Voltage	V_{in}	15	V
Power Dissipation and Thermal Characteristics			
DT Suffix, Plastic Package, Case 369A $T_A = 25^\circ\text{C}$, Derate Above $T_A = 25^\circ\text{C}$	P_D	Internally Limited	W
Thermal Resistance, Junction-to-Case	$R_{\theta JC}$	5.0	$^\circ\text{C/W}$
Thermal Resistance, Junction-to-Air	$R_{\theta JA}$	87	$^\circ\text{C/W}$
D Suffix, Plastic Package, Case 751 $T_A = 25^\circ\text{C}$, Derate Above $T_A = 25^\circ\text{C}$	P_D	Internally Limited	W
Thermal Resistance, Junction-to-Case	$R_{\theta JC}$	22	$^\circ\text{C/W}$
Thermal Resistance, Junction-to-Air	$R_{\theta JA}$	140	$^\circ\text{C/W}$
ST Suffix, Plastic Package, Case 318E $T_A = 25^\circ\text{C}$, Derate Above $T_A = 25^\circ\text{C}$	P_D	Internally Limited	W
Thermal Resistance, Junction-to-Case	$R_{\theta JC}$	15	$^\circ\text{C/W}$
Thermal Resistance, Junction-to-Air	$R_{\theta JA}$	245	$^\circ\text{C/W}$
Operating Junction Temperature Range	T_J	0 to +150	$^\circ\text{C}$
Storage Temperature	T_{stg}	- 55 to +150	$^\circ\text{C}$

ELECTRICAL CHARACTERISTICS

($V_{in} = 4.25\text{ V}$, $C_O = 10\ \mu\text{F}$, for typical values $T_J = 25^\circ\text{C}$, for min/max values $T_J = 0^\circ\text{C}$ to $+125^\circ\text{C}$, unless otherwise noted.)

Characteristic	Symbol	Min	Typ	Max	Unit
Output Voltage ($T_J = 25^\circ\text{C}$, $I_O = 0\text{ mA}$) Output Voltage, over Line, Load, and Temperature ($V_{in} = 3.9\text{ V}$ to 15 V , $I_O = 0\text{ mA}$ to 490 mA)	V_O	2.81 2.76	2.85 2.85	2.89 2.93	V
Line Regulation ($V_{in} = 4.25\text{ V}$ to 15 V , $I_O = 0\text{ mA}$, $T_J = 25^\circ\text{C}$)	Reg_{line}	—	—	0.3	%
Load Regulation ($I_O = 0\text{ mA}$ to 800 mA , $T_J = 25^\circ\text{C}$)	Reg_{load}	—	—	0.5	%
Dropout Voltage ($I_O = 490\text{ mA}$)	$V_{in} - V_O$	—	0.95	1.1	V
Ripple Rejection ($f = 120\text{ Hz}$)	RR	55	—	—	dB
Maximum Output Current ($V_{in} = 5.0\text{ V}$)	$I_{(max)}$	800	—	—	mA
Bias Current ($V_{in} = 4.25\text{ V}$, $I_O = 0\text{ mA}$)	I_B	—	5.0 to 3.0	8.0	mA
Minimum Load Current to maintain Regulation ($V_{in} = 15\text{ V}$)	$I_{L(min)}$	—	—	0	mA

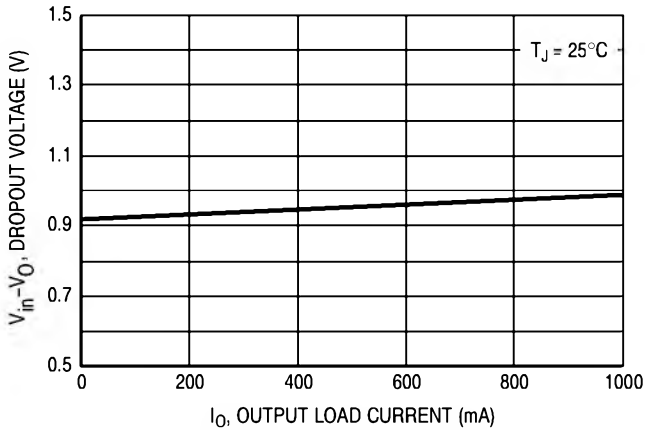

Figure 1. Dropout Voltage versus Output Load Current

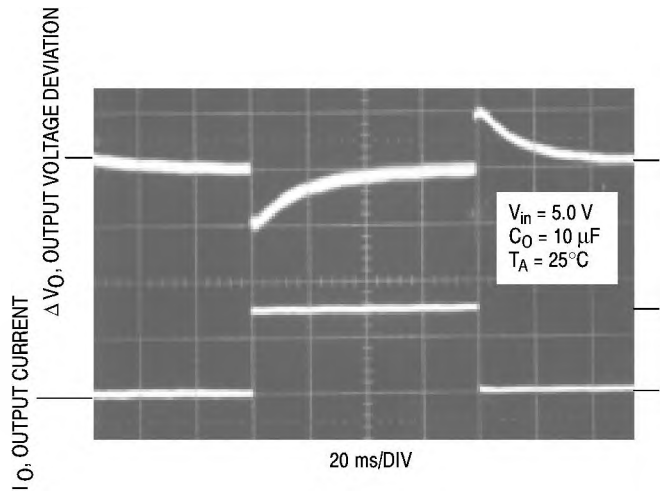

Figure 2. Transient Load Regulation

MC34268

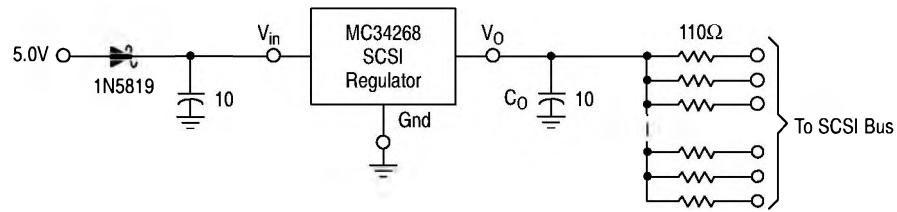

Figure 3. Typical SCSI Application

Figure 3 is a circuit of a typical SCSI terminator application. The MC34268 is designed specifically to provide 2.85 V required to drive a SCSI-2 bus. The output current capability of the regulator is in excess of 800 mA; enough to drive standard SCSI-2, fast SCSI-2, and some wide SCSI-2 applications. The typical dropout voltage is less than 1.0 V, allowing the IC to regulate to input voltages less than 4.0 V. Internal protective features include current and thermal limiting.

The MC34268 requires an external 10 µF capacitor with an ESR of less than 10 Ω for stability over temperature. With economical electrolytic capacitors, cold temperature operation can pose a stability problem. As temperature decreases, the capacitance also decreases and the ESR increases, which could cause the circuit to oscillate. Tantalum capacitors may be a better choice if small size is a requirement. Also, the capacitance and ESR of a tantalum capacitor is more stable over temperature.

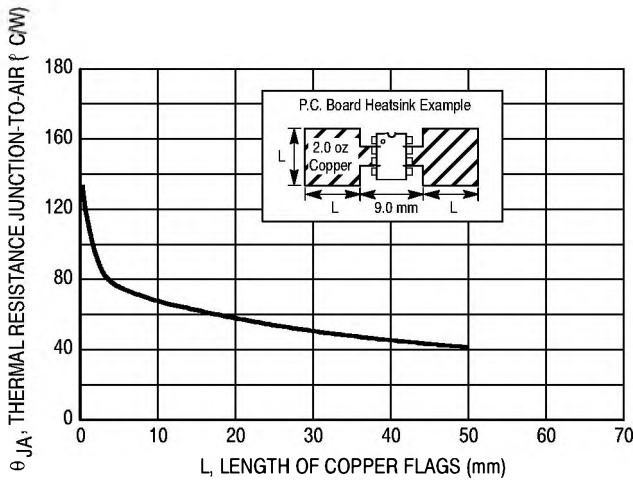

Figure 4. SOP-8 Thermal Resistance versus P.C.B. Copper Length

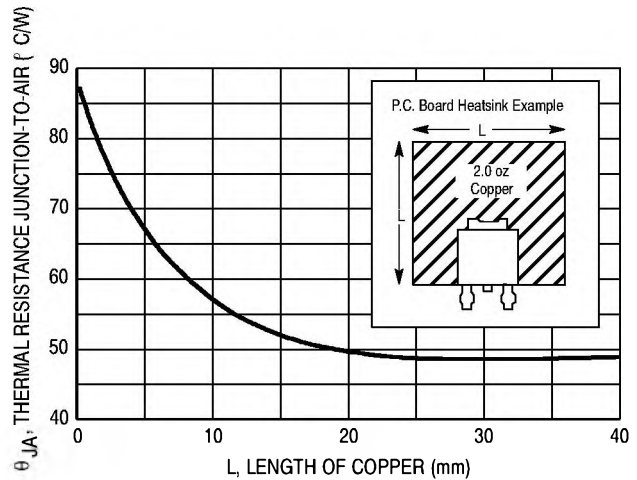

Figure 5. DPAK Thermal Resistance versus P.C.B. Copper Length

ORDERING INFORMATION

Device	Package	Shipping Information
MC34268D	SO-8	98 Units / Rail
MC34268DR2	SO-8	2500 Units / Tape & Reel
MC34268DT	DPAK	75 Units / Rail
MC34268DTRK	DPAK	2500 Units / Tape & Reel
MC34268STT3	SOT-223	4000 Units / Tape & Reel