



Analog, Mixed Signal and Power Management

MC35XS3400

Quad 35 mOhm High Side Switch

Overview

Freescale Semiconductor's third generation of its award-winning eXtreme Switch portfolio features devices tailored for automotive lighting applications. These high-

power switches include the MC35XS3400 which is designed to drive automotive light sources, improve efficiency, reduce wire harness size and provide increased protection for longer bulb life. Featuring four

low RDS(ON) MOSFETs (quad 35 mΩ), the MC35XS3400 can control four separate 28 W bulbs and/or LEDs. Programming, control and diagnostics are accomplished using a 16-bit SPI interface. Its output with selectable slew-rate improves electromagnetic compatibility (EMC) behavior. Additionally, each output has its own parallel input or SPI control for pulse-width modulation (PWM) control if desired. The MC35XS3400 allows the user to program via the SPI the fault current trip levels and duration of acceptable lamp inrush. The device has fail-safe mode to provide Fail-safe functionality of the outputs in case of damaged MCU.

MC35XS3400 Applications

- Low-voltage automotive lighting
 - Halogen bulbs
 - Light-emitting diodes (LEDs)
 - High beam
 - Low beam
 - Flashers

MC35XS3400 Simplified Application Diagram

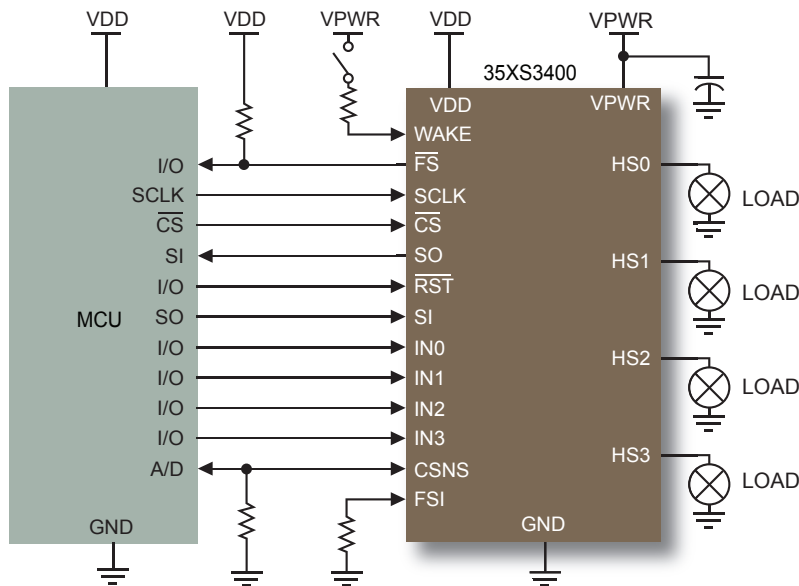

MC35XS3400 Product Features

- Four protected 35 mΩ high side switches (at 25 °C)
- Operating voltage range of 6.0 to 20 V with standby current < 5.0 μA, extended mode from 4.0 to 28 V
- 8.0 MHz 16-bit 3.3 V and 5.0 V SPI control and status reporting with daisy chain capability
- PWM module using external clock or calibratable internal oscillator with programmable outputs delay management
- Smart over-current shutdown, severe short-circuit, over-temperature protections, with time limited autoretry, and Fail-safe mode, in case of MCU damage
- Output OFF or ON open-load detection compliant to bulbs or LEDs (< 10 mA) and short to battery detection
- Analog current feedback with selectable ratio and board temperature feedback

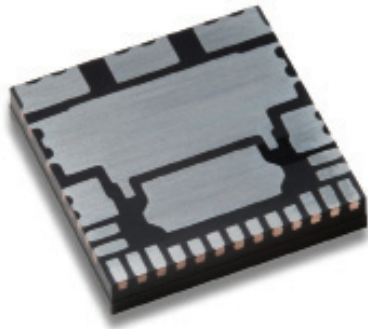

FK SUFFIX (Pb-FREE)
98ARL10596D
24-PIN PQFN

Selector Guide

Part Number (for Tape and Reel, add an R2 suffix)	Temp. Ranges	Features	Package
MC35XS3400CHFK MC35XS3400DHFk	-40 to +125°C	Four—35 mΩ high side switches	24-pin PQFN

Development Tools

Part Number	Description
KIT35XS3400EVBE	Evaluation board Contact Freescale Sales

Documentation

Document Number	Title	Description
MC35XS3400	Quad High Side Switch (Quad 35 mΩ)	Data Sheet
SG1002	Analog, Mixed Signal and Power Management	Selector Guide
SG187	Automotive	Selector Guide
AN3740	Evaluation of Power Dissipation for the eXtreme Switch Devices	Application Note
AN2467	Power Quad Flat No-lead (PQFN) Package	Application Note

Learn More: For more information about Freescale products, please visit www.freescale.com.