

MC7900 Series

1.0 A Negative Voltage Regulators

The MC7900 series of fixed output negative voltage regulators are intended as complements to the popular MC7800 series devices. These negative regulators are available in the same seven-voltage options as the MC7800 devices. In addition, one extra voltage option commonly employed in MECL systems is also available in the negative MC7900 series.

Available in fixed output voltage options from -5.0 V to -24 V , these regulators employ current limiting, thermal shutdown, and safe-area compensation – making them remarkably rugged under most operating conditions. With adequate heatsinking they can deliver output currents in excess of 1.0 A.

- No External Components Required
- Internal Thermal Overload Protection
- Internal Short Circuit Current Limiting
- Output Transistor Safe-Area Compensation
- Available in 2% Voltage Tolerance (See Ordering Information)



ON Semiconductor™

<http://onsemi.com>

**TO-220
T SUFFIX
CASE 221A**

Heatsink surface
connected to Pin 2.

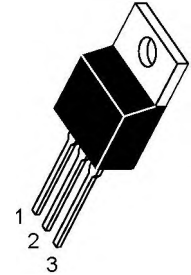

Pin 1. Ground
2. Input
3. Output

**D²PAK
D2T SUFFIX
CASE 936**

Heatsink surface (shown as terminal 4 in
case outline drawing) is connected to Pin 2.

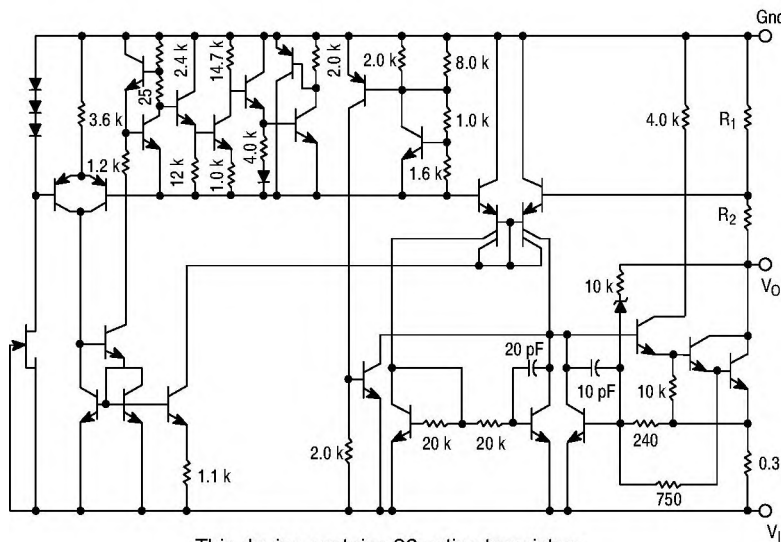
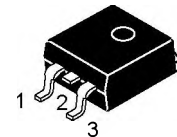

This device contains 26 active transistors.

Figure 1. Representative Schematic Diagram

STANDARD APPLICATION

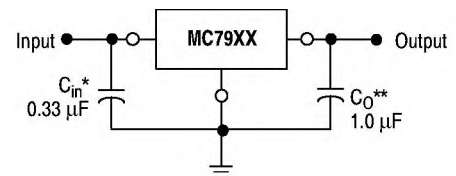

A common ground is required between the input and the output voltages. The input voltage must remain typically 2.0 V above more negative even during the high point of the input ripple voltage.

XX, These two digits of the type number indicate nominal voltage.

* C_{in} is required if regulator is located an appreciable distance from power supply filter.

** C_O improve stability and transient response.

ORDERING INFORMATION

See detailed ordering and shipping information in the package dimensions section on page 204 of this data sheet.

DEVICE MARKING INFORMATION

See general marking information in the device marking section on page 205 of this data sheet.

MC7900 Series

MAXIMUM RATINGS ($T_A = +25^\circ\text{C}$, unless otherwise noted.)

Rating	Symbol	Value	Unit
Input Voltage ($-5.0\text{ V} \geq V_O \geq -18\text{ V}$) (24 V)	V_I	-35 -40	Vdc
Power Dissipation Case 221A $T_A = +25^\circ\text{C}$ Thermal Resistance, Junction-to-Ambient Thermal Resistance, Junction-to-Case Case 936 (D ² PAK) $T_A = +25^\circ\text{C}$ Thermal Resistance, Junction-to-Ambient Thermal Resistance, Junction-to-Case	P_D θ_{JA} θ_{JC} P_D θ_{JA} θ_{JC}	Internally Limited 65 5.0 Internally Limited 70 5.0	W $^\circ\text{C/W}$ $^\circ\text{C/W}$ W $^\circ\text{C/W}$ $^\circ\text{C/W}$
Storage Junction Temperature Range	T_{stg}	-65 to +150	$^\circ\text{C}$
Junction Temperature	T_J	+150	$^\circ\text{C}$

THERMAL CHARACTERISTICS

Characteristics	Symbol	Max	Unit
Thermal Resistance, Junction-to-Ambient	$R_{\theta JA}$	65	$^\circ\text{C/W}$
Thermal Resistance, Junction-to-Case	$R_{\theta JC}$	5.0	$^\circ\text{C/W}$

MC7905C

ELECTRICAL CHARACTERISTICS ($V_I = -10\text{ V}$, $I_O = 500\text{ mA}$, $0^\circ\text{C} < T_J < +125^\circ\text{C}$, unless otherwise noted.)

Characteristics	Symbol	Min	Typ	Max	Unit
Output Voltage ($T_J = +25^\circ\text{C}$)	V_O	-4.8	-5.0	-5.2	Vdc
Line Regulation (Note 1) ($T_J = +25^\circ\text{C}$, $I_O = 100\text{ mA}$) $-7.0\text{ Vdc} \geq V_I \geq -25\text{ Vdc}$ $-8.0\text{ Vdc} \geq V_I \geq -12\text{ Vdc}$ ($T_J = +25^\circ\text{C}$, $I_O = 500\text{ mA}$) $-7.0\text{ Vdc} \geq V_I \geq -25\text{ Vdc}$ $-8.0\text{ Vdc} \geq V_I \geq -12\text{ Vdc}$	Reg_{line}	- - -	7.0 2.0 35 8.0	50 25 100 50	mV
Load Regulation, $T_J = +25^\circ\text{C}$ (Note 1) $5.0\text{ mA} \leq I_O \leq 1.5\text{ A}$ $250\text{ mA} \leq I_O \leq 750\text{ mA}$	Reg_{load}	- -	11 4.0	100 50	mV
Output Voltage $-7.0\text{ Vdc} \geq V_I \geq -20\text{ Vdc}$, $5.0\text{ mA} \leq I_O \leq 1.0\text{ A}$, $P \leq 15\text{ W}$	V_O	-4.75	-	-5.25	Vdc
Input Bias Current ($T_J = +25^\circ\text{C}$)	I_{IB}	-	4.3	8.0	mA
Input Bias Current Change $-7.0\text{ Vdc} \geq V_I \geq -25\text{ Vdc}$ $5.0\text{ mA} \leq I_O \leq 1.5\text{ A}$	ΔI_{IB}	- -	- -	1.3 0.5	mA
Output Noise Voltage ($T_A = +25^\circ\text{C}$, $10\text{ Hz} \leq f \leq 100\text{ kHz}$)	V_n	-	40	-	μV
Ripple Rejection ($I_O = 20\text{ mA}$, $f = 120\text{ Hz}$)	RR	-	70	-	dB
Dropout Voltage $I_O = 1.0\text{ A}$, $T_J = +25^\circ\text{C}$	$V_I - V_O$	-	2.0	-	Vdc
Average Temperature Coefficient of Output Voltage $I_O = 5.0\text{ mA}$, $0^\circ\text{C} \leq T_J \leq +125^\circ\text{C}$	$\Delta V_O / \Delta T$	-	-1.0	-	$\text{mV}/^\circ\text{C}$

1. Load and line regulation are specified at constant junction temperature. Changes in V_O due to heating effects must be taken into account separately. Pulse testing with low duty cycle is used.

MC7900 Series

MC7905AC

ELECTRICAL CHARACTERISTICS ($V_I = -10\text{ V}$, $I_O = 500\text{ mA}$, $0^\circ\text{C} < T_J < +125^\circ\text{C}$, unless otherwise noted.)

Characteristics	Symbol	Min	Typ	Max	Unit
Output Voltage ($T_J = +25^\circ\text{C}$)	V_O	-4.9	-5.0	-5.1	Vdc
Line Regulation (Note 2) -8.0 Vdc $\geq V_I \geq -12\text{ Vdc}$; $I_O = 1.0\text{ A}$, $T_J = +25^\circ\text{C}$ -8.0 Vdc $\geq V_I \geq -12\text{ Vdc}$; $I_O = 1.0\text{ A}$ -7.5 Vdc $\geq V_I \geq -25\text{ Vdc}$; $I_O = 500\text{ mA}$ -7.0 Vdc $\geq V_I \geq -20\text{ Vdc}$; $I_O = 1.0\text{ A}$, $T_J = +25^\circ\text{C}$	Reg_{line}	-	2.0 7.0 7.0 6.0	25 50 50 50	mV
Load Regulation (Note 2) $5.0\text{ mA} \leq I_O \leq 1.5\text{ A}$, $T_J = +25^\circ\text{C}$ $250\text{ mA} \leq I_O \leq 750\text{ mA}$ $5.0\text{ mA} \leq I_O \leq 1.0\text{ A}$	Reg_{load}	-	11 4.0 9.0	100 50 100	mV
Output Voltage -7.5 Vdc $\geq V_I \geq -20\text{ Vdc}$, $5.0\text{ mA} \leq I_O \leq 1.0\text{ A}$, $P \leq 15\text{ W}$	V_O	-4.80	-	-5.20	Vdc
Input Bias Current	I_{IB}	-	4.4	8.0	mA
Input Bias Current Change -7.5 Vdc $\geq V_I \geq -25\text{ Vdc}$ $5.0\text{ mA} \leq I_O \leq 1.0\text{ A}$ $5.0\text{ mA} \leq I_O \leq 1.5\text{ A}$, $T_J = +25^\circ\text{C}$	ΔI_{IB}	-	-	1.3 0.5 0.5	mA
Output Noise Voltage ($T_A = +25^\circ\text{C}$, $10\text{ Hz} \leq f \leq 100\text{ kHz}$)	V_n	-	40	-	μV
Ripple Rejection ($I_O = \text{mA}$, $f = 120\text{ Hz}$)	RR	-	70	-	dB
Dropout Voltage ($I_O = 1.0\text{ A}$, $T_J = +25^\circ\text{C}$)	$V_I - V_O$	-	2.0	-	Vdc
Average Temperature Coefficient of Output Voltage $I_O = 5.0\text{ A}$, $0^\circ\text{C} \leq T_J \leq +125^\circ\text{C}$	$\Delta V_O / \Delta T$	-	-1.0	-	$\text{mV}/^\circ\text{C}$

MC7905.2C

ELECTRICAL CHARACTERISTICS ($V_I = -10\text{ V}$, $I_O = 500\text{ mA}$, $0^\circ\text{C} < T_J < +125^\circ\text{C}$, unless otherwise noted.)

Characteristics	Symbol	Min	Typ	Max	Unit
Output Voltage ($T_J = +25^\circ\text{C}$)	V_O	-5.0	-5.2	-5.4	Vdc
Line Regulation (Note 2) ($T_J = +25^\circ\text{C}$, $I_O = 100\text{ mA}$) -7.2 Vdc $\geq V_I \geq -25\text{ Vdc}$ -8.0 Vdc $\geq V_I \geq -12\text{ Vdc}$ ($T_J = +25^\circ\text{C}$, $I_O = 500\text{ mA}$) -7.2 Vdc $\geq V_I \geq -25\text{ Vdc}$ -8.0 Vdc $\geq V_I \geq -12\text{ Vdc}$	Reg_{line}	-	8.0 2.2 37 8.5	52 27 105 52	mV
Load Regulation, $T_J = +25^\circ\text{C}$ (Note 2) $5.0\text{ mA} \leq I_O \leq 1.5\text{ A}$ $250\text{ mA} \leq I_O \leq 750\text{ mA}$	Reg_{load}	-	12 4.5	105 52	mV
Output Voltage -7.2 Vdc $\geq V_I \geq -20\text{ Vdc}$, $5.0\text{ mA} \leq I_O \leq 1.0\text{ A}$, $P \leq 15\text{ W}$	V_O	-4.95	-	-5.45	Vdc
Input Bias Current ($T_J = +25^\circ\text{C}$)	I_{IB}	-	4.3	8.0	mA
Input Bias Current Change -7.2 Vdc $\geq V_I \geq -25\text{ Vdc}$ $5.0\text{ mA} \leq I_O \leq 1.5\text{ A}$	ΔI_{IB}	-	-	1.3 0.5	mA
Output Noise Voltage ($T_A = +25^\circ\text{C}$, $10\text{ Hz} \leq f \leq 100\text{ kHz}$)	V_n	-	42	-	μV
Ripple Rejection ($I_O = 20\text{ mA}$, $f = 120\text{ Hz}$)	RR	-	68	-	dB
Dropout Voltage ($I_O = 1.0\text{ A}$, $T_J = +25^\circ\text{C}$)	$V_I - V_O$	-	2.0	-	Vdc
Average Temperature Coefficient of Output Voltage $I_O = 5.0\text{ mA}$, $0^\circ\text{C} \leq T_J \leq +125^\circ\text{C}$	$\Delta V_O / \Delta T$	-	-1.0	-	$\text{mV}/^\circ\text{C}$

2. Load and line regulation are specified at constant junction temperature. Changes in V_O due to heating effects must be taken into account separately. Pulse testing with low duty cycle is used.

MC7900 Series

MC7906C

ELECTRICAL CHARACTERISTICS ($V_I = -11\text{ V}$, $I_O = 500\text{ mA}$, $0^\circ\text{C} < T_J < +125^\circ\text{C}$, unless otherwise noted.)

Characteristics	Symbol	Min	Typ	Max	Unit
Output Voltage ($T_J = +25^\circ\text{C}$)	V_O	-5.75	-6.0	-6.25	Vdc
Line Regulation (Note 3) ($T_J = +25^\circ\text{C}$, $I_O = 100\text{ mA}$) -8.0 Vdc $\geq V_I \geq -25\text{ Vdc}$ -9.0 Vdc $\geq V_I \geq -13\text{ Vdc}$ ($T_J = +25^\circ\text{C}$, $I_O = 500\text{ mA}$) -8.0 Vdc $\geq V_I \geq -25\text{ Vdc}$ -9.0 Vdc $\geq V_I \geq -13\text{ Vdc}$	Reg_{line}	-	9.0 3.0	60 30	mV
Load Regulation, $T_J = +25^\circ\text{C}$ (Note 3) $5.0\text{ mA} \leq I_O \leq 1.5\text{ A}$ $250\text{ mA} \leq I_O \leq 750\text{ mA}$	Reg_{load}	-	13 5.0	120 60	mV
Output Voltage -8.0 Vdc $\geq V_I \geq -21\text{ Vdc}$, $5.0\text{ mA} \leq I_O \leq 1.0\text{ A}$, $P \leq 15\text{ W}$	V_O	-5.7	-	-6.3	Vdc
Input Bias Current ($T_J = +25^\circ\text{C}$)	I_{IB}	-	4.3	8.0	mA
Input Bias Current Change -8.0 Vdc $\geq V_I \geq -25\text{ Vdc}$ $5.0\text{ mA} \leq I_O \leq 1.5\text{ A}$	ΔI_{IB}	-	-	1.3 0.5	mA
Output Noise Voltage ($T_A = +25^\circ\text{C}$, $10\text{ Hz} \leq f \leq 100\text{ kHz}$)	V_n	-	45	-	μV
Ripple Rejection ($I_O = 20\text{ mA}$, $f = 120\text{ Hz}$)	RR	-	65	-	dB
Dropout Voltage ($I_O = 1.0\text{ A}$, $T_J = +25^\circ\text{C}$)	$V_I - V_O$	-	2.0	-	Vdc
Average Temperature Coefficient of Output Voltage $I_O = 5.0\text{ A}$, $0^\circ\text{C} \leq T_J \leq +125^\circ\text{C}$	$\Delta V_O / \Delta T$	-	-1.0	-	$\text{mV}/^\circ\text{C}$

MC7908C

ELECTRICAL CHARACTERISTICS ($V_I = -14\text{ V}$, $I_O = 500\text{ mA}$, $0^\circ\text{C} < T_J < +125^\circ\text{C}$, unless otherwise noted.)

Characteristics	Symbol	Min	Typ	Max	Unit
Output Voltage ($T_J = +25^\circ\text{C}$)	V_O	-7.7	-8.0	-8.3	Vdc
Line Regulation (Note 3) ($T_J = +25^\circ\text{C}$, $I_O = 100\text{ mA}$) -10.5 Vdc $\geq V_I \geq -25\text{ Vdc}$ -11 Vdc $\geq V_I \geq -17\text{ Vdc}$ ($T_J = +25^\circ\text{C}$, $I_O = 500\text{ mA}$) -10.5 Vdc $\geq V_I \geq -25\text{ Vdc}$ -11 Vdc $\geq V_I \geq -17\text{ Vdc}$	Reg_{line}	-	12 5.0	80 40	mV
Load Regulation, $T_J = +25^\circ\text{C}$ (Note 3) $5.0\text{ mA} \leq I_O \leq 1.5\text{ A}$ $250\text{ mA} \leq I_O \leq 750\text{ mA}$	Reg_{load}	-	26 9.0	160 80	mV
Output Voltage -10.5 Vdc $\geq V_I \geq -23\text{ Vdc}$, $5.0\text{ mA} \leq I_O \leq 1.0\text{ A}$, $P \leq 15\text{ W}$	V_O	-7.6	-	-8.4	Vdc
Input Bias Current ($T_J = +25^\circ\text{C}$)	I_{IB}	-	4.3	8.0	mA
Input Bias Current Change -10.5 Vdc $\geq V_I \geq -25\text{ Vdc}$ $5.0\text{ mA} \leq I_O \leq 1.5\text{ A}$	ΔI_{IB}	-	-	1.0 0.5	mA
Output Noise Voltage ($T_A = +25^\circ\text{C}$, $10\text{ Hz} \leq f \leq 100\text{ kHz}$)	V_n	-	52	-	μV
Ripple Rejection ($I_O = 20\text{ mA}$, $f = 120\text{ Hz}$)	RR	-	62	-	dB
Dropout Voltage ($I_O = 1.0\text{ A}$, $T_J = +25^\circ\text{C}$)	$V_I - V_O$	-	2.0	-	Vdc
Average Temperature Coefficient of Output Voltage $I_O = 5.0\text{ mA}$, $0^\circ\text{C} \leq T_J \leq +125^\circ\text{C}$	$\Delta V_O / \Delta T$	-	-1.0	-	$\text{mV}/^\circ\text{C}$

3. Load and line regulation are specified at constant junction temperature. Changes in V_O due to heating effects must be taken into account separately. Pulse testing with low duty cycle is used.

MC7900 Series

MC7912C

ELECTRICAL CHARACTERISTICS ($V_I = -19\text{ V}$, $I_O = 500\text{ mA}$, $0^\circ\text{C} < T_J < +125^\circ\text{C}$, unless otherwise noted.)

Characteristics	Symbol	Min	Typ	Max	Unit
Output Voltage ($T_J = +25^\circ\text{C}$)	V_O	-11.5	-12	-12.5	Vdc
Line Regulation (Note 4) ($T_J = +25^\circ\text{C}$, $I_O = 100\text{ mA}$) -14.5 Vdc $\geq V_I \geq -30\text{ Vdc}$ -16 Vdc $\geq V_I \geq -22\text{ Vdc}$ ($T_J = +25^\circ\text{C}$, $I_O = 500\text{ mA}$) -14.5 Vdc $\geq V_I \geq -30\text{ Vdc}$ -16 Vdc $\geq V_I \geq -22\text{ Vdc}$	Reg_{line}	-	13 6.0	120 60	mV
Load Regulation, $T_J = +25^\circ\text{C}$ (Note 4) $5.0\text{ mA} \leq I_O \leq 1.5\text{ A}$ $250\text{ mA} \leq I_O \leq 750\text{ mA}$	Reg_{load}	-	46 17	240 120	mV
Output Voltage -14.5 Vdc $\geq V_I \geq -27\text{ Vdc}$, $5.0\text{ mA} \leq I_O \leq 1.0\text{ A}$, $P \leq 15\text{ W}$	V_O	-11.4	-	-12.6	Vdc
Input Bias Current ($T_J = +25^\circ\text{C}$)	I_{IB}	-	4.4	8.0	mA
Input Bias Current Change -14.5 Vdc $\geq V_I \geq -30\text{ Vdc}$ $5.0\text{ mA} \leq I_O \leq 1.5\text{ A}$	ΔI_{IB}	-	-	1.0 0.5	mA
Output Noise Voltage ($T_A = +25^\circ\text{C}$, $10\text{ Hz} \leq f \leq 100\text{ kHz}$)	V_n	-	75	-	μV
Ripple Rejection ($I_O = 20\text{ mA}$, $f = 120\text{ Hz}$)	RR	-	61	-	dB
Dropout Voltage ($I_O = 1.0\text{ A}$, $T_J = +25^\circ\text{C}$)	$V_I - V_O$	-	2.0	-	Vdc
Average Temperature Coefficient of Output Voltage $I_O = 5.0\text{ mA}$, $0^\circ\text{C} \leq T_J \leq +125^\circ\text{C}$	$\Delta V_O / \Delta T$	-	-1.0	-	$\text{mV}/^\circ\text{C}$

MC7912AC

ELECTRICAL CHARACTERISTICS ($V_I = -19\text{ V}$, $I_O = 500\text{ mA}$, $0^\circ\text{C} < T_J < +125^\circ\text{C}$, unless otherwise noted.)

Characteristics	Symbol	Min	Typ	Max	Unit
Output Voltage ($T_J = +25^\circ\text{C}$)	V_O	-11.75	-12	-12.25	Vdc
Line Regulation (Note 4) -16 Vdc $\geq V_I \geq -22\text{ Vdc}$; $I_O = 1.0\text{ A}$, $T_J = +25^\circ\text{C}$ -16 Vdc $\geq V_I \geq -22\text{ Vdc}$; $I_O = 1.0\text{ A}$ -14.8 Vdc $\geq V_I \geq -30\text{ Vdc}$; $I_O = 500\text{ mA}$ -14.5 Vdc $\geq V_I \geq -27\text{ Vdc}$; $I_O = 1.0\text{ A}$, $T_J = +25^\circ\text{C}$	Reg_{line}	-	6.0 24 24 13	60 120 120 120	mV
Load Regulation (Note 4) $5.0\text{ mA} \leq I_O \leq 1.5\text{ A}$, $T_J = +25^\circ\text{C}$ $250\text{ mA} \leq I_O \leq 750\text{ mA}$ $5.0\text{ mA} \leq I_O \leq 1.0\text{ A}$	Reg_{load}	-	46 17 35	150 75 150	mV
Output Voltage -14.8 Vdc $\geq V_I \geq -27\text{ Vdc}$, $5.0\text{ mA} \leq I_O \leq 1.0\text{ A}$, $P \leq 15\text{ W}$	V_O	-11.5	-	-12.5	Vdc
Input Bias Current	I_{IB}	-	4.4	8.0	mA
Input Bias Current Change -15 Vdc $\geq V_I \geq -30\text{ Vdc}$ $5.0\text{ mA} \leq I_O \leq 1.0\text{ A}$ $5.0\text{ mA} \leq I_O \leq 1.5\text{ A}$, $T_J = +25^\circ\text{C}$	ΔI_{IB}	-	-	0.8 0.5 0.5	mA
Output Noise Voltage ($T_A = +25^\circ\text{C}$, $10\text{ Hz} \leq f \leq 100\text{ kHz}$)	V_n	-	75	-	μV
Ripple Rejection ($I_O = 20\text{ mA}$, $f = 120\text{ Hz}$)	RR	-	61	-	dB
Dropout Voltage ($I_O = 1.0\text{ A}$, $T_J = +25^\circ\text{C}$)	$V_I - V_O$	-	2.0	-	Vdc
Average Temperature Coefficient of Output Voltage $I_O = 5.0\text{ A}$, $0^\circ\text{C} \leq T_J \leq +125^\circ\text{C}$	$\Delta V_O / \Delta T$	-	-1.0	-	$\text{mV}/^\circ\text{C}$

4. Load and line regulation are specified at constant junction temperature. Changes in V_O due to heating effects must be taken into account separately. Pulse testing with low duty cycle is used.

MC7900 Series

MC7915C

ELECTRICAL CHARACTERISTICS ($V_I = -23\text{ V}$, $I_O = 500\text{ mA}$, $0^\circ\text{C} < T_J < +125^\circ\text{C}$, unless otherwise noted.)

Characteristics	Symbol	Min	Typ	Max	Unit
Output Voltage ($T_J = +25^\circ\text{C}$)	V_O	-14.4	-15	-15.6	Vdc
Line Regulation (Note 5) ($T_J = +25^\circ\text{C}$, $I_O = 100\text{ mA}$) -17.5 Vdc $\geq V_I \geq -30\text{ Vdc}$ -20 Vdc $\geq V_I \geq -26\text{ Vdc}$ ($T_J = +25^\circ\text{C}$, $I_O = 500\text{ mA}$) -17.5 Vdc $\geq V_I \geq -30\text{ Vdc}$ -20 Vdc $\geq V_I \geq -26\text{ Vdc}$	Reg_{line}	-	14 6.0	150 75	mV
Load Regulation, $T_J = +25^\circ\text{C}$ (Note 5) $5.0\text{ mA} \leq I_O \leq 1.5\text{ A}$ $250\text{ mA} \leq I_O \leq 750\text{ mA}$	Reg_{load}	-	68 25	300 150	mV
Output Voltage -17.5 Vdc $\geq V_I \geq -30\text{ Vdc}$, $5.0\text{ mA} \leq I_O \leq 1.0\text{ A}$, $P \leq 15\text{ W}$	V_O	-14.25	-	-15.75	Vdc
Input Bias Current ($T_J = +25^\circ\text{C}$)	I_{IB}	-	4.4	8.0	mA
Input Bias Current Change -17.5 Vdc $\geq V_I \geq -30\text{ Vdc}$ $5.0\text{ mA} \leq I_O \leq 1.5\text{ A}$	ΔI_{IB}	-	-	1.0 0.5	mA
Output Noise Voltage ($T_A = +25^\circ\text{C}$, $10\text{ Hz} \leq f \leq 100\text{ kHz}$)	V_n	-	90	-	μV
Ripple Rejection ($I_O = 20\text{ mA}$, $f = 120\text{ Hz}$)	RR	-	60	-	dB
Dropout Voltage ($I_O = 1.0\text{ A}$, $T_J = +25^\circ\text{C}$)	$V_I - V_O$	-	2.0	-	Vdc
Average Temperature Coefficient of Output Voltage $I_O = 5.0\text{ A}$, $0^\circ\text{C} \leq T_J \leq +125^\circ\text{C}$	$\Delta V_O / \Delta T$	-	-1.0	-	$\text{mV}/^\circ\text{C}$

MC7915AC

ELECTRICAL CHARACTERISTICS ($V_I = -23\text{ V}$, $I_O = 500\text{ mA}$, $0^\circ\text{C} < T_J < +125^\circ\text{C}$, unless otherwise noted.)

Characteristics	Symbol	Min	Typ	Max	Unit
Output Voltage ($T_J = +25^\circ\text{C}$)	V_O	-14.7	-15	-15.3	Vdc
Line Regulation (Note 5) -20 Vdc $\geq V_I \geq -26\text{ Vdc}$, $I_O = 1.0\text{ A}$, $T_J = +25^\circ\text{C}$ -20 Vdc $\geq V_I \geq -26\text{ Vdc}$, $I_O = 1.0\text{ A}$, -17.9 Vdc $\geq V_I \geq -30\text{ Vdc}$, $I_O = 500\text{ mA}$ -17.5 Vdc $\geq V_I \geq -30\text{ Vdc}$, $I_O = 1.0\text{ A}$, $T_J = +25^\circ\text{C}$	Reg_{line}	-	27 57 57 57	75 150 150 150	mV
Load Regulation (Note 5) $5.0\text{ mA} \leq I_O \leq 1.5\text{ A}$, $T_J = +25^\circ\text{C}$ $250\text{ mA} \leq I_O \leq 750\text{ mA}$ $5.0\text{ mA} \leq I_O \leq 1.0\text{ A}$	Reg_{load}	-	68 25 40	150 75 150	mV
Output Voltage -17.9 Vdc $\geq V_I \geq -30\text{ Vdc}$, $5.0\text{ mA} \leq I_O \leq 1.0\text{ A}$, $P \leq 15\text{ W}$	V_O	-14.4	-	-15.6	Vdc
Input Bias Current	I_{IB}	-	4.4	8.0	mA
Input Bias Current Change -17.5 Vdc $\geq V_I \geq -30\text{ Vdc}$ $5.0\text{ mA} \leq I_O \leq 1.0\text{ A}$ $5.0\text{ mA} \leq I_O \leq 1.5\text{ A}$, $T_J = +25^\circ\text{C}$	ΔI_{IB}	-	-	0.8 0.5 0.5	mA
Output Noise Voltage ($T_A = +25^\circ\text{C}$, $10\text{ Hz} \leq f \leq 100\text{ kHz}$)	V_n	-	90	-	μV
Ripple Rejection ($I_O = 20\text{ mA}$, $f = 120\text{ Hz}$)	RR	-	60	-	dB
Dropout Voltage ($I_O = 1.0\text{ A}$, $T_J = +25^\circ\text{C}$)	$V_I - V_O$	-	2.0	-	Vdc
Average Temperature Coefficient of Output Voltage $I_O = 5.0\text{ mA}$, $0^\circ\text{C} \leq T_J \leq +125^\circ\text{C}$	$\Delta V_O / \Delta T$	-	-1.0	-	$\text{mV}/^\circ\text{C}$

5. Load and line regulation are specified at constant junction temperature. Changes in V_O due to heating effects must be taken into account separately. Pulse testing with low duty cycle is used.

MC7900 Series

MC7918C

ELECTRICAL CHARACTERISTICS ($V_I = -27\text{ V}$, $I_O = 500\text{ mA}$, $0^\circ\text{C} < T_J < +125^\circ\text{C}$, unless otherwise noted.)

Characteristics	Symbol	Min	Typ	Max	Unit
Output Voltage ($T_J = +25^\circ\text{C}$)	V_O	-17.3	-18	-18.7	Vdc
Line Regulation (Note 6) ($T_J = +25^\circ\text{C}$, $I_O = 100\text{ mA}$) -21 Vdc $\geq V_I \geq -33\text{ Vdc}$ -24 Vdc $\geq V_I \geq -30\text{ Vdc}$ ($T_J = +25^\circ\text{C}$, $I_O = 500\text{ mA}$) -21 Vdc $\geq V_I \geq -33\text{ Vdc}$ -24 Vdc $\geq V_I \geq -30\text{ Vdc}$	Reg_{line}	-	25 10	180 90	mV
Load Regulation, $T_J = +25^\circ\text{C}$ (Note 6) $5.0\text{ mA} \leq I_O \leq 1.5\text{ A}$ $250\text{ mA} \leq I_O \leq 750\text{ mA}$	Reg_{load}	-	110 55	360 180	mV
Output Voltage -21 Vdc $\geq V_I \geq -33\text{ Vdc}$, $5.0\text{ mA} \leq I_O \leq 1.0\text{ A}$, $P \leq 15\text{ W}$	V_O	-17.1	-	-18.9	Vdc
Input Bias Current ($T_J = +25^\circ\text{C}$)	I_{IB}	-	4.5	8.0	mA
Input Bias Current Change -21 Vdc $\geq V_I \geq -33\text{ Vdc}$ $5.0\text{ mA} \leq I_O \leq 1.5\text{ A}$	ΔI_{IB}	-	-	1.0 0.5	mA
Output Noise Voltage ($T_A = +25^\circ\text{C}$, $10\text{ Hz} \leq f \leq 100\text{ kHz}$)	V_n	-	110	-	μV
Ripple Rejection ($I_O = 20\text{ mA}$, $f = 120\text{ Hz}$)	RR	-	59	-	dB
Dropout Voltage ($I_O = 1.0\text{ A}$, $T_J = +25^\circ\text{C}$)	$V_I - V_O$	-	2.0	-	Vdc
Average Temperature Coefficient of Output Voltage $I_O = 5.0\text{ mA}$, $0^\circ\text{C} \leq T_J \leq +125^\circ\text{C}$	$\Delta V_O / \Delta T$	-	-1.0	-	$\text{mV}/^\circ\text{C}$

MC7924C

ELECTRICAL CHARACTERISTICS ($V_I = -33\text{ V}$, $I_O = 500\text{ mA}$, $0^\circ\text{C} < T_J < +125^\circ\text{C}$, unless otherwise noted.)

Characteristics	Symbol	Min	Typ	Max	Unit
Output Voltage ($T_J = +25^\circ\text{C}$)	V_O	-23	-24	-25	Vdc
Line Regulation (Note 6) ($T_J = +25^\circ\text{C}$, $I_O = 100\text{ mA}$) -27 Vdc $\geq V_I \geq -38\text{ Vdc}$ -30 Vdc $\geq V_I \geq -36\text{ Vdc}$ ($T_J = +25^\circ\text{C}$, $I_O = 500\text{ mA}$) -27 Vdc $\geq V_I \geq -38\text{ Vdc}$ -30 Vdc $\geq V_I \geq -36\text{ Vdc}$	Reg_{line}	-	31 14	240 120	mV
Load Regulation, $T_J = +25^\circ\text{C}$ (Note 6) $5.0\text{ mA} \leq I_O \leq 1.5\text{ A}$ $250\text{ mA} \leq I_O \leq 750\text{ mA}$	Reg_{load}	-	150 85	480 240	mV
Output Voltage -27 Vdc $\geq V_I \geq -38\text{ Vdc}$, $5.0\text{ mA} \leq I_O \leq 1.0\text{ A}$, $P \leq 15\text{ W}$	V_O	-22.8	-	-25.2	Vdc
Input Bias Current ($T_J = +25^\circ\text{C}$)	I_{IB}	-	4.6	8.0	mA
Input Bias Current Change -27 Vdc $\geq V_I \geq -38\text{ Vdc}$ $5.0\text{ mA} \leq I_O \leq 1.5\text{ A}$	ΔI_{IB}	-	-	1.0 0.5	mA
Output Noise Voltage ($T_A = +25^\circ\text{C}$, $10\text{ Hz} \leq f \leq 100\text{ kHz}$)	V_n	-	170	-	μV
Ripple Rejection ($I_O = 20\text{ mA}$, $f = 120\text{ Hz}$)	RR	-	56	-	dB
Dropout Voltage ($I_O = 1.0\text{ A}$, $T_J = +25^\circ\text{C}$)	$V_I - V_O$	-	2.0	-	Vdc
Average Temperature Coefficient of Output Voltage $I_O = 5.0\text{ mA}$, $0^\circ\text{C} \leq T_J \leq +125^\circ\text{C}$	$\Delta V_O / \Delta T$	-	-1.0	-	$\text{mV}/^\circ\text{C}$

6. Load and line regulation are specified at constant junction temperature. Changes in V_O due to heating effects must be taken into account separately. Pulse testing with low duty cycle is used.

MC7900 Series

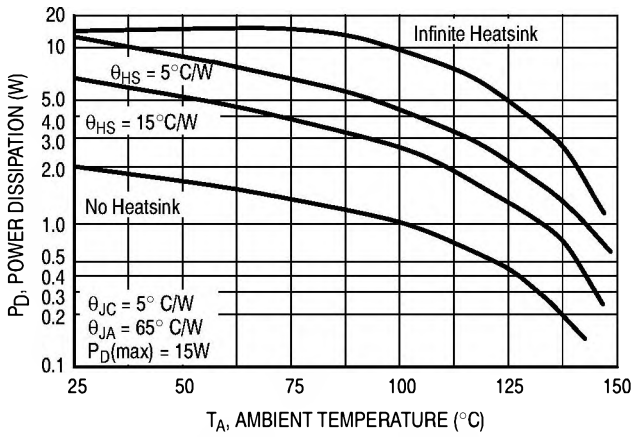

Figure 2. Worst Case Power Dissipation as a Function of Ambient Temperature

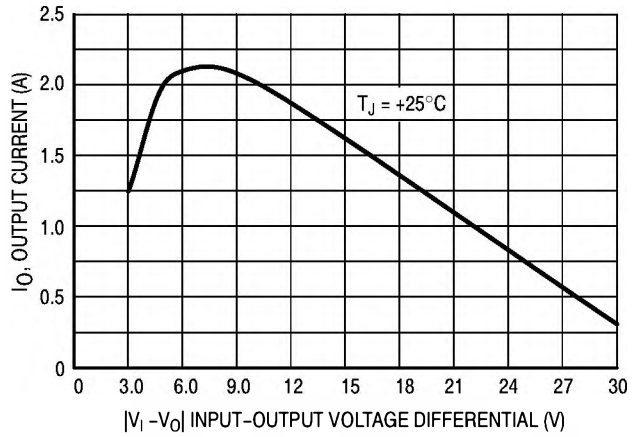

Figure 3. Peak Output Current as a Function of Input-Output Differential Voltage

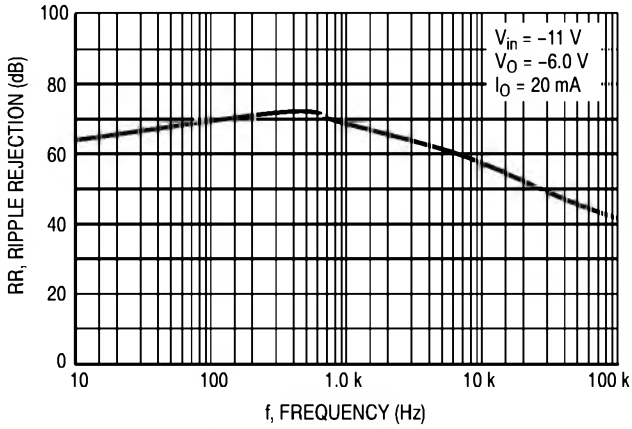

Figure 4. Ripple Rejection as a Function of Frequency

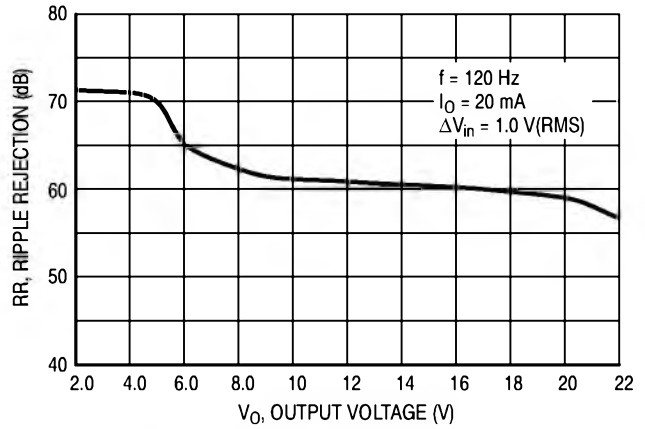

Figure 5. Ripple Rejection as a Function of Output Voltage

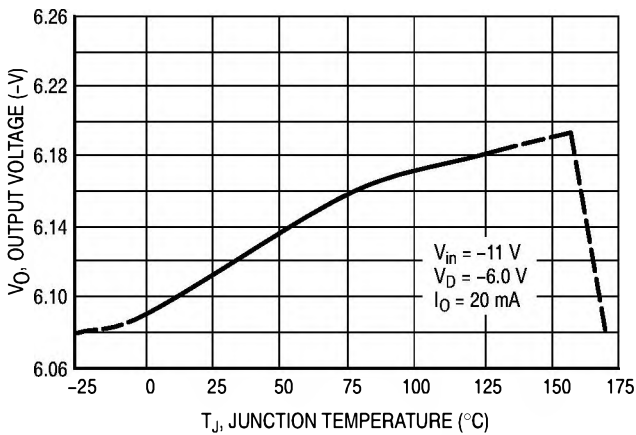

Figure 6. Output Voltage as a Function of Junction Temperature

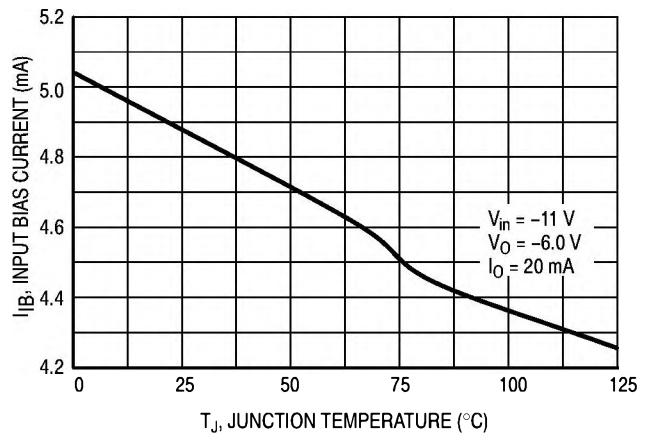

Figure 7. Quiescent Current as a Function of Temperature

MC7900 Series

APPLICATIONS INFORMATION

Design Considerations

The MC7900 Series of fixed voltage regulators are designed with Thermal overload Protection that shuts down the circuit when subjected to an excessive power overload condition. Internal Short Circuit Protection that limits the maximum current the circuit will pass, and Output Transistor Safe-Area Compensation that reduces the output short circuit current as the voltage across the pass transistor is increased.

In many low current applications, compensation capacitors are not required. However, it is recommended that the regulator input be bypassed with a capacitor if the regulator is connected to the power supply filter with long wire lengths, or if the output load capacitance is large. An input bypass capacitor should be selected to provide good high-frequency characteristics to insure stable operation under all load conditions. A 0.33 μF or larger tantalum, mylar, or other capacitor having low internal impedance at high frequencies should be chosen. The capacitor chosen should have an equivalent series resistance of less than 0.7 Ω . The bypass capacitor should be mounted with the shortest possible leads directly across the regulators input terminals. Normally good construction techniques should be

used to minimize ground loops and lead resistance drops since the regulator has no external sense lead. Bypassing the output is also recommended.

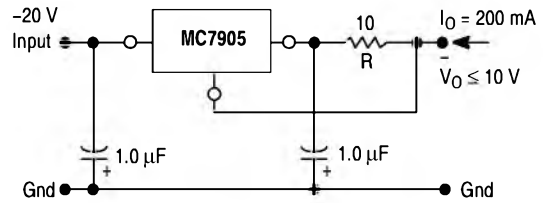

The MC7905, -5.0 V regulator can be used as a constant current source when connected as above. The output current is the sum of resistor R current and quiescent bias current as follows.

$$I_O = \frac{5.0 \text{ V}}{R} + I_B$$

The quiescent current for this regulator is typically 4.3 mA. The 5.0 V regulator was chosen to minimize dissipation and to allow the output voltage to operate to within 6.0 V below the input voltage.

Figure 8. Current Regulator

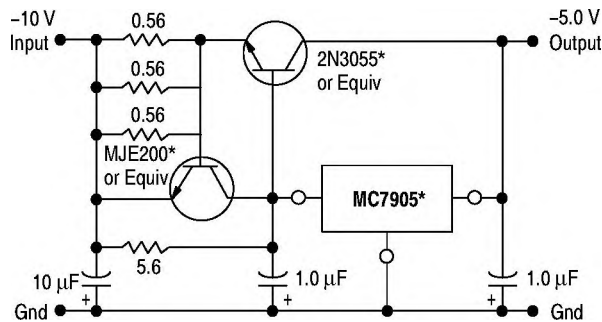

*Mounted on heatsink.

When a boost transistor is used, short circuit currents are equal to the sum of the series pass and regulator limits, which are measured at 3.2 A and 1.8 A respectively in this case. Series pass limiting is approximately equal to 0.6 V/R_{SC}. Operation beyond this point to the peak current capability of the MC7905C is possible if the regulator is mounted on a heatsink; otherwise thermal shutdown will occur when the additional load current is picked up by the regulator.

Figure 9. Current Boost Regulator
(-5.0 V @ 4.0 A, with 5.0 A Current Limiting)

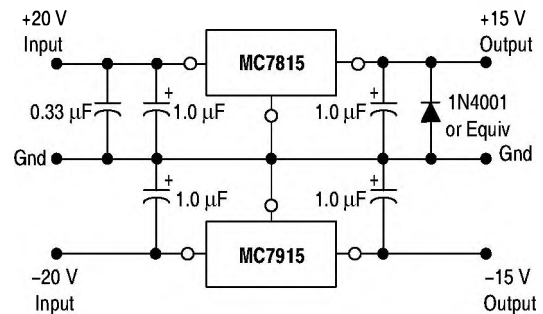

The MC7815 and MC7915 positive and negative regulators may be connected as shown to obtain a dual power supply for operational amplifiers. A clamp diode should be used at the output of the MC7815 to prevent potential latch-up problems whenever the output of the positive regulator (MC7815) is drawn below ground with an output current greater than 200 mA.

Figure 10. Operational Amplifier Supply
(±15 @ 1.0 A)

MC7900 Series

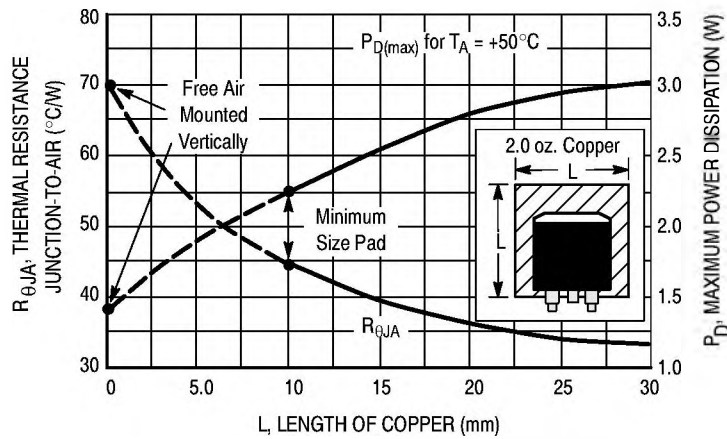

Figure 11. D²PAK Thermal Resistance and Maximum Power Dissipation versus P.C.B. Copper Length

DEFINITIONS

Line Regulation – The change in output voltage for a change in the input voltage. The measurement is made under conditions of low dissipation or by using pulse techniques such that the average chip temperature is not significantly affected.

Load Regulation – The change in output voltage for a change in load current at constant chip temperature.

Maximum Power Dissipation – The maximum total device dissipation for which the regulator will operate within specifications.

Input Bias Current – That part of the input current that is not delivered to the load.

Output Noise Voltage – The rms AC voltage at the output, with constant load and no input ripple, measured over a specified frequency range.

Long Term Stability – Output voltage stability under accelerated life test conditions with the maximum rated voltage listed in the devices' electrical characteristics and maximum power dissipation.

MC7900 Series

ORDERING INFORMATION

Device	Nominal Output Voltage	Output Voltage Tolerance	Package	Operating Temperature Range	Shipping
MC7905ACD2T	5.0 V	2%	D ² PAK	T _J = 0° to +125°C	50 Units/Rail
MC7905ACD2TR4		2%	D ² PAK		800 Tape & Reel
MC7905CD2T		4%	D ² PAK		50 Units/Rail
MC7905CD2TR4		4%	D ² PAK		800 Tape & Reel
MC7905ACT		2%	TO-220		50 Units/Rail
MC7905CT		4%	TO-220		50 Units/Rail
MC7905BD2T		4%	D ² PAK	T _J = -40° to +125°C	50 Units/Rail
MC7905BD2TR4		4%	D ² PAK		800 Tape & Reel
MC7905BT		4%	TO-220		50 Units/Rail
MC7905.2CT	5.2 V	4%	TO-220	T _J = 0° to +125°C	50 Units/Rail
MC7906CD2T	6.0 V	4%	D ² PAK		50 Units/Rail
MC7906CT		4%	TO-220		50 Units/Rail
MC7908CD2T	8.0 V	4%	D ² PAK		50 Units/Rail
MC7908CD2TR4		4%	D ² PAK		800 Tape & Reel
MC7908ACT		2%	TO-220		50 Units/Rail
MC7908CT		4%	TO-220		50 Units/Rail
MC7912ACD2T	12 V	2%	D ² PAK		50 Units/Rail
MC7912ACD2TR4		2%	D ² PAK		800 Tape & Reel
MC7912CD2T		4%	D ² PAK		50 Units/Rail
MC7912CD2TR4		4%	D ² PAK		800 Tape & Reel
MC7912ACT		2%	TO-220		50 Units/Rail
MC7912CT		4%	TO-220	50 Units/Rail	
MC7912BD2T		4%	D ² PAK	T _J = -40° to +125°C	50 Units/Rail
MC7912BD2TR4		4%	D ² PAK		800 Tape & Reel
MC7912BT		4%	TO-220		50 Units/Rail
MC7915ACD2T	15 V	2%	D ² PAK	T _J = 0° to +125°C	50 Units/Rail
MC7915CD2T		4%	D ² PAK		50 Units/Rail
MC7915CD2TR4		4%	D ² PAK		800 Tape & Reel
MC7915ACT		2%	TO-220		50 Units/Rail
MC7915CT		4%	TO-220	50 Units/Rail	
MC7915BD2T		4%	D ² PAK	T _J = -40° to +125°C	50 Units/Rail
MC7915BT		4%	TO-220		50 Units/Rail
MC7918CT	18 V	4%	TO-220	T _J = 0° to +125°C	50 Units/Rail
MC7924CD2T	24 V	4%	D ² PAK		50 Units/Rail
MC7924CT		4%	TO-220		50 Units/Rail
MC7924BT		4%	TO-220		T _J = -40° to +125°C

MC7900 Series

MARKING DIAGRAMS

TO-220 T SUFFIX CASE 221A

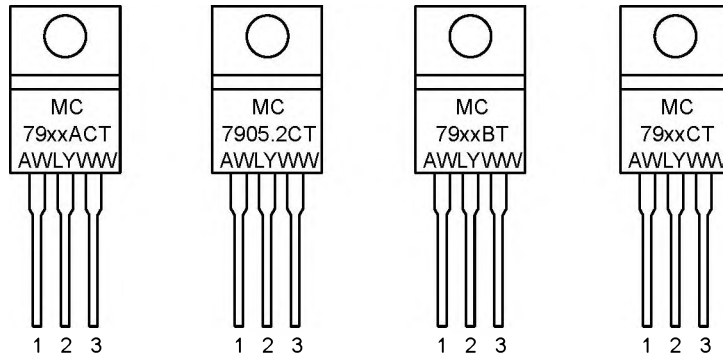

D²PAK D2T SUFFIX CASE 936

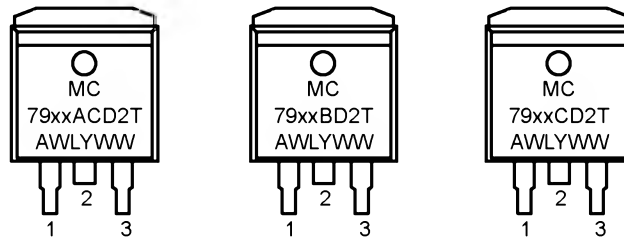

xx = Nominal Voltage
A = Assembly Location
WL = Wafer Lot
Y = Year
WW = Work Week