

# Advance Information

## Integral Alternator Regulator

The MCCF33095 (Flip-Chip) and MC33095 (Surface Mount) are regulator control integrated circuits designed for use in automotive 12 V alternator charging systems. Few external components are required for full system implementation. These devices provide control for a broad range of 12 V alternator charging systems when used in conjunction with the appropriate Motorola Power Darlington transistor to control the field current of the specific alternator.

Both versions have internal detection and protection features to withstand extreme electrical variations encountered in harsh automotive environments. Flip-Chip Technology allows the MCCF33095 to operate at higher ambient temperatures than the surface mount version in addition to withstanding severe vibration and thermal shock with a high degree of reliability.

- Constant Frequency with Variable Duty Cycle Operation
- Adjusts System Charging to Compensate for Changes in Ambient Temperature
- Slew Rate Control to Reduce EMI
- Lamp Pin to Indicate Abnormal Operating Conditions
- Shorted Field Protection
- Resumes Normal Operation Once Fault Condition Ceases
- Operation from  $-40^{\circ}\text{C}$  to  $170^{\circ}\text{C}$  for Flip-Chip and  $-40^{\circ}\text{C}$  to  $125^{\circ}\text{C}$  for SO-14
- Surface Mount or Solder Bump Processed Flip-Chip Assembly Versions

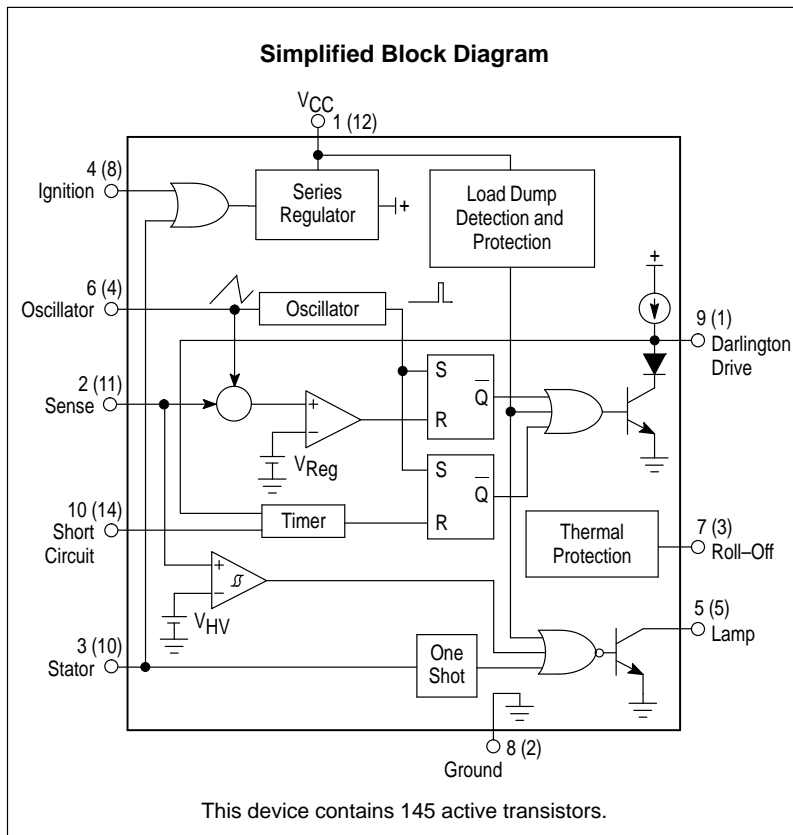

## MCCF33095 MC33095

### INTEGRAL ALTERNATOR REGULATOR

#### SEMICONDUCTOR TECHNICAL DATA

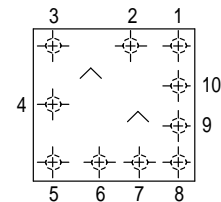

#### FLIP-CHIP CONFIGURATION

(Backside View)

Back marking is oriented as shown

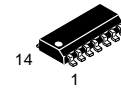

**D SUFFIX**  
PLASTIC PACKAGE  
CASE 751A  
(SO-14)

Bump	Function	SO-14 (Note 1)
1	VCC	(12)
2	Sense	(11)
3	Stator	(10)
4	Ignition	(8)
5	Lamp	(5)
6	Oscillator	(4)
7	Roll-Off	(3)(Note 2)
8	Ground	(2)
9	Darlington Drive	(1)
10	Short Circuit	(14)

**NOTES:** 1. No connections to Pins 3, 6, 7, 9 and 13.  
2. Connected to ground internal to package.

#### ORDERING INFORMATION

Device	Operating Temperature Range	Package
MCCF33095	$T_A = -40^{\circ}$ to $+170^{\circ}\text{C}$	Flip-Chip
MC33095D	$T_A = -40^{\circ}$ to $+125^{\circ}\text{C}$	SO-14

# MCCF33095 MC33095

## MAXIMUM RATINGS (Notes 1 and 3)

Rating	Symbol	Value	Unit
Steady State $V_{CC}$ , $V_{IGN}$ , $V_{STA}$	–	9.0 to 24	V
$V_{CC}$ and $V_{IGN}$ Transient	–	80	V
Bump Shear Strength (Flip-Chip)	–	8.0	Grams/Bump
Thermal Characteristics (Thermal Resistance) Junction-to-Substrate (Flip-Chip) Junction-to-Ambient (SO-14)	$R_{\theta JS}$ $R_{\theta JA}$	29 145	$^{\circ}C/W$
Junction Temperature Flip-Chip SO-14	$T_J$	170 150	$^{\circ}C$
Operating Ambient Temperature Range Flip-Chip SO-14	$T_A$	-40 to +170 -40 to +125	$^{\circ}C$

**ELECTRICAL CHARACTERISTICS** (Limit values are given for  $-40^{\circ}C \leq T_A \leq 150^{\circ}C$  (Flip-Chip),  $-40^{\circ}C \leq T_A \leq 125^{\circ}C$  (SO-14) and typical values represent approximate mean value at  $T_A = 25^{\circ}C$ . Oscillator, Roll-Off, Ground, Short Circuit = 0 V, and  $12 V \leq V_{CC}$ , Sense, Stator, Ignition  $\leq 16 V$ , unless otherwise specified.)

Characteristic	Symbol	Min	Typ	Max	Unit
----------------	--------	-----	-----	-----	------

### SUPPLY ( $V_{CC}$ )

Supply Current Disabled (Ignition = 0.5 V, Stator = 5.0 V) Enabled ( $V_{CC}$ , Sense = 17 V, Ignition = 1.4 V)	$I_{CC}$	-50 0	0.2 3.9	300 25	$\mu A$ mA
Darlington Drive Overvoltage Disable Threshold ( $V_{CC}$ , Ignition, Short Circuit = 19 V to 29 V Ramp, Stator = 10 V) Hysteresis ( $V_{CC}$ , Stator, Ignition, Short Circuit = 29 V to 19 V Ramp)	$V_{CODD}$ $V_{CODDH}$	19 –	26 4.2	28.5 –	V
Lamp Overvoltage Disable Threshold ( $V_{CC}$ , Stator, Ignition, Short Circuit = 19 V to 29 V Ramp) Hysteresis	$V_{COL}$ $V_{COLH}$	19 –	22.3 0.3	29.5 –	V

### SENSE

Sense Current (Oscillator = 2.0 V)	$I_{SNS}$	-10	0.6	10	$\mu A$
Calibration Voltage (50% Duty Cycle) (Note 5)	$V_R$	12.25	14.6	17.5	V
Lamp Comparator Detect Threshold	$V_{SCD}$	–	16.3	–	V
Proportional Control Range	$M_V$	50	187.4	350	mV
Lamp Comparator Reset Threshold	$V_{HV}$	15.4	15.9	16.4	V
Lamp Hysteresis	$V_{HYS}$	20	416.6	600	mV

### STATOR

Propagation Delay (Lamp-to-High, Stator = 15 V to 6.0 V)	$t_{STA}$	6.0	59.4	600	ms
Reset Threshold Voltage (Lamp-to-Low, Stator = 5.0 V to 11 V)	$V_{IH}$	6.0	8.8	11	V
Input Current (Sense = 18 V, Oscillator = 2.0 V)	$I_{STA}$	-10	1.5	10	$\mu A$

### LAMP

Saturation Voltage (Lamp = 14 mA)	$V_{OLL}$	0	111.8	350	mV
Leakage Current (Sense = 1.0 V, Lamp = 2.5 V)	$I_{OHL}$	-50	0.8	50	$\mu A$
Saturation Voltage ( $V_{CC}$ , Sense, Stator, Ignition = 30 V, Lamp = 20 mA)	$V_{OOLL}$	0	147.4	350	mV

- NOTES:**
- $V_{CC}$  applied through a 250  $\Omega$  resistor.
  - Sense input applied through a 100 k $\Omega$  and 50 k $\Omega$  resistor divider to generate one-third  $V_{bat}$ .
  - Stator and Ignition inputs applied through a 20 k $\Omega$  resistor.
  - Short Circuit input applied through a 30 k $\Omega$  resistor.
  - Oscillator pin connected in series with 0.022  $\mu F$  capacitor to ground.

# MCCF33095 MC33095

**ELECTRICAL CHARACTERISTICS (continued)** (Limit values are given for  $-40^{\circ}\text{C} \leq T_A \leq 150^{\circ}\text{C}$  (Flip-Chip),  $-40^{\circ}\text{C} \leq T_A \leq 125^{\circ}\text{C}$  (SO-14) and typical values represent approximate mean value at  $T_A = 25^{\circ}\text{C}$ . Oscillator, Roll-Off, Ground, Short Circuit = 0 V, and  $12\text{ V} \leq V_{CC}$ , Sense, Stator, Ignition  $\leq 16\text{ V}$ , unless otherwise specified.)

## DARLINGTON DRIVE

Source Current (Pins $V_{CC}$ , Sense, Ignition = 9.0 V, Darlington Drive = V across Power Darlington)	$I_{OHDD}$	4.0	7.6	20	mA
Saturation Voltage (Sense = 18 V, Oscillator = 2.0 V, Darlington Drive = $-100\ \mu\text{A}$ )	$V_{OLDD}$	0	300.1	350	mV
Minimum "On" Time (Sense = 18 V) (Note 5)	$t_{DD}$	200	697.8	700	$\mu\text{s}$
Frequency (Note 5)	$F_{OSC}$	75	174.7	325	Hz
Minimum Duty Cycle (Sense = 18 V) (Note 5)	$DC_{DD}$	4.0	12.2	13	%
Rise Time (10% to 90%) (Note 5)	$t_r$	10	21.4	50	$\mu\text{s}$
Fall Time (90% to 10%) (Note 5)	$t_f$	10	23.7	50	$\mu\text{s}$

## SHORT CIRCUIT

Duty Cycle (Note 5)	$DC_{SC}$	1.0	1.7	5.0	%
"On" Time (Short Circuit High, Short Circuit = 8.0 V) (Note 5)	$PW_{SC}$	60	99	660	$\mu\text{s}$

- NOTES:**
- $V_{CC}$  applied through a  $250\ \Omega$  resistor.
  - Sense input applied through a  $100\ \text{k}\Omega$  and  $50\ \text{k}\Omega$  resistor divider to generate one-third  $V_{bat}$ .
  - Stator and Ignition inputs applied through a  $20\ \text{k}\Omega$  resistor.
  - Short Circuit input applied through a  $30\ \text{k}\Omega$  resistor.
  - Oscillator pin connected in series with  $0.022\ \mu\text{F}$  capacitor to ground.

**Figure 1. Flip-Chip Mechanical Dimensions**

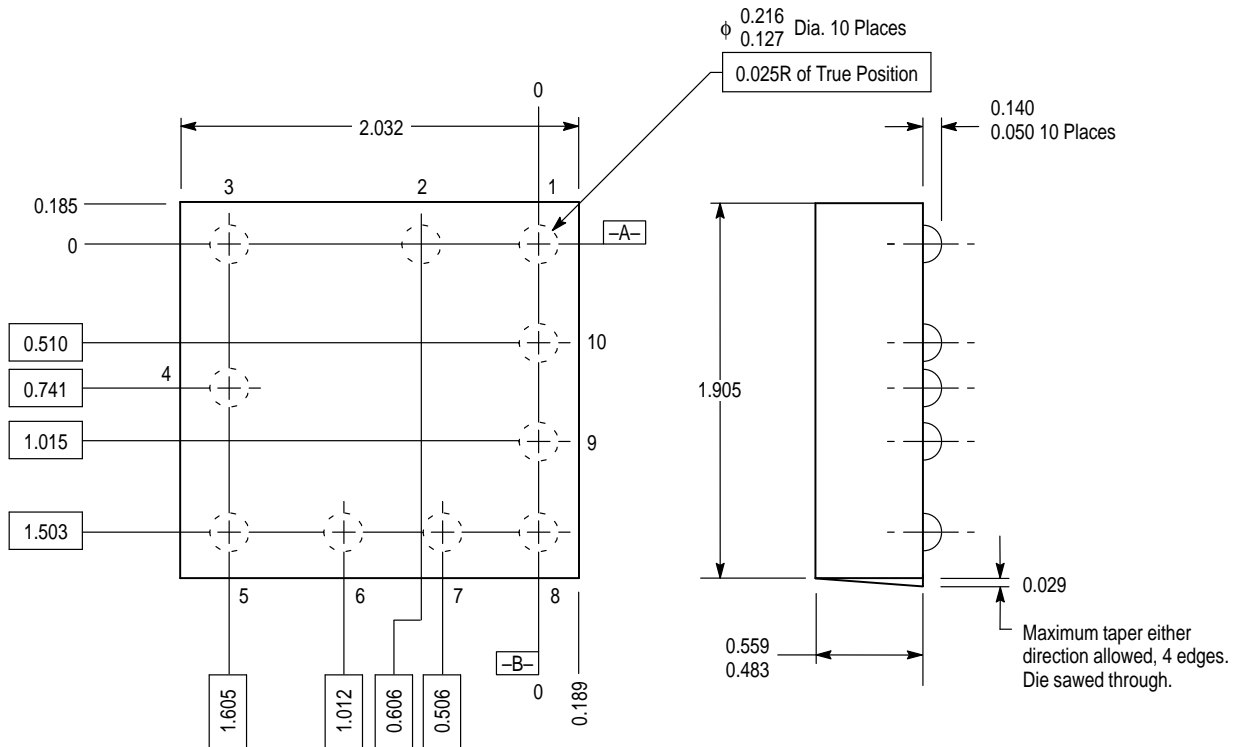

- NOTES:**
- All dimensions shown indicated in millimeters.
  -  Denotes basic dimension having zero tolerance and describes the theoretical exact location (true position) or contour.

Figure 2. Pins 1, 3 and 4 Field Transient Decay

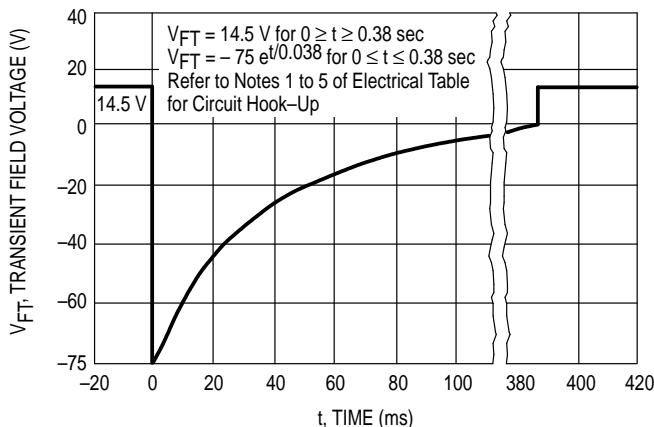

Figure 3. Pins 1 and 4 Load Dump Transient Decay

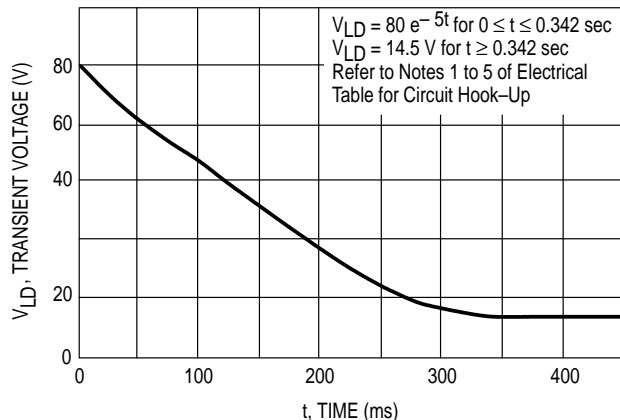

Figure 4. Temperature versus  $V_{bat}$  for 50% Duty Cycle

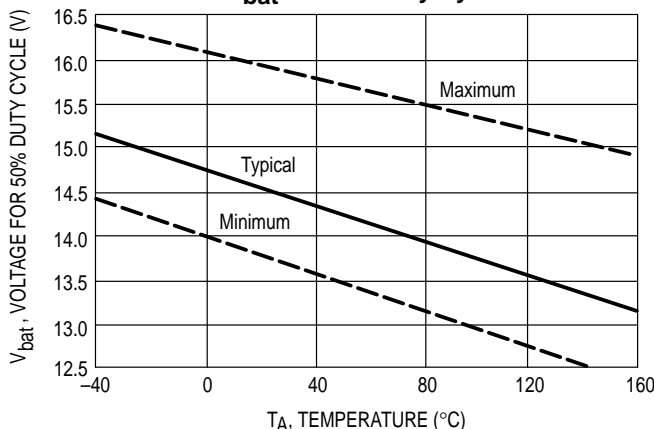

Figure 5.  $V_{bat}$  (50% Duty Cycle) versus  $V_{bat}$  (Lamp "On")

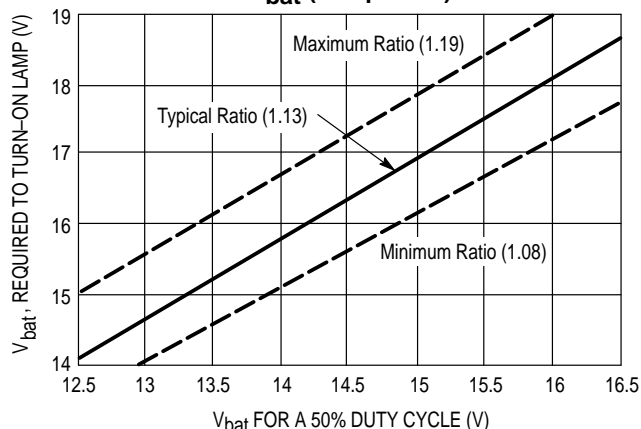

Figure 6. Field Current versus Cycle Time

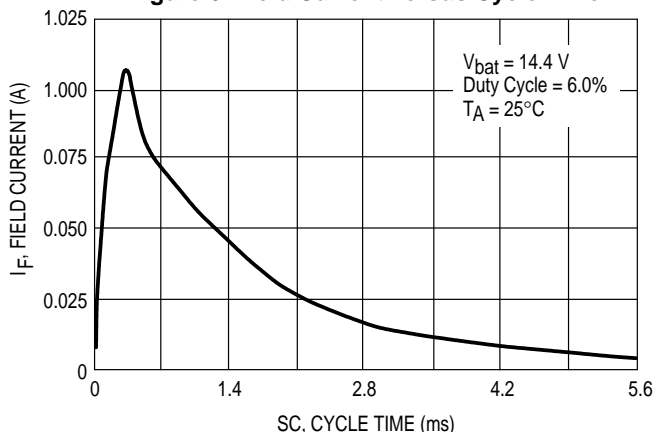
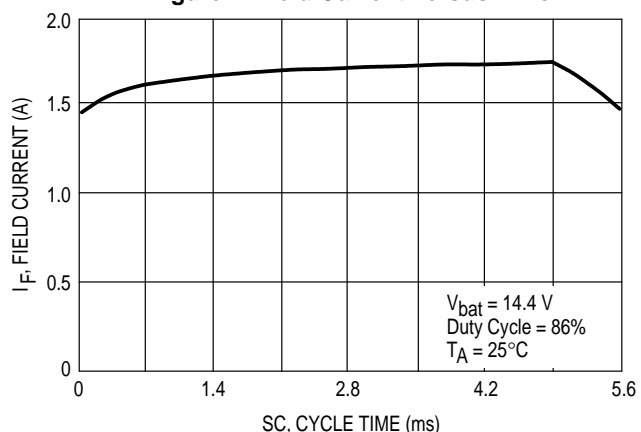
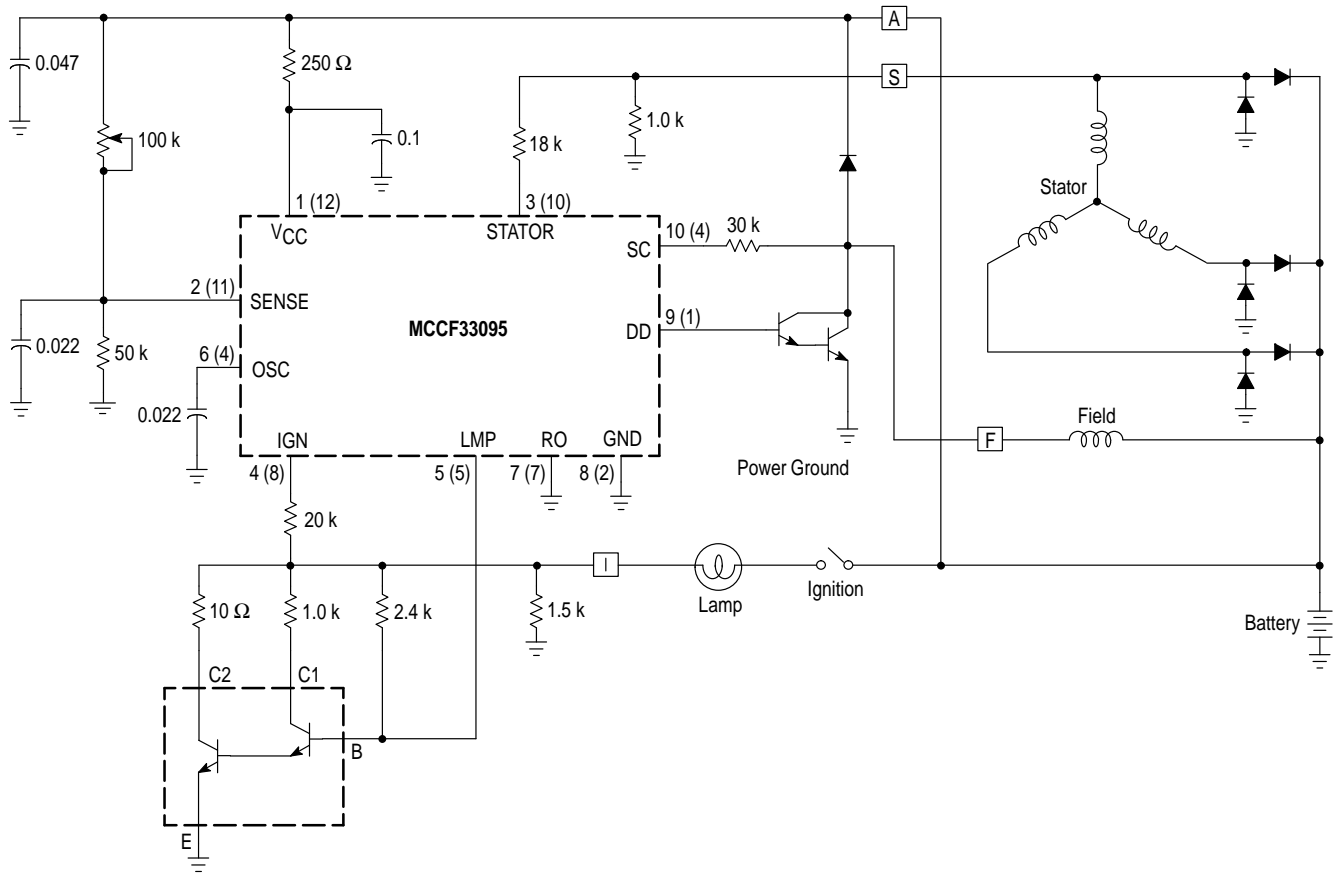

Figure 7. Field Current versus Time



# MCCF33095 MC33095

Figure 8. Integral Alternator Regulator System



# MCCF33095 MC33095

## FUNCTIONAL DESCRIPTION

### Introduction

This ignition control circuit was originally designed and offered as an MCCF33095 Flip–Chip for use in 12 V automotive alternator charging systems. The MCCF33095 consists of many protection features which are entailed in a ten pin flip–chip package. The device was subsequently made available in a 14 pin surface mount version (MC33095D). Both versions perform in a similar manner. The Flip–Chip version has an advantage over the surface mount version where minimized space and higher operating ambient temperatures are of major concern. Device operation and application suggestions for both versions are given below.

### Oscillator

The oscillator frequency is determined by the value of an external capacitor from the Oscillator pin to ground (see applications circuit). The oscillator frequency in a typical application is approximately 175 Hz, but a range of 50 Hz to 500 Hz can reasonably be used. The waveform generated consists of a positive linear slope followed by relatively fast negative fall (sawtooth). The flip–flops are reset by the falling edge of the sawtooth signal as shown on the logic diagram. The oscillator signal peaks at approximately 3.0 V and provides the timing required for the device.

### Ignition

The Ignition input signal enables the device turn–on when the Ignition pin voltage is greater than 1.4 V. This signal normally originates from the ignition switch of automotive systems.

### Sense

The Sense pin functions as a voltage sensor. It proportionally senses the battery voltage and determines the amount of time the Darlington transistor is high over the next cycle. A low voltage at the Sense pin will result in a long duty cycle for the Darlington while a high voltage produces a short duty cycle. In the application, proportional control is used to determine the duty cycle. Proportional control is defined as the sense ratio of battery voltage, present on the Sense pin, required to obtain a 20% to 95% duty cycle range in the application. The 20% duty cycle value will correlate to the maximum battery in the application. Normally the sense ratio of battery voltage is an end product trim adjustment.

### Lamp

The Lamp output pin functions as a warning indicator for overvoltage and stopped engine or broken belt conditions existing in the system.

### Stator

The Stator pin senses the voltage from the stator in the application circuit, and keeps the device powered up while the stator voltage is high. Furthermore, it acts as a sense for a stopped engine or broken belt condition. If this condition is detected, the Stator turns “on” the Lamp.

### Power Supply, V<sub>CC</sub>

The V<sub>CC</sub> pin powers the entire device and disables all outputs during any overvoltage condition.

### Roll–Off

The Roll–Off pin provides thermal protection for the circuit. This capability exists, but has not been characterized and is not tested for at this time. Therefore, it is recommended that this pin be connected to ground. The surface mount version has this pin internally connected to ground.

### Darlington Drive

The purpose of the Darlington Drive output pin is to turn on an external power Darlington transistor. The Sense pin voltage determines the duty cycle of the Darlington. The oscillator is set to maintain a minimum duty cycle, except during overvoltage and short circuit conditions.

### Short Circuit

The Short Circuit pin monitors the field voltage. When the Darlington Drive and Short Circuit pins are simultaneously high for a duration greater than the slew rate period, a short circuit condition is noted. The detection time required prevents the device from reacting to false shorts. As a result of short circuit detection, the output is disabled. During a short circuit condition, the device automatically retries with a 2% duty cycle (Darlington “on” time). Once the short circuit condition ceases, normal device operation resumes.

### Application Notes

A capacitor should be used in parallel with the V<sub>CC</sub> pin to filter out noise transients on the supply or battery line. Likewise, a capacitor should be used in parallel with the Sense pin to create a dominant closed loop pole. Resistors connected to inputs, as mentioned in Notes 1 through 5 of the Electrical Characteristic table, should be used.

## FLIP-CHIP APPLICATION INFORMATION

**Introduction**

Although the packaging technology known as “flip-chip” has been available for some time, it has seen few applications outside the automotive and computer industries. Present microelectronic trends are demanding smaller chip sizes, reduced manufacturing costs, and improved reliability. Flip-chip technology satisfies all of these needs.

Conventional assembly techniques involve bonding wires to metal pads to make electrical contact to the integrated circuit. Flip-chip assembly requires further processing of the integrated circuit after final nitride deposition to establish robust solder bumps with which to make electrical contact to the circuit. A spatially identical solderable solder bump pattern, normally formed on ceramic material, serves as a substrate host for the flip-chip. The “bumped” flip-chip is aligned to, and temporarily held in place through the use of soldering paste. The aligned flip-chip and substrate host are placed into an oven and the solder reflowed to establish both electrical and mechanical bonding of the flip-chip to the substrate circuit. Use of solder paste not only holds the chip in temporary placement for reflow but also enhances the reflow process to produce highly reliable bonds.

**Flip-Chip Benefits**

Some of the benefits of flip-chip assembly are:

- 1) Higher circuit density resulting in approximately one-tenth the footprint required of a conventional plastic encapsulated device.
- 2) Improved reliability, especially in high temperature applications. This is due, in part, to the absence of wires to corrode or fatigue from extensive thermal cycling.
- 3) No bond wires are required that might possibly become damaged during assembly.
- 4) Adaptable for simultaneous assembly of multiple flip-chips, in a hybrid fashion, onto a single ceramic substrate.

The following discussion covers the flip-chip process steps performed by Motorola, and the assembly processing required by the customer, in order to attach the flip-chip onto a ceramic substrate.

**MOTOROLA'S FLIP-CHIP PROCESS****Overview**

The process steps to develop an integrated circuit flip-chip are identical to that of conventional integrated circuits up to and including the deposition of the final nitride passivation layer on the front surface (circuit side). At this stage all device metal interconnects are present.

The process sequence is as follows:

- 1) Passivation-nitride photoresist and etch
- 2) Bimetal sputter (titanium (Ti) and tungsten (W) followed by copper (Cu))
- 3) Photo mask to define the bump area
- 4) Copper plate
- 5) Lead plate
- 6) Tin plate
- 7) Photoresist clean to remove all photoresist material
- 8) Bimetal etchback
- 9) Reflow for bump formation
- 10) Final inspection

The diagram below depicts the various layers involved in the bump process.

**Figure 9. Plated Bump Structure and Process Flow**

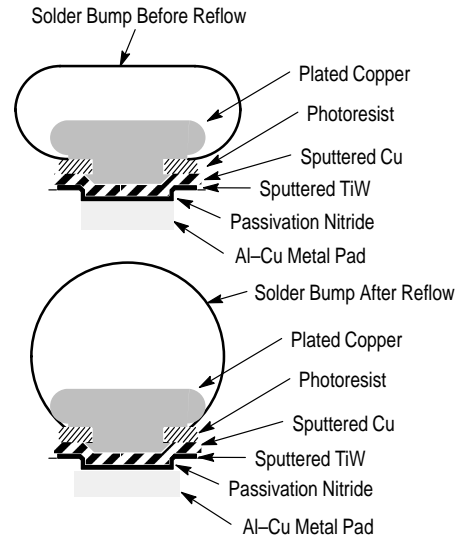

Initially, photoresist techniques are used to create openings in the nitride passivation layer exposing the metal pad bias. Ti/W, followed by Cu, are sputtered across the entire wafer surface. The surface is then photo patterned to define the bump areas. The sputtered metals together constitute a base metal for the next two metal depositions.

The Ti/W layer provides excellent intermetallic adhesion between the metal pads and the sputtered copper. In addition, the Ti/W provides a highly reliable interface to absorb mechanical shock and vibrations frequently encountered in automotive applications. The sputtered copper layer creates a platform onto which an electroplated copper layer can be built-up. Layers of Cu, Pb, and Sn are applied by plating onto the void areas of the photoresist material. The photoresist is then removed and the earlier sputtered materials are etched away. The flip-chip wafer is then put into an oven exposing it to a specific ambient temperature which causes the lead and tin to ball-up and form a solder alloy.

**IC Solder Bumps**

The solder consists of approximately 93% lead and 7% tin. The alloying of lead with tin provides a bump with good ductility and joint adhesion properties. Precise amounts of tin are used in conjunction with lead. Too much tin in relation to lead can cause the solder joints to become brittle and subject to fatigue failure. Motorola has established what it believes to be the optimum material composition necessary in order to achieve high bump reliability.

In the make-up of the flip-chip design, bumps are ideally spaced evenly and symmetrically along each edge of the chip allowing for stress experienced during thermal expansion and vibration to be distributed evenly from bump to bump. The bump dimensions and center-to-center spacing (pitch) are specified by the chip layout and the specific application. The nominal diameter of the bumps is 6.5 mils and the minimum center-to-center pitch is roughly 8.0 mils.

## Reflow

The reflow process creates a thermally induced amalgam of the lead and tin. In the melting process, the surface tension is equalized causing the melted solder to uniformly ball up as mentioned earlier.

The ideal reflow oven profile gradually ramps up in temperature to an initial plateau. The purpose of the plateau is to establish a near equilibrium temperature just below that of the solder's melting temperature. Following the preheat, a short time and higher temperature excursion is necessary. This is to ensure adequate melting of the solder materials. The temperature is then ramped down to room temperature.

An atmosphere of hydrogen is used during the reflow heat cycle. The hydrogen provides a reducing atmosphere for the removal of any surface oxides present. The formation or presence of oxides can cause degradation in the bond reliability of the product.

During the flip-chip attachment reflow onto the ceramic substrate host, the created surface tension of the molten solder aids in the alignment of the chip onto the ceramic substrate.

## Reliability

Motorola is determined to bring high quality and reliable products to its customers. This is being brought about by increased automation, in-line Statistical Process Control (SPC), bump shear strength testing, thermocycling from  $-40^{\circ}$  to  $+140^{\circ}\text{C}$ , process improvements such as backside laser marking of the silicon chip, and improved copper plating techniques.

## ATTACHING FLIP-CHIPS ONTO CERAMIC SUBSTRATES

### Overview

The assembly or process of attaching the flip-chip onto a ceramic substrate is performed by the module fabricator. Prior to actual assembly, the ceramic substrate should undergo several process steps. Care should be exercised to properly orient the flip-chip onto the substrate host in order to accommodate the appropriate solder bumps. Ideally, the flip-chip should be removed from the wafer pack with a pick and place machine utilizing a vacuum pick-up to move the die onto the ceramic substrate. Any other components to be reflow soldered onto the substrate can be placed onto the substrate in a similar manner. Flip-chip assembly onto a ceramic substrate allows for some passive components, such as resistors, to be formed directly into the ceramic substrate circuit pattern itself. With all surface components to be mounted in place on the ceramic substrate, the assembly is moved into the furnace where it undergoes a specified temperature variation to solder all the components onto the ceramic substrate. This is accomplished by melting (reflowing) the substrate solder bumps. The resulting assembly should, after being cooled, be cleaned to remove any flux residues. If the substrate assembly is to be mounted into a module, it is recommended that the cavity of the module be filled with an appropriate silicon gel. The use of a gel coating helps to seal the individual components on the

substrate from external moisture. A commonly used gel for this purpose is Dow Corning 562. As a final module assembly step, a cover is recommended to be placed over the ceramic assembly for further protection of the circuit.

It should be pointed out that the commonly used ceramic substrate material, though more expensive than other substrate materials, offers significantly superior thermal properties. By comparison, the use of ceramic material offers 33 times the thermal advantage of the second best material, Ceracom. The common FR-4 epoxy material is 100 times less thermally conductive than ceramic. For applications where dielectric constants are important and/or heat dissipation is not of real importance, other less costly materials can be used. The basic concept of the process is identical for all flip-chip substrates used.

Figure 10. Process Flow Diagram

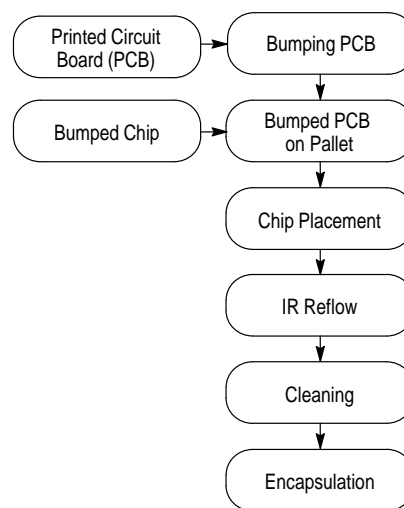

### Ceramic Substrate Preparation

The recommended ceramic substrate is aluminum oxide. These substrates come connected in what is referred to as a card. This is identical to the concept of die or chips on a wafer. Each card usually contains 8 to 16 substrates.

Initially, the ceramic should be precleaned with isopropyl alcohol, followed by freon. The bump pattern is then transferred onto the substrate using a metal stencil technique using a palladium silver conducting paste, such as DuPont 9476, through a #325 mesh. Once the pattern is applied, the substrate is dried for ten minutes at  $150^{\circ}\text{C}$  and then fired for 60 minutes at a temperature increasing to a peak of  $850^{\circ}\text{C}$  for ten additional minutes. Solder paste is then stenciled onto the pads.

A metal etched stencil defining the contact areas is recommended. The use of an etched stencil affords better solder paste control than does a silk screen. The metal stencil affords a deposition of a known amount of solder paste, thereby preventing bridging caused by excess solder usage.



**Solder Paste Content**

It is recommended that the solder paste consist of 10% tin, 88% lead, and 2% silver alloy. However, 95/3/2 compositions have had successful results.

A rosin based flux, such as RMA (Rosin Mildly Activated) manufactured by Dupont and having spherical particles of 45 to 75 microns, should be used. The tackiness of the solder paste at room temperature helps to hold the flip-chip in place during the pick and place operation. The use of flux:

- 1) Prevents excess oxidation during reflow.
- 2) Optimizes the flow of liquid solder through the stencil.
- 3) Smooths the surface by reducing surface tension, and
- 4) Enhances the normalization of surface tension upon reflow causing the flip-chip bumps to effectively auto-align themselves to substrate bump pads.

A solder mask can be used for applications requiring high precision as shown in Figures 11a and 11b.

**Figure 11a. Before Reflow**

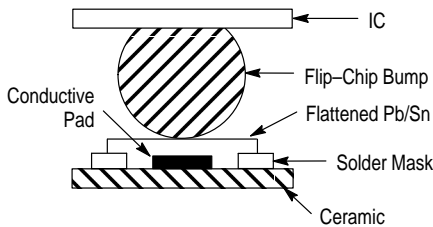

**Figure 11b. After Reflow**

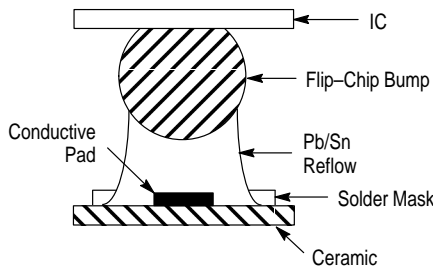

**Oven Profile**

After the flip-chip is placed onto the bumped substrate, the substrate and flip-chip are ready for reflow. Initially, the flip-chip is heated to a peak temperature of around 300° to 350°C for five minutes. It is to be noted that the flip-chip bumps have a higher melting temperature than the bumps on the substrate. During assembly reflow, the substrate bumps melt and create a substrate to flip-chip bump bond. After reflow, the assembled part is cooled to room temperature or

to some intermediate temperature point for annealing purposes.

**Figure 12. Reflow Oven Profile**

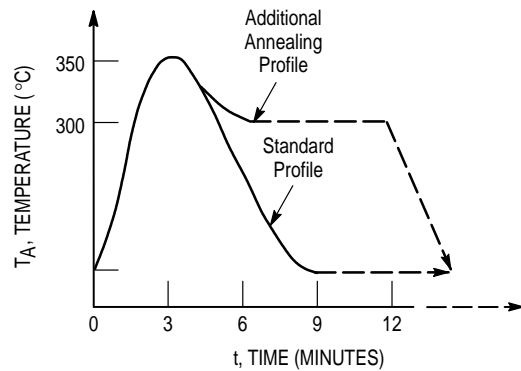

The oven temperature profile is established primarily to melt the solder while minimizing the alloying of the materials and keeping the flux from boiling away. It should be noted that when the flip-chip is placed onto the substrate, the material is stressed in one direction or another. The use of flux helps to reduce any surface stresses present. A reduction in the surface stress enhances solder wetting which in turn aids in the alignment of the flip-chip to the substrate. Poor solder wetting will produce misalignment as well as inferior bond strengths and reliability.

It is recommended that an inert atmosphere such as nitrogen be used during the reflow process to prevent oxidation.

**Final Cleaning**

The final cleaning involves removing the remaining flux from the flip-chip assembly. Three possible methods of removing flux are: ultrasonic cleaner, Terpene solvent and DI water, or vapor degreaser. The flux manufacturer should be able to recommend the proper type of vapor degreaser to be used.

**Test and Reliability**

Both visual inspection and shear strength testing should be performed on packaged flip-chip assemblies.

Solder reflow results that exhibit a grainy and dull appearance produce inferior bond shear strengths. Inferior bond shear strengths are visually recognizable by:

- 1) The presence of old or badly oxidized solder paste.
- 2) Insufficient amount of solderable material.
- 3) The contamination of bond pads with grease, oil, etc.

It should be mentioned that many contaminants are transparent and not easily detectable by visual means.

Shear strength testing should meet a 0.8 Newtons/Bump criteria. Shear strength testing should follow thermocycling of the chip from  $-40^{\circ}$  to  $+140^{\circ}\text{C}$  to insure the stability of shear strength over temperature. Figure 13 depicts a test set-up which might possibly be used.

**Figure 13. Shear Test Fixture**

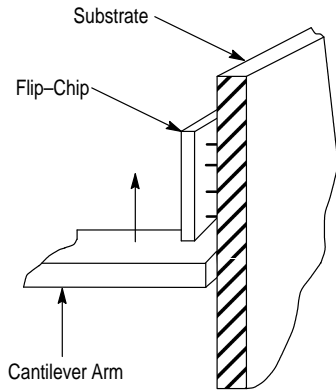

Aside from physical contamination, flip-chips, like any other chips, should not be handled directly due to the fact that electrostatic discharges can cause permanent damage to the electronic circuit. Flip-chips which do survive an electrostatic discharge can be left in a weakened condition resulting in reduced reliability of the end product. To avoid electrostatic damage of the circuit, assembly personnel should make use of a wrist strap or some other device to provide electrostatic grounding of their body. For the same reason, machinery used to assemble semiconductor circuits should be electrostatically grounded.

Flip-chips rely primarily on the thermal path established by the bumps to remove heat from the chip as a result of internal circuit operation. Standard Motorola flip-chips have a thermal resistance of approximately  $290^{\circ}\text{C/W/Bump}$ . This figure can be used to estimate the allowed maximum power dissipation of the chip.

#### **Cost and Equipment Manufacturers**

The cost of implementing a flip-chip assembly process depends on the specific production requirements and as a result will vary over a broad range. It is possible to implement a small volume laboratory set-up for a few hundred dollars using manual operations. At the other end of the scale one could spend millions setting up a fully automated line incorporating pattern recognition, chip and substrate

orientation, reflow, cleaning, and test. The module fabricator will have to make this assessment.

An assembly operator can manually accomplish the pick and place operation using a vacuum probe to pick-up and orient the flip-chip onto the substrate. Furthermore, it is possible to perform the reflow assembly operation using a simple batch process oven fabricated from a laboratory hot plate. However, the use of such process techniques will have questionable impact on the final product's reliability and quality. For this reason, it is highly recommended that the module fabricator seriously consider two major pieces of equipment; a pick and place machine and an infrared solder reflow oven. Both pieces of equipment can vary over a wide cost range depending on the production requirements. A partial list of manufacturers for this equipment is given below.

#### **Pick and Place Machine:**

Universal Instruments Corp.  
Dover Technologies, Inc.  
Binghamton, NY 13902  
(607) 772-7522

Seiko  
Torrance, CA 90505  
(310) 517-7850

Laurier Inc.  
Hudson, NH 03051  
(603) 889-8800

#### **Infrared Reflow Oven:**

BTU  
Bellerica, MA 01862  
(508) 667-4111

Vitronics  
Newmarket, NH 03857  
(603) 659-6550

#### **Additional Applications**

Completed ceramic flip-chip sub-assemblies can be stacked one on top of another to produce an overall assembly by making contact connections through bumps. This technology is beginning to emerge in the computer industry where physical module size is of significant importance. Furthermore, this assembly technology, though more complex, is undergoing serious consideration within the automotive industry as well.

Applications requiring small size and high reliability at high ambient temperatures can benefit considerably through the implementation of flip-chip assembly techniques.

OUTLINE DIMENSIONS

**D SUFFIX**  
 PLASTIC PACKAGE  
 CASE 751A-03  
 (SO-14)  
 ISSUE F

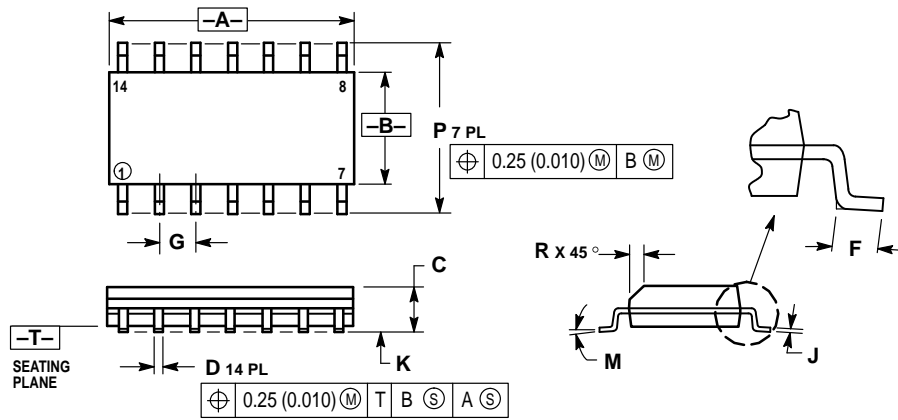

- NOTES:
1. DIMENSIONING AND TOLERANCING PER ANSI Y14.5M, 1982.
  2. CONTROLLING DIMENSION: MILLIMETER.
  3. DIMENSIONS A AND B DO NOT INCLUDE MOLD PROTRUSION.
  4. MAXIMUM MOLD PROTRUSION 0.15 (0.006) PER SIDE.
  5. DIMENSION D DOES NOT INCLUDE DAMBAR PROTRUSION. ALLOWABLE DAMBAR PROTRUSION SHALL BE 0.127 (0.005) TOTAL IN EXCESS OF THE D DIMENSION AT MAXIMUM MATERIAL CONDITION.

DIM	MILLIMETERS		INCHES	
	MIN	MAX	MIN	MAX
A	8.55	8.75	0.337	0.344
B	3.80	4.00	0.150	0.157
C	1.35	1.75	0.054	0.068
D	0.35	0.49	0.014	0.019
F	0.40	1.25	0.016	0.049
G	1.27 BSC		0.050 BSC	
J	0.19	0.25	0.008	0.009
K	0.10	0.25	0.004	0.009
M	0° 7°		0° 7°	
P	5.80	6.20	0.228	0.244
R	0.25	0.50	0.010	0.019

Motorola reserves the right to make changes without further notice to any products herein. Motorola makes no warranty, representation or guarantee regarding the suitability of its products for any particular purpose, nor does Motorola assume any liability arising out of the application or use of any product or circuit, and specifically disclaims any and all liability, including without limitation consequential or incidental damages. "Typical" parameters which may be provided in Motorola data sheets and/or specifications can and do vary in different applications and actual performance may vary over time. All operating parameters, including "Typicals" must be validated for each customer application by customer's technical experts. Motorola does not convey any license under its patent rights nor the rights of others. Motorola products are not designed, intended, or authorized for use as components in systems intended for surgical implant into the body, or other applications intended to support or sustain life, or for any other application in which the failure of the Motorola product could create a situation where personal injury or death may occur. Should Buyer purchase or use Motorola products for any such unintended or unauthorized application, Buyer shall indemnify and hold Motorola and its officers, employees, subsidiaries, affiliates, and distributors harmless against all claims, costs, damages, and expenses, and reasonable attorney fees arising out of, directly or indirectly, any claim of personal injury or death associated with such unintended or unauthorized use, even if such claim alleges that Motorola was negligent regarding the design or manufacture of the part. Motorola and  registered trademarks of Motorola, Inc. Motorola, Inc. is an Equal Opportunity/Affirmative Action Employer.

**How to reach us:**

**USA/EUROPE/Locations Not Listed:** Motorola Literature Distribution;  
P.O. Box 20912; Phoenix, Arizona 85036. 1-800-441-2447 or 602-303-5454

**JAPAN:** Nippon Motorola Ltd.; Tatsumi-SPD-JLDC, 6F Seibu-Butsuryu-Center,  
3-14-2 Tatsumi Koto-Ku, Tokyo 135, Japan. 03-81-3521-8315

**ASIA/PACIFIC:** Motorola Semiconductors H.K. Ltd.; 8B Tai Ping Industrial Park,  
51 Ting Kok Road, Tai Po, N.T., Hong Kong. 852-26629298

