

**MCM67M618A**

*Product Preview*

**64K x 18 Bit BurstRAM**  
**Synchronous Fast Static RAM**  
**With Burst Counter and Self-Timed Write**

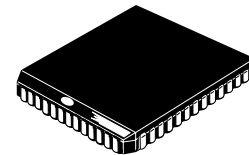

**FN PACKAGE**  
**PLASTIC**  
**CASE 778-02**

The MCM67M618A is a 1,179,648 bit synchronous static random access memory designed to provide a burstable, high-performance, secondary cache for the MC68040 and PowerPC™ microprocessors. It is organized as 65,536 words of 18 bits, fabricated using Motorola's high-performance silicon-gate BiCMOS technology. The device integrates input registers, a 2-bit counter, high speed SRAM, and high drive capability outputs onto a single monolithic circuit for reduced parts count implementation of cache data RAM applications. Synchronous design allows precise cycle control with the use of an external clock (K). BiCMOS circuitry reduces the overall power consumption of the integrated functions for greater reliability.

Addresses (A0 – A15), data inputs (DQ0 – DQ17), and all control signals, except output enable ( $\bar{G}$ ), are clock (K) controlled through positive-edge-triggered noninverting registers.

Bursts can be initiated with either transfer start processor ( $\bar{TSP}$ ) or transfer start cache controller ( $\bar{TSC}$ ) input pins. Subsequent burst addresses are generated internally by the MCM67M618A (burst sequence imitates that of the MC68040) and controlled by the burst address advance ( $\bar{BAA}$ ) input pin. The following pages provide more detailed information on burst controls.

Write cycles are internally self-timed and are initiated by the rising edge of the clock (K) input. This feature eliminates complex off-chip write pulse generation and provides increased flexibility for incoming signals.

Dual write enables ( $\bar{LW}$  and  $\bar{UW}$ ) are provided to allow individually writeable bytes.  $\bar{LW}$  controls DQ0 – DQ8 (the lower bits), while  $\bar{UW}$  controls DQ9 – DQ17 (the upper bits).

This device is ideally suited for systems that require wide data bus widths and cache memory.

- Single 5 V ± 5% Power Supply
- Fast Access Times: 9/10/12 ns Max
- Byte Writeable via Dual Write Strokes
- Internal Input Registers (Address, Data, Control)
- Internally Self-Timed Write Cycle
- $\bar{TSP}$ ,  $\bar{TSC}$ , and  $\bar{BAA}$  Burst Control Pins
- Asynchronous Output Enable Controlled Three-State Outputs
- Common Data Inputs and Data Outputs
- High Board Density 52-PLCC Package
- 3.3 V I/O Compatible

**PIN ASSIGNMENT**

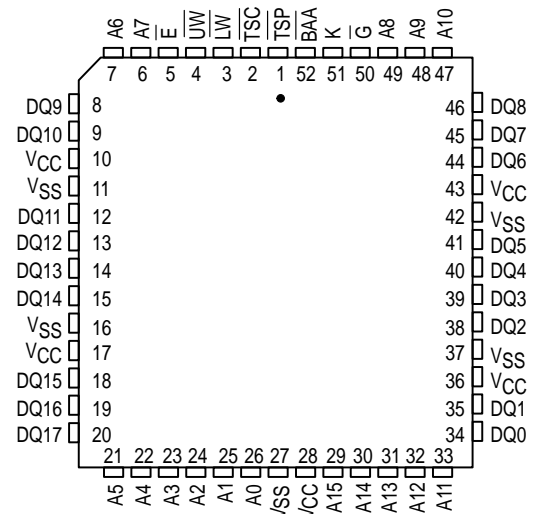

**PIN NAMES**

A0 – A15	Address Inputs
K	Clock
$\bar{BAA}$	Burst Address Advance
$\bar{LW}$	Lower Byte Write Enable
$\bar{UW}$	Upper Byte Write Enable
$\bar{TSP}$ , $\bar{TSC}$	Transfer Start
$\bar{E}$	Chip Enable
$\bar{G}$	Output Enable
DQ0 – DQ17	Data Input/Output
VCC	+ 5 V Power Supply
VSS	Ground

All power supply and ground pins must be connected for proper operation of the device.

PowerPC is a trademark of IBM Corp.

This document contains information on a new product under development. Motorola reserves the right to change or discontinue this product without notice.

REV 1  
5/95

## BLOCK DIAGRAM (See Note)

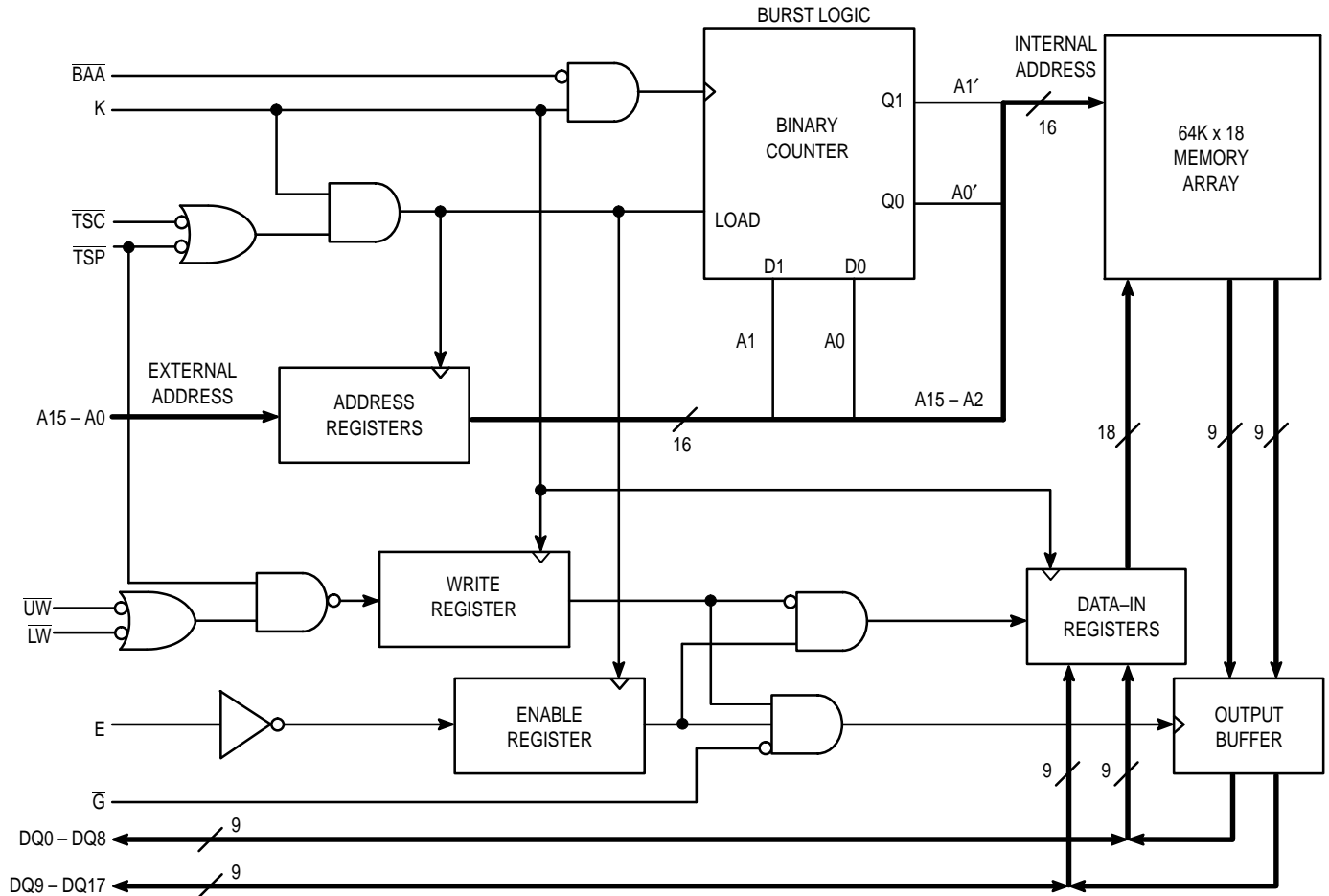

NOTE: All registers are positive-edge triggered. The  $\overline{TSC}$  or  $\overline{TSP}$  signals control the duration of the burst and the start of the next burst. When  $\overline{TSP}$  is sampled low, any ongoing burst is interrupted and a read (independent of  $\overline{W}$  and  $\overline{TSC}$ ) is performed using the new external address. Alternatively, a  $\overline{TSP}$ -initiated two cycle WRITE can be performed by asserting  $\overline{TSP}$  and a valid address on the first cycle, then negating both  $\overline{TSP}$  and  $\overline{TSC}$  and asserting  $\overline{LW}$  and/or  $\overline{UW}$  with valid data on the second cycle (see Single Write Cycle in WRITE CYCLES timing diagram).

When  $\overline{TSC}$  is sampled low (and  $\overline{TSP}$  is sampled high), any ongoing burst is interrupted and a read or write (dependent on  $\overline{W}$ ) is performed using the new external address. Chip enable ( $\overline{E}$ ) is sampled only when a new base address is loaded. After the first cycle of the burst,  $\overline{BAA}$  controls subsequent burst cycles. When  $\overline{BAA}$  is sampled low, the internal address is advanced prior to the operation. When  $\overline{BAA}$  is sampled high, the internal address is not advanced, thus inserting a wait state into the burst sequence accesses. Upon completion of a burst, the address will wrap around to its initial state. See **BURST SEQUENCE TABLE**. Write refers to either or both byte write enables ( $\overline{LW}$ ,  $\overline{UW}$ ).

## BURST SEQUENCE GRAPH (See Note)

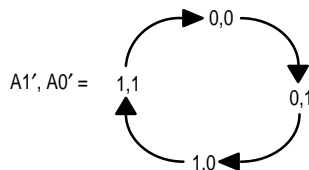

NOTE: The external two values for A1 and A0 provide the starting point for the burst sequence graph. The burst logic advances A1 and A0 as shown above.

## SYNCHRONOUS TRUTH TABLE (See Notes 1, 2, and 3)

$\bar{E}$	TSP	TSC	BAA	LW or UW	K	Address	Operation
H	L	X	X	X	L-H	N/A	Deselected
H	X	L	X	X	L-H	N/A	Deselected
L	L	X	X	X	L-H	External Address	Read Cycle, Begin Burst
L	H	L	X	L	L-H	External Address	Write Cycle, Begin Burst
L	H	L	X	H	L-H	External Address	Read Cycle, Begin Burst
X	H	H	L	L	L-H	Next Address	Write Cycle, Continue Burst
X	H	H	L	H	L-H	Next Address	Read Cycle, Continue Burst
X	H	H	H	L	L-H	Current Address	Write Cycle, Suspend Burst
X	H	H	H	H	L-H	Current Address	Read Cycle, Suspend Burst

### NOTES:

1. X means Don't Care.
2. All inputs except  $\bar{G}$  must meet setup and hold times for the low-to-high transition of clock (K).
3. Wait states are inserted by suspending burst.

## ASYNCHRONOUS TRUTH TABLE (See Notes 1 and 2)

Operation	$\bar{G}$	I/O Status
Read	L	Data Out
Read	H	High-Z
Write	X	High-Z — Data In
Deselected	X	High-Z

### NOTES:

1. X means Don't Care.
2. For a write operation following a read operation,  $\bar{G}$  must be high before the input data required setup time and held high through the input data hold time.

## ABSOLUTE MAXIMUM RATINGS (Voltages Referenced to $V_{SS} = 0$ V)

Rating	Symbol	Value	Unit
Power Supply Voltage	$V_{CC}$	- 0.5 to + 7.0	V
Voltage Relative to $V_{SS}$ for Any Pin Except $V_{CC}$	$V_{in}, V_{out}$	- 0.5 to $V_{CC} + 0.5$	V
Output Current (per I/O)	$I_{out}$	$\pm 30$	mA
Power Dissipation	$P_D$	1.6	W
Temperature Under Bias	$T_{bias}$	- 10 to + 85	°C
Operating Temperature	$T_A$	0 to +70	°C
Storage Temperature	$T_{stg}$	- 55 to + 125	°C

NOTE: Permanent device damage may occur if ABSOLUTE MAXIMUM RATINGS are exceeded. Functional operation should be restricted to RECOMMENDED OPERATING CONDITIONS. Exposure to higher than recommended voltages for extended periods of time could affect device reliability.

This device contains circuitry to protect the inputs against damage due to high static voltages or electric fields; however, it is advised that normal precautions be taken to avoid application of any voltage higher than maximum rated voltages to this high-impedance circuit.

This BiCMOS memory circuit has been designed to meet the dc and ac specifications shown in the tables, after thermal equilibrium has been established.

This device contains circuitry that will ensure the output devices are in High-Z at power up.

## DC OPERATING CONDITIONS AND CHARACTERISTICS

( $V_{CC} = 5.0\text{ V} \pm 5\%$ ,  $T_A = 0\text{ to } +70^\circ\text{C}$ , Unless Otherwise Noted)

### RECOMMENDED OPERATING CONDITIONS (Voltages referenced to $V_{SS} = 0\text{ V}$ )

Parameter	Symbol	Min	Max	Unit
Supply Voltage (Operating Voltage Range)	$V_{CC}$	4.75	5.25	V
Input High Voltage	$V_{IH}$	2.2	$V_{CC} + 0.3^{**}$	V
Input Low Voltage	$V_{IL}$	-0.5*	0.8	V

\*  $V_{IL}$  (min) = -0.5 V dc;  $V_{IL}$  (min) = -2.0 V ac (pulse width  $\leq 20.0\text{ ns}$ ) for  $I \leq 20.0\text{ mA}$ .

\*\*  $V_{IH}$  (max) =  $V_{CC} + 0.3\text{ V}$  dc;  $V_{IH}$  (max) =  $V_{CC} + 2.0\text{ V}$  ac (pulse width  $\leq 20.0\text{ ns}$ ) for  $I \leq 20.0\text{ mA}$ .

### DC CHARACTERISTICS AND SUPPLY CURRENTS

Parameter	Symbol	Min	Max	Unit
Input Leakage Current (All Inputs, $V_{in} = 0\text{ to } V_{CC}$ )	$I_{lkg(I)}$	—	$\pm 1.0$	$\mu\text{A}$
Output Leakage Current ( $\bar{G} = V_{IH}$ )	$I_{lkg(O)}$	—	$\pm 1.0$	$\mu\text{A}$
AC Supply Current ( $\bar{G} = V_{IH}$ , $\bar{E} = V_{IL}$ , $I_{out} = 0\text{ mA}$ , All Inputs = $V_{IL}$ or $V_{IH}$ , $V_{IL} = 0.0\text{ V}$ and $V_{IH} \geq 3.0\text{ V}$ , Cycle Time $\geq t_{KHKH}$ min)	$I_{CCA9}$ $I_{CCA10}$ $I_{CCA12}$	—	275 265 250	mA
AC Standby Current ( $\bar{E} = V_{IH}$ , $I_{out} = 0\text{ mA}$ , All Inputs = $V_{IL}$ and $V_{IH}$ , $V_{IL} = 0.0\text{ V}$ and $V_{IH} \geq 3.0\text{ V}$ , Cycle Time $\geq t_{KHKH}$ min)	$I_{SB1}$	—	95	mA
Output Low Voltage ( $I_{OL} = +8.0\text{ mA}$ )	$V_{OL}$	—	0.4	V
Output High Voltage ( $I_{OH} = -4.0\text{ mA}$ )	$V_{OH}$	2.4	3.3	V

NOTE: Good decoupling of the local power supply should always be used. DC characteristics are guaranteed for all possible 68040 and PowerPC bus cycles.

### CAPACITANCE (f = 1.0 MHz, dV = 3.0 V, $T_A = 25^\circ\text{C}$ , Periodically Sampled Rather Than 100% Tested)

Parameter	Symbol	Min	Typ	Max	Unit
Input Capacitance (All Pins Except DQ0 – DQ17)	$C_{in}$	—	4	5	pF
Input/Output Capacitance (DQ0 – DQ17)	$C_{I/O}$	—	6	8	pF

## AC OPERATING CONDITIONS AND CHARACTERISTICS

( $V_{CC} = 5.0 \text{ V} \pm 5\%$ ,  $T_A = 0 \text{ to } +70^\circ\text{C}$ , Unless Otherwise Noted)

Input Timing Measurement Reference Level ..... 1.5 V  
 Input Pulse Levels ..... 0 to 3.0 V  
 Input Rise/Fall Time ..... 3 ns

Output Timing Reference Level ..... 1.5 V  
 Output Load ..... See Figure 1A Unless Otherwise Noted

### READ/WRITE CYCLE TIMING (See Notes 1, 3, and 4)

Parameter	Symbol	MCM67M618A-9		MCM67M618A-10		MCM67M618A-12		Unit	Notes
		Min	Max	Min	Max	Min	Max		
Cycle Time	$t_{KHKH}$	15	—	16.6	—	20	—	ns	
Clock Access Time	$t_{KHQV}$	—	9	—	10	—	12	ns	5
Output Enable to Output Valid	$t_{GLQV}$	—	5	—	5	—	6	ns	
Clock High to Output Active	$t_{KHQX1}$	6	—	6	—	6	—	ns	
Clock High to Output Change	$t_{KHQX2}$	3	—	3	—	3	—	ns	
Output Enable to Output Active	$t_{GLQX}$	0	—	0	—	0	—	ns	
Output Disable to Q High-Z	$t_{GHQZ}$	—	6	—	7	—	7	ns	6
Clock High to Q High-Z	$t_{KHQZ}$	3	6	3	7	3	7	ns	6
Clock High Pulse Width	$t_{KHKL}$	5	—	5	—	6	—	ns	
Clock Low Pulse Width	$t_{KLKH}$	5	—	5	—	6	—	ns	
Setup Times:									
Address	$t_{AVKH}$	2.5	—	2.5	—	2.5	—	ns	7
Address Status	$t_{TSVKH}$								
Data In	$t_{DVKH}$								
Write	$t_{WVKH}$								
Address Advance	$t_{BAVKH}$								
Chip Enable	$t_{EVKH}$								
Hold Times:									
Address	$t_{KHAX}$	0.5	—	0.5	—	0.5	—	ns	7
Address Status	$t_{KHTSX}$								
Data In	$t_{KHDX}$								
Write	$t_{KHWX}$								
Address Advance	$t_{KHBAX}$								
Chip Enable	$t_{KHEX}$								

### NOTES:

1. In setup and hold times, W (write) refers to either one or both byte write enables  $\overline{LW}$  and  $\overline{UW}$ .
2. A read cycle is defined by  $\overline{UW}$  and  $LW$  high or  $TSP$  low for the setup and hold times. A write cycle is defined by  $\overline{LW}$  or  $\overline{UW}$  low and  $\overline{TSP}$  high for the setup and hold times.
3. All read and write cycle timings are referenced from K or  $\overline{G}$ .
4.  $\overline{G}$  is a don't care when  $\overline{UW}$  or  $LW$  is sampled low.
5. Maximum access times are guaranteed for all possible MC68040 and PowerPC external bus cycles.
6. Transition is measured  $\pm 500 \text{ mV}$  from steady-state voltage with load of Figure 1B. This parameter is sampled rather than 100% tested. At any given voltage and temperature,  $t_{KHQZ} \text{ max}$  is less than  $t_{KHQZ1} \text{ min}$  for a given device and from device to device.
7. This is a synchronous device. All addresses must meet the specified setup and hold times for **ALL** rising edges of K whenever  $\overline{TSP}$  or  $\overline{TSC}$  is low, and the chip is selected. All other synchronous inputs must meet the specified setup and hold times for **ALL** rising edges of K when the chip is enabled. Chip enable must be valid at each rising edge of clock for the device (when  $\overline{TSP}$  or  $\overline{TSC}$  is low) to remain enabled.

### AC TEST LOADS

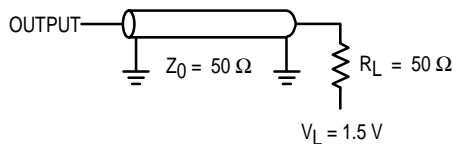

Figure 1A

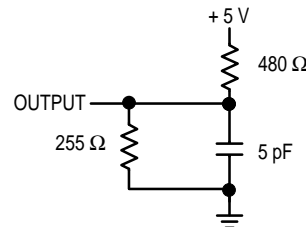
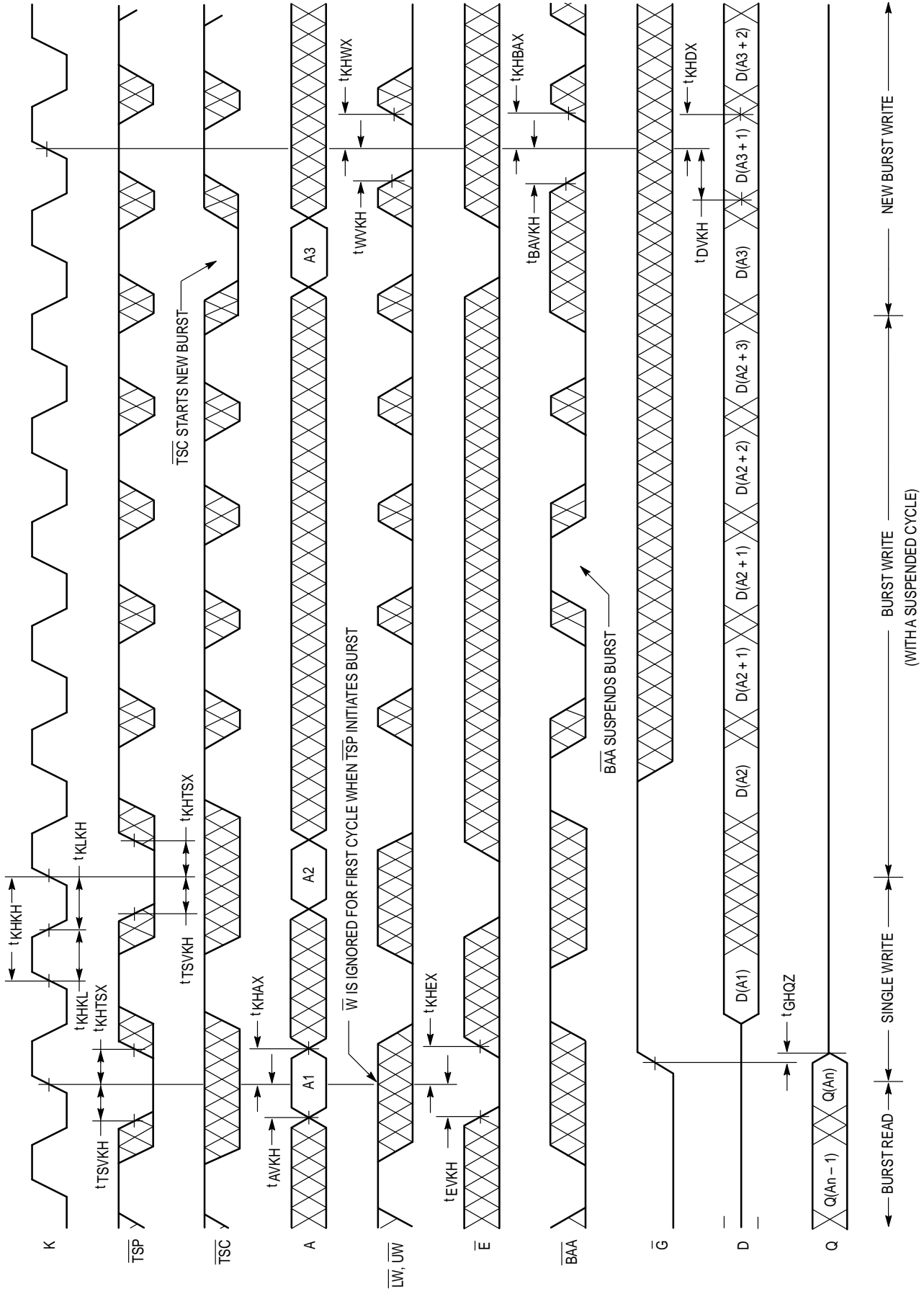

Figure 1B



WRITE CYCLES



**COMBINATION READ/WRITE CYCLE ( $\bar{E}$  low,  $\bar{TSC}$  high)**

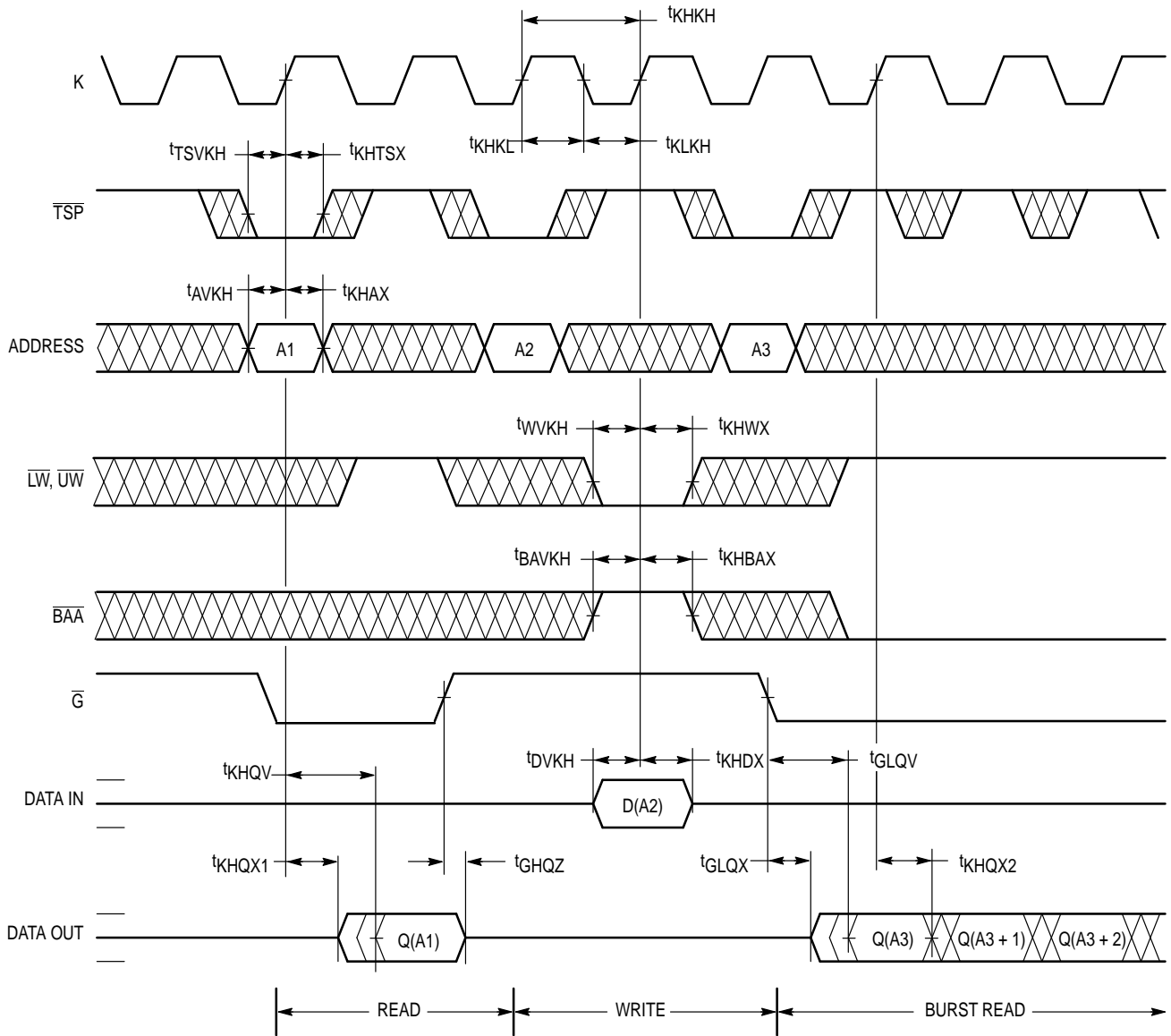



## APPLICATION EXAMPLE

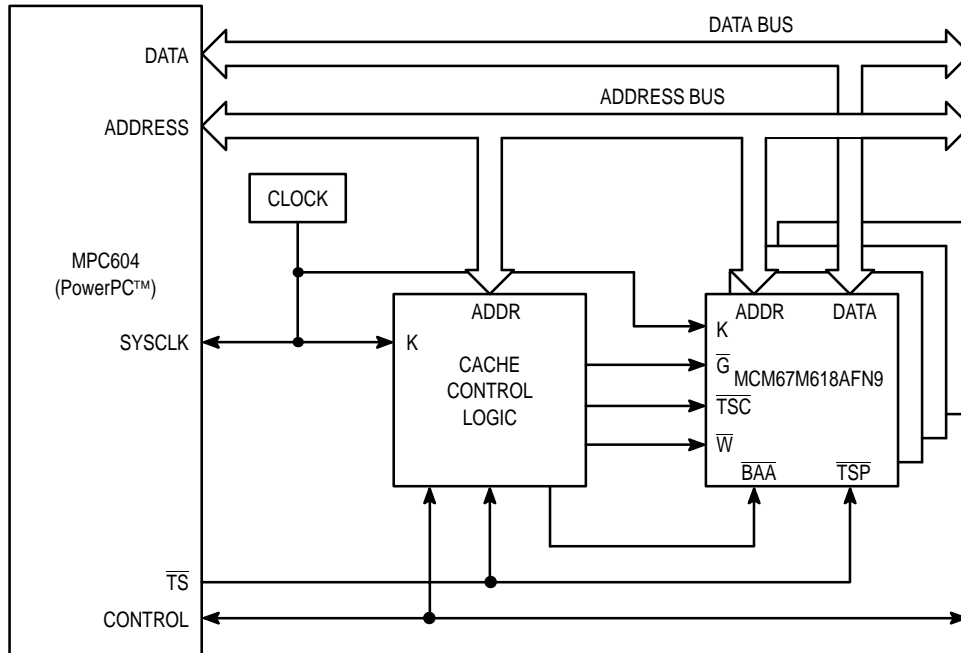

512K Byte Burstable, Secondary Cache  
Using Four MCM67M618AFN9s with a 66 MHz MPC604 PowerPC™

### ORDERING INFORMATION (Order by Full Part Number)

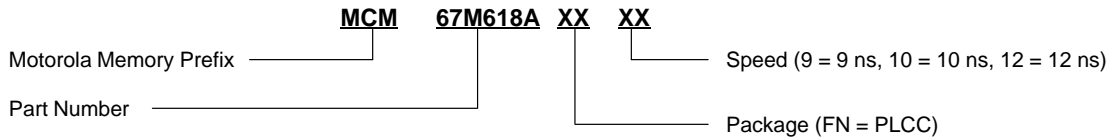

Full Part Numbers — MCM67M618AFN9 MCM67M618AFN10 MCM67M618AFN12

## PACKAGE DIMENSIONS

### FN PACKAGE 52-LEAD PLCC CASE 778-02

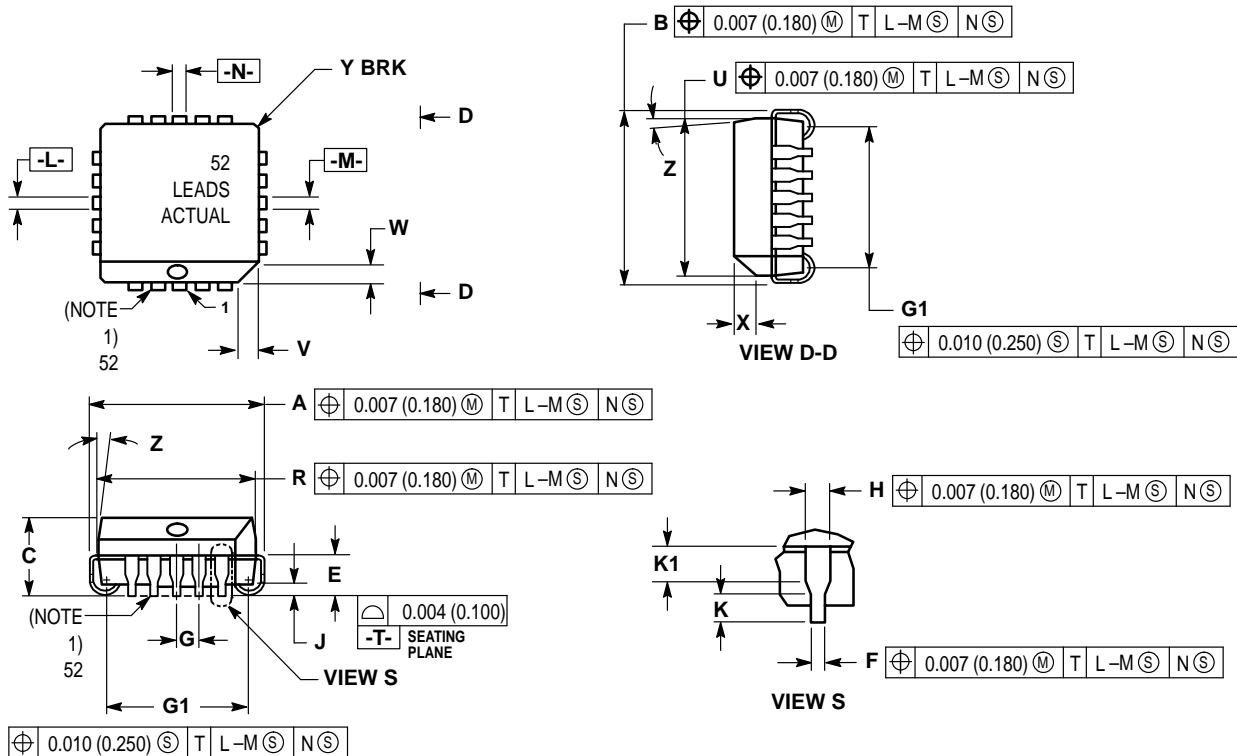

#### NOTES:

1. DUE TO SPACE LIMITATION, CASE 778-02 SHALL BE REPRESENTED BY A GENERAL (SMALLER) CASE OUTLINE DRAWING RATHER THAN SHOWING ALL 52 LEADS.
2. DATUMS -L-, -M-, AND -N- DETERMINED WHERE TOP OF LEAD SHOULDER EXITS PLASTIC BODY AT MOLD PARTING LINE.
3. DIM G1, TRUE POSITION TO BE MEASURED AT DATUM -T-, SEATING PLANE.
4. DIM R AND U DO NOT INCLUDE MOLD FLASH. ALLOWABLE MOLD FLASH IS 0.010 (0.250) PER SIDE.
5. DIMENSIONING AND TOLERANCING PER ANSI Y14.5M, 1982.
6. CONTROLLING DIMENSION: INCH.
7. THE PACKAGE TOP MAY BE SMALLER THAN THE PACKAGE BOTTOM BY UP TO 0.012 (0.300). DIMENSIONS R AND U ARE DETERMINED AT THE OUTERMOST EXTREMES OF THE PLASTIC BODY EXCLUSIVE OF MOLD FLASH, TIE BAR BURRS, GATE BURRS AND INTERLEAD FLASH, BUT INCLUDING ANY MISMATCH BETWEEN THE TOP AND BOTTOM OF THE PLASTIC BODY.
8. DIMENSION H DOES NOT INCLUDE DAMBAR PROTRUSION OR INTRUSION. THE DAMBAR PROTRUSION(S) SHALL NOT CAUSE THE H DIMENSION TO BE GREATER THAN 0.037 (0.940). THE DAMBAR INTRUSION(S) SHALL NOT CAUSE THE H DIMENSION TO BE SMALLER THAN 0.025 (0.635).

DIM	INCHES		MILLIMETERS	
	MIN	MAX	MIN	MAX
A	0.785	0.795	19.94	20.19
B	0.785	0.795	19.94	20.19
C	0.165	0.180	4.20	4.57
E	0.090	0.110	2.29	2.79
F	0.013	0.019	0.33	0.48
G	0.050 BSC		1.27 BSC	
H	0.026	0.032	0.66	0.81
J	0.020	—	0.51	—
K	0.025	—	0.64	—
R	0.750	0.756	19.05	19.20
U	0.750	0.756	19.05	19.20
V	0.042	0.048	1.07	1.21
W	0.042	0.048	1.07	1.21
X	0.042	0.056	1.07	1.42
Y	—	0.020	—	0.50
Z	2°	10°	—	10°
G1	0.710	0.730	18.04	18.54
K1	0.040	—	1.02	—

Motorola reserves the right to make changes without further notice to any products herein. Motorola makes no warranty, representation or guarantee regarding the suitability of its products for any particular purpose, nor does Motorola assume any liability arising out of the application or use of any product or circuit, and specifically disclaims any and all liability, including without limitation consequential or incidental damages. "Typical" parameters which may be provided in Motorola data sheets and/or specifications can and do vary in different applications and actual performance may vary over time. All operating parameters, including "Typicals" must be validated for each customer application by customer's technical experts. Motorola does not convey any license under its patent rights nor the rights of others. Motorola products are not designed, intended, or authorized for use as components in systems intended for surgical implant into the body, or other applications intended to support or sustain life, or for any other application in which the failure of the Motorola product could create a situation where personal injury or death may occur. Should Buyer purchase or use Motorola products for any such unintended or unauthorized application, Buyer shall indemnify and hold Motorola and its officers, employees, subsidiaries, affiliates, and distributors harmless against all claims, costs, damages, and expenses, and reasonable attorney fees arising out of, directly or indirectly, any claim of personal injury or death associated with such unintended or unauthorized use, even if such claim alleges that Motorola was negligent regarding the design or manufacture of the part. Motorola and are registered trademarks of Motorola, Inc. Motorola, Inc. is an Equal Opportunity/Affirmative Action Employer.

Mfmx is a trademark of Motorola, Inc.

#### How to reach us:

**USA/EUROPE/Locations Not Listed:** Motorola Literature Distribution;  
P.O. Box 5405, Denver, Colorado, 80217. 1-303-675-2140 or 1-800-441-2447

**Mfax™:** RMFAX0@email.sps.mot.com – TOUCHTONE 1-602-244-6609  
Motorola Fax Back System – US & Canada ONLY 1-800-774-1848  
– http://sps.motorola.com/mfax/

**HOME PAGE:** http://motorola.com/sps/

**JAPAN:** Motorola Japan Ltd.; SPD, Strategic Planning Office, 141,  
4-32-1 Nishi-Gotanda, Shinagawa-ku, Tokyo, Japan. 81-3-5487-8488

**ASIA/PACIFIC:** Motorola Semiconductors H.K. Ltd.; Silicon Harbour Centre,  
2 Dai King Street, Tai Po Industrial Estate, Tao Po, N.T., Hong Kong.  
852-26629298

**CUSTOMER FOCUS CENTER:** 1-800-521-6274



**MOTOROLA**

For More Information On This Product,  
Go to: [www.freescale.com](http://www.freescale.com)

MCM67M618A/D