

MN6475A

D/A Converter for Digital Audio Equipment

■ Overview

The MN6475A is a CMOS digital-to-analog converter by noise shaping technology and is designed for PCM digital audio equipment. It features a built-in 4 times oversampling and 16-bit input digital filter.

It includes a digital de-emphasis circuit and analog post filter to reduce the parts count and power consumption of the overall D/A conversion system.

And also it includes two noise-shaping 1-bit D/A converters, one each for the left and right channels.

■ Features

- Built-in 4 times oversampling digital filter
(Bandwidth ripple of ± 0.051 dB and attenuation of 47.99dB dB)
- Built-in second order analog post filter with a cutoff frequency of 100 kHz
- Built-in digital de-emphasis circuit with a deviation between +0.47 dB and - 0.07 dB
- Choice of normal or double-speed playback
- Built-in overflow limiter
- No zero cross distortion
- Sample-and-hold circuit is unnecessary
- Choice of $768f_s$ or $384f_s$ operation
- Single 5V power supply

■ Applications

- CD players and other digital audio equipment

■ Pin Assignment

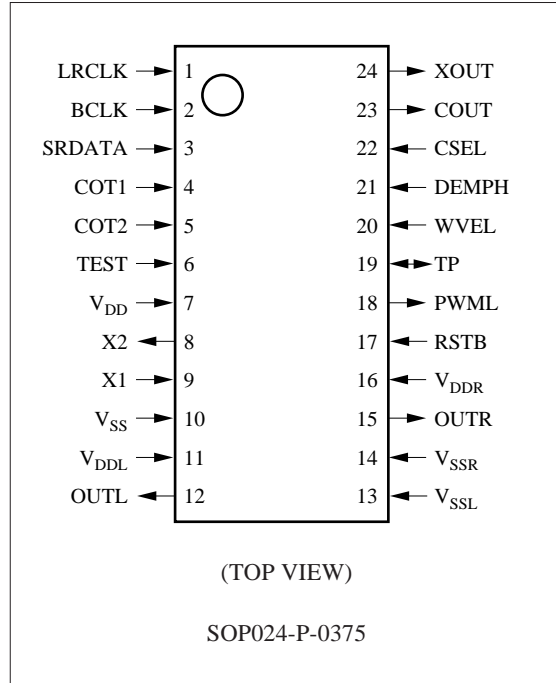

■ Block Diagram

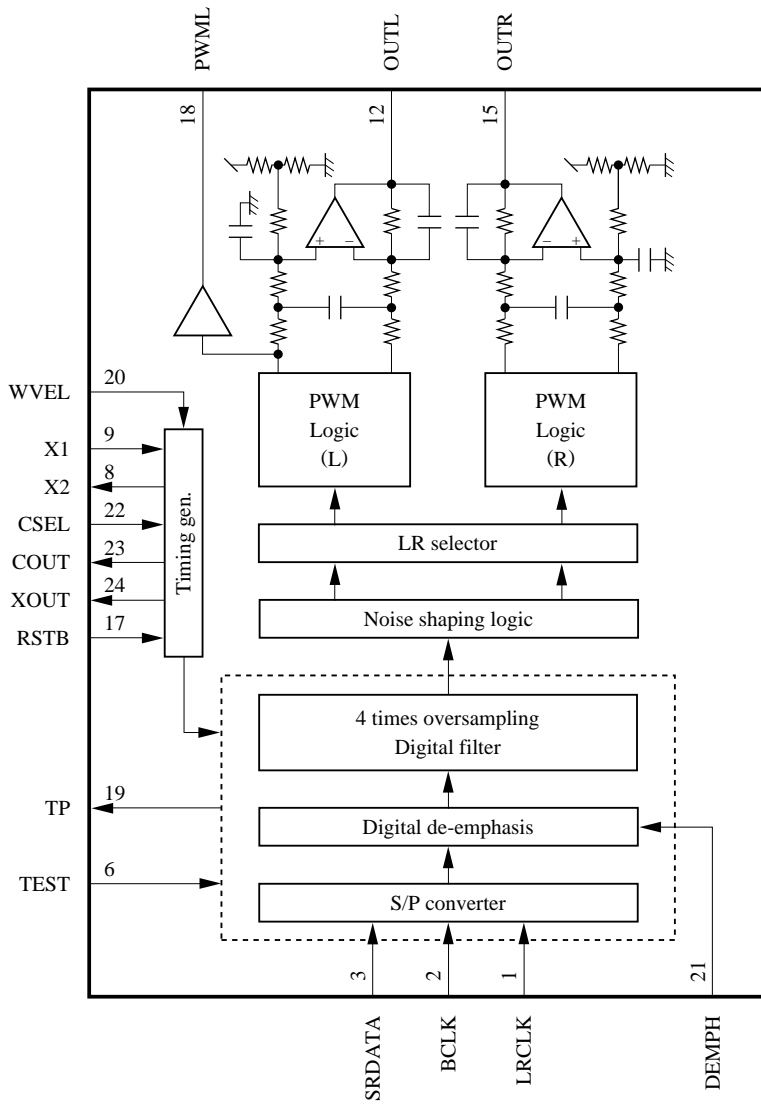

■ Pin Descriptions

Pin No.	Symbol	Function Description							
1	LRCLK	LRCLK input pin. "H" level; left channel data input "L" level; right channel data							
2	BCLK	Bit clock input pin for serial data							
3	SRDATA	Serial data input pin							
4	COT 1	L	Stereo output	L	Left channel output only	H	Right channel output only	H	Output with channels reversed
5	COT2	L		H		L		H	
6	TEST	LSI test mode pin. Keep this pin at "L" level.							
7	V _{DD}	Power supply pin for digital circuits (+5V)							
8	X2	Crystal oscillator pin							
9	X1	Crystal oscillator pin (external clock input pin)							
10	V _{SS}	Ground pin for digital circuits (0V)							
11	V _{DDL}	Power supply pin for left channel analog circuits (+5V)							
12	OUTL	Left channel analog signal output pin							
13	V _{SSL}	Ground pin for left channel analog circuits (0V)							
14	V _{SSR}	Ground pin for right channel analog circuits (0V)							
15	OUTR	Right channel analog signal output pin							
16	V _{DDR}	Power supply pin for right channel digital circuits (+5V)							
17	RSTB	Reset pin (Active low). Pull this pin low once after applying the power.							
18	PWML	LSI test output pin. Leave this pin open.							
19	TP	Input/Output pin for LSI test mode. Keep this pin at "L" level.							
20	WVEL	Internal operation mode selection pin							
21	DEMPH	Digital De-emphasis ON/OFF pin. ON at "H" level.							
22	CSEL	Clock frequency selection pin for COUT pin output. "L" level; 1/4 clock frequency from crystal oscillator or external clock signal "H" level; 1/2 clock frequency							
23	COUT	Frequency-divided clock output							
24	XOUT	Output using frequency from crystal oscillator or external clock signal							

■ Conversion Characteristics

$V_{DD}=5.0V$, $V_{SS}=0V$, $f=33.8688MHz$, $T_a=25^{\circ}C$

Parameter	Symbol	Test Conditions	min	typ	max	Unit
Analog characteristics *1						
Signal-to-noise ratio	S/N	EIAJ	97	104		dB
Dynamic range	D.R.	EIAJ	90	97		dB
Total harmonic distortion	THD+N	EIAJ		0.003	0.006	%
Crosstalk		EIAJ	84	100		dB
Output level 1 *2		1kHz F.S.	2.0	2.3	2.6	V_{rms}
Output level 2 *3		1kHz F.S.	1.0	1.2	1.4	V_{rms}

Notes

*1: These analog characteristics are based on measurements in the application circuit example next page.

*2: This level is measured at point B in that circuit.

*3: This level is measured at point A (LSI output pin) in that circuit.

■ Application Circuit Example

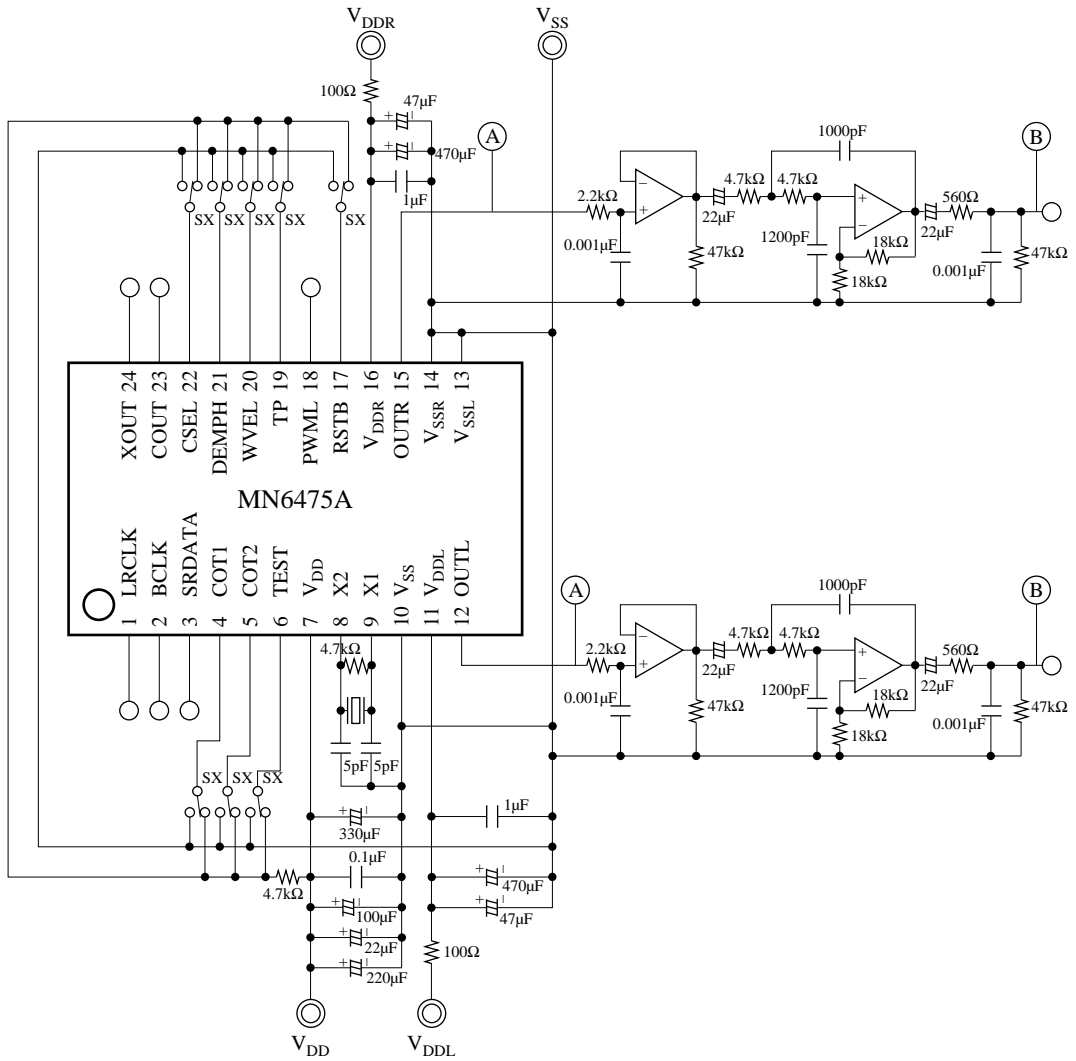

■ Package Dimensions (Unit: mm)

SOP024-P-0375

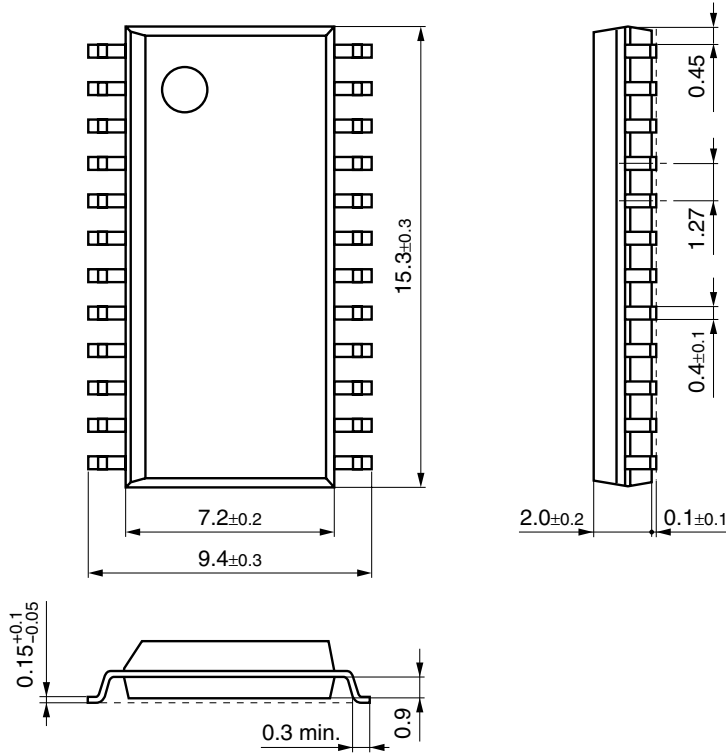

Note) The package of this product will be changed to the following lead-free type (SOP024-P-0375B).

■ New Package Dimensions (Unit: mm)

- SOP024-P-0375B (Lead-free package)

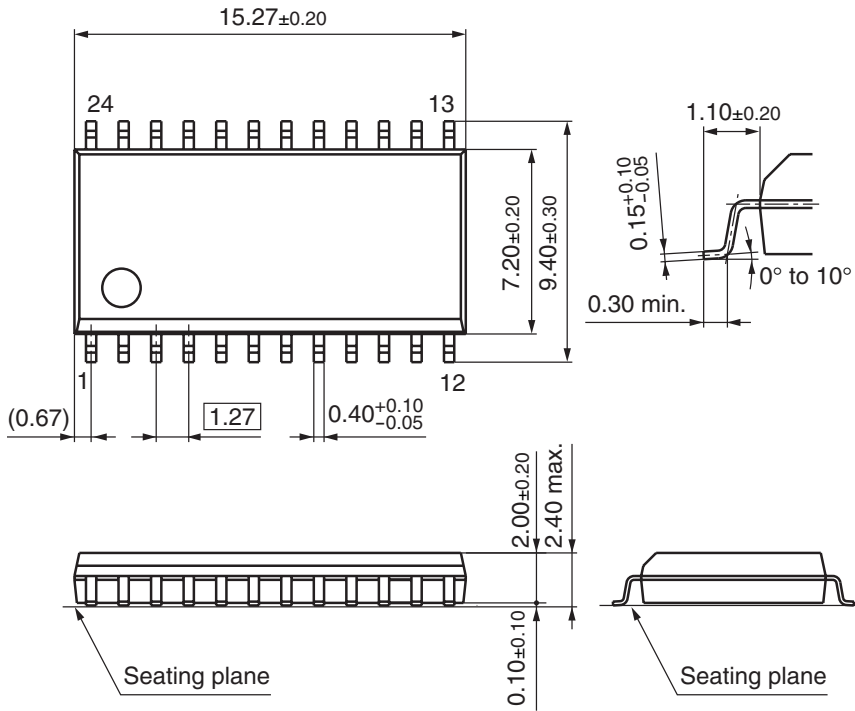

Request for your special attention and precautions in using the technical information and semiconductors described in this material

- (1) An export permit needs to be obtained from the competent authorities of the Japanese Government if any of the products or technologies described in this material and controlled under the "Foreign Exchange and Foreign Trade Law" is to be exported or taken out of Japan.
- (2) The technical information described in this material is limited to showing representative characteristics and applied circuit examples of the products. It does not constitute the warranting of industrial property, the granting of relative rights, or the granting of any license.
- (3) The products described in this material are intended to be used for standard applications or general electronic equipment (such as office equipment, communications equipment, measuring instruments and household appliances).
Consult our sales staff in advance for information on the following applications:
 - Special applications (such as for airplanes, aerospace, automobiles, traffic control equipment, combustion equipment, life support systems and safety devices) in which exceptional quality and reliability are required, or if the failure or malfunction of the products may directly jeopardize life or harm the human body.
 - Any applications other than the standard applications intended.
- (4) The products and product specifications described in this material are subject to change without notice for reasons of modification and/or improvement. At the final stage of your design, purchasing, or use of the products, therefore, ask for the most up-to-date Product Standards in advance to make sure that the latest specifications satisfy your requirements.
- (5) When designing your equipment, comply with the guaranteed values, in particular those of maximum rating, the range of operating power supply voltage and heat radiation characteristics. Otherwise, we will not be liable for any defect which may arise later in your equipment.
Even when the products are used within the guaranteed values, redundant design is recommended, so that such equipment may not violate relevant laws or regulations because of the function of our products.
- (6) When using products for which dry packing is required, observe the conditions (including shelf life and after-unpacking standby time) agreed upon when specification sheets are individually exchanged.
- (7) No part of this material may be reprinted or reproduced by any means without written permission from our company.

Please read the following notes before using the datasheets

- A. These materials are intended as a reference to assist customers with the selection of Panasonic semiconductor products best suited to their applications.
Due to modification or other reasons, any information contained in this material, such as available product types, technical data, and so on, is subject to change without notice.
Customers are advised to contact our semiconductor sales office and obtain the latest information before starting precise technical research and/or purchasing activities.
- B. Panasonic is endeavoring to continually improve the quality and reliability of these materials but there is always the possibility that further rectifications will be required in the future. Therefore, Panasonic will not assume any liability for any damages arising from any errors etc. that may appear in this material.
- C. These materials are solely intended for a customer's individual use.
Therefore, without the prior written approval of Panasonic, any other use such as reproducing, selling, or distributing this material to a third party, via the Internet or in any other way, is prohibited.