

*Advance Information**MPC185TS/D  
Rev. 2.1, 2/2003**MPC185 Security Processor  
Technical Summary*

This technical summary provides an overview of the MPC185 Security Processor, including a brief development history, target applications, key features, typical system architecture, device architectural overview, and a performance summary.

## 1 Development History

The MPC185 belongs to the Smart Networks platform's S1 family of security processors developed for the commercial networking market. This product family is derived from security technologies Motorola has developed over the last 30 years, primarily for government applications. The fifth-generation execution units (EU) have been proven in Motorola semi-custom ICs and in the MPC180 and MPC190, two products in Motorola's security processor line.

## 2 Typical Applications

The MPC185 is suited for applications such as the following:

- Edge routers
- Broadband access equipment
- eCommerce servers
- Wireless base stations
- WAP gateways

## 3 Features

The MPC185 is a flexible and powerful addition to any networking or computing system using the Motorola PowerQUICC II line of integrated communications processors, or any system supporting the 60x bus protocol. The MPC185 is designed to offload computationally intensive security functions, such as key generation and exchange, authentication, and bulk encryption from the host processor with PowerPC architecture.

The MPC185 is optimized to process all the algorithms associated with IPSec, IKE, WTLS/WAP, SSL/TLS and 3GPP. In addition, the Motorola family of security co-processors

are the only devices on the market capable of executing elliptic curve cryptography which is especially important for secure wireless communications.

MPC185 features include the following:

- 2 Public Key Execution Units (PKEUs) that support the following:
  - RSA and Diffie-Hellman
    - Programmable field size up to 2048-bits
  - Elliptic curve cryptography
    - $F_{2^m}$  and  $F(p)$  modes
    - Programmable field size up to 511-bits
- 2 Data Encryption Standard Execution Units (DEUs)
  - DES, 3DES
  - Two key (K1, K2, K1) or Three Key (K1, K2, K3)
  - ECB and CBC modes for both DES and 3DES
- 2 Advanced Encryption Standard Units (AESUs)
  - Implements the Rijndael symmetric key cipher
  - ECB, CBC, and counter modes
  - 128, 192, 256 bit key lengths
- 1 ARC Four Execution Unit (AFEUs)
  - Implements a stream cipher compatible with the RC4 algorithm
  - 40- to 128-bit programmable key
- 2 Message Digest Execution Units (MDEUs)
  - SHA with 160-bit or 256-bit message digest
  - MD5 with 128-bit message digest
  - HMAC with either algorithm
- 1 Kasumi Execution Unit for 3GPP systems (KEUs)
  - Implements F8 algorithm for encryption and F9 algorithm for authentication
- 1 Random number generator (RNGs)
- 60x compliant external bus interface, with master/slave logic
  - 32-bit address/64-bit data
  - Up to 100 MHz operation
- 4 Crypto-channels, each supporting multi-command descriptor chains
  - Static and/or dynamic assignment of crypto-execution units via an integrated controller
  - Buffer size of 512 bytes for each execution unit, with flow control for large data sizes
- 32KB of internal scratchpad memory for key, IV and context storage
- 1.5V supply, 3.3V and 2.5V I/O
- 256 MAP BGA, 17 x 17mm package body size
- 1.5W power dissipation

## 4 Typical System Architecture

The MPC185 is designed to integrate easily into any system using the 60x bus protocol. It is ideal in any system using a Motorola PowerQUICC II communications processor (as shown in Figure 4-1) or a

PowerPC-architected processor and memory controller. The ability of the MPC185 to be a master on the 60x bus allows the co-processor to offload the data movement bottleneck normally associated with slave devices.

The host processor accesses the MPC185 through its device drivers using system memory for data storage. The MPC185 resides in the memory map of the processor, therefore when an application requires cryptographic functions, it simply creates descriptors for the MPC185 which define the cryptographic function to be performed and the location of the data. The MPC185's 60x-mastering capability permits the host processor to set up a crypto-channel with a few short register writes, leaving the MPC185 to perform reads and writes on system memory to complete the required task.

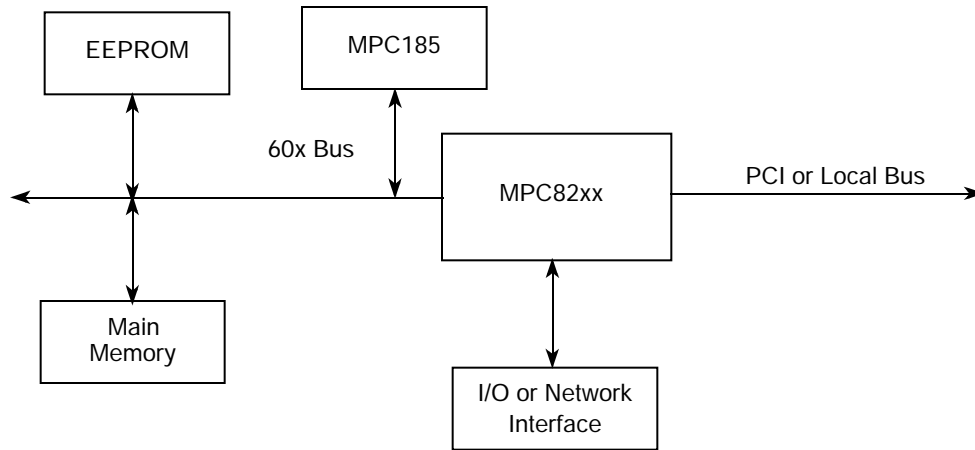

**Figure 4-1. MPC185 Connected to PowerQuicc II 60x Bus**

Figure 4-2 shows a configuration with the MPC185 communicating with the host processor via a PCI bridge, such as the MPC107.

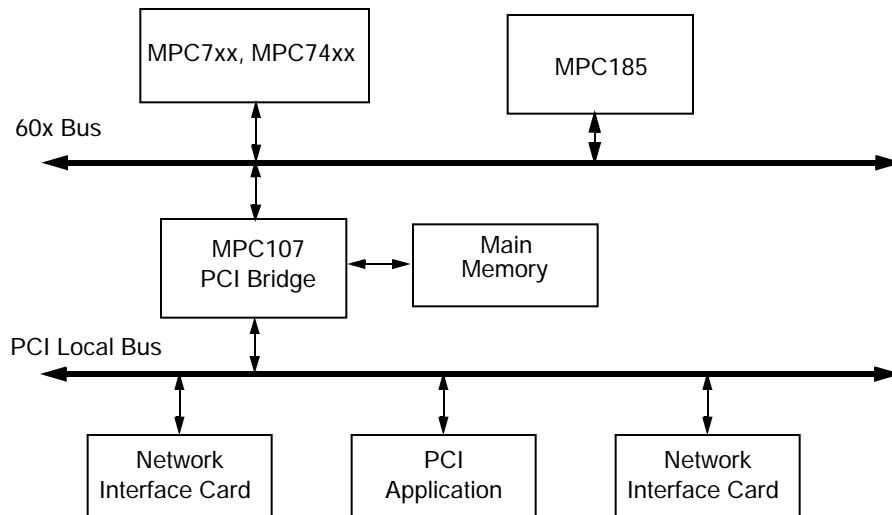

**Figure 4-2. MPC185 Connected to host CPU via a Bridge**

## 5 Architectural Overview

A block diagram of the MPC185 internal architecture is shown in Figure 5-3. The 60x bus interface (60x/IF) module is designed to transfer 64-bit words between the 60x bus and any register inside the MPC185.

An operation begins with a write of a pointer to a crypto-channel fetch register which points to a data packet descriptor. The channel requests the descriptor and decodes the operation to be performed. The channel then requests the controller to assign crypto execution units and fetch the keys, IV's and data needed to perform the given operation. The controller satisfies the requests by assigning execution units to the channel and by making requests to the master interface per the programmable priority scheme. As data is processed, it is written to the individual execution units output buffer and then back to system memory via the 60x/IF module.

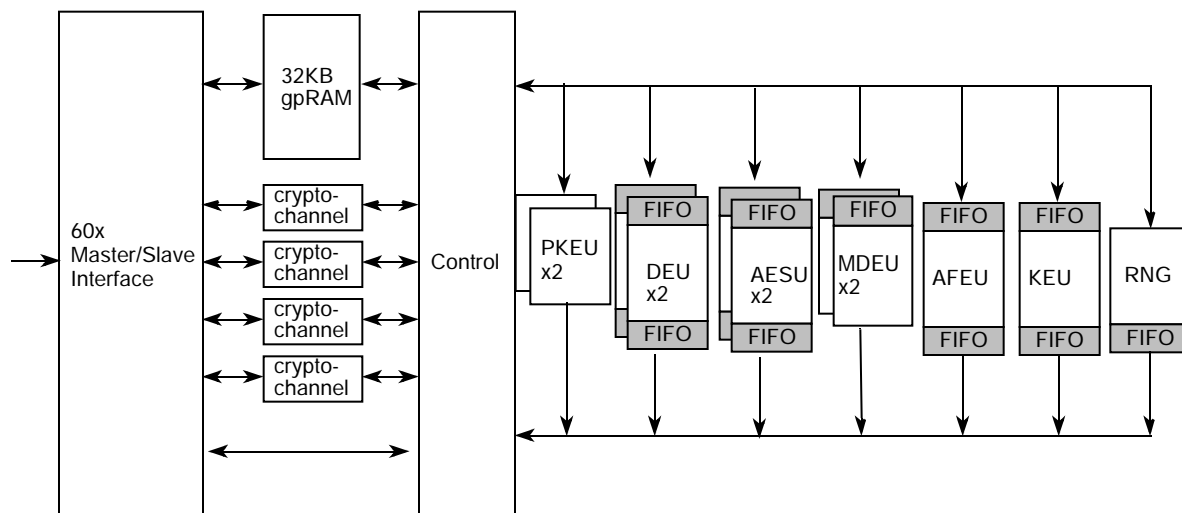

Figure 5-3. MPC185 Functional Blocks

## 6 Data Packet Descriptors

As a crypto accelerator, the MPC185 controller has been designed for easy use and integration with existing systems and software. All cryptographic functions are accessible through data packet descriptors, some of which have been defined as multifunction to facilitate IPSec applications. A data packet descriptor is diagrammed in Table 6-1.

Table 6-1. Example Data Packet Descriptor

Field Name	Value/Type	Description
DPD_DES_CTX_CRYPT	Tbd	Representative header for DES using Context to Encrypt
LEN_CTXIN PTR_CTXIN	Length Pointer	Number of bytes to be written Pointer to Context (IV) to be written into DES engine
LEN_KEY PTR_KEY	Length Pointer	Number of bytes in key Pointer to block cipher key
LEN_DATAIN PTR_DATAIN	Length Pointer	Number of bytes of data to be ciphered Pointer to data to perform cipher upon

**Table 6-1. Example Data Packet Descriptor**

Field Name	Value/Type	Description
LEN_DATAOUT PTR_DATAOUT	Length Pointer	Number of bytes of data after ciphering Pointer to location where cipher output is to be written
LEN_CTXOUT PTR_CTXOUT	Length Pointer	Length of output Context (IV) Pointer to location where altered Context is to be written
Nul length Nul pointer	Length Pointer	Zeroes for fixed length descriptor filter Zeroes for fixed length descriptor filter
Nul length Nul pointer	Length Pointer	Zeroes for fixed length descriptor filter Zeroes for fixed length descriptor filter
PTR_NEXT	Pointer	Pointer to next data packet descriptor

Each data packet descriptor contains the following:

- Header—The header describes the required services and encodes information that indicates which EUs to use and which modes to set.
- Seven data length/data pointer pairs—The data length indicates the number of contiguous bytes of data to be transferred. The data pointer indicates the starting address of the data, key, or context in system memory.
- Next descriptor pointer

A data packet descriptor ends with a pointer to the next data packet descriptor. Upon completion of the current descriptor, this field is checked and, if non-zero, the channel is instructed to request a burst read of the next descriptor.

Processing of the next descriptor (and whether or not a done signal is generated) is determined by the programming of crypto-channel's configuration register. Two modes of operation are supported:

- Signal done at end of descriptor
- Signal done at end of descriptor chain

The crypto-channel can signal done via an interrupt or by a write-back of the descriptor header after processing a data packet descriptor. The value written back is identical to that of the header, with the exception that a DONE field is set.

Occasionally, a descriptor field may not be applicable to the requested service. For example, if using DES in ECB mode, the contents of the IV field do not affect the result of the DES computation. Therefore, when processing data packet descriptors, the crypto-channel skips any pointer that has an associated length of zero.

## 6.1 60x Interface

The 60x interface manages communication between the MPC185 internal execution units and the 60x bus. The interface uses the 60x bus master/slave protocols. All on-chip resources are memory mapped, and the target accesses and initiator writes from the MPC185 must be addressed on word boundaries. The MPC185 will perform initiator reads on byte boundaries and will adjust the data to place on word boundaries as appropriate. Access to system memory is a critical factor in co-processor performance, and the native 60x interface of the MPC185 allows it to achieve performance unattainable on secondary busses.

## 6.2 The MPC185 Controller

The MPC185 controller manages on-chip resources, including the individual execution units (EUs), FIFOs, the 60x Interface, and the internal buses that connect all the various modules. The controller receives service requests from the 60x interface and various crypto-channels, and schedules the required activities. The controller can configure each of the on-chip resources in three modes:

- Host-controlled mode—The host is directly responsible for all data movement into and out of the resource.
- Static mode—The user can reserve a specific execution unit to a specific crypto-channel.
- Dynamic mode—A crypto channel can request a particular service from any available execution unit.

## 6.3 Host-Managed Register Access

All EUs can be used entirely through register read/write access. It is strongly recommended that read/write access only be performed on a EU that is statically assigned to an idle crypto-channel. Such an assignment is the only method for the host to inform the controller that a particular EU is in use.

## 6.4 Static EU Access

The controller can be configured to reserve one or more EUs to a particular crypto-channel. Doing so permits locking the EU to a particular context. When in this mode, the crypto-channel can be used by multiple descriptors representing the same context without unloading and reloading the context at the end of each descriptor. This mode presents considerable performance improvement over dynamic access, but only when the MPC185 is supporting few (or one) contexts.

Static EU access can also be used to reserve one particular Public Key Execution Unit (PKEU) for one type of computation. For example, one PKEU could be reserved for all private key RSA operations using prime P, and the other could be reserved for all computations using prime Q. Again, this presents a performance improvement because all fixed parameters can remain within the reserved PKEUs. This reduces the overhead of loading and unloading contexts and therefore improves performance. However, this is only a performance improvement if the lack of dynamically available PKEUs does not become a bottleneck in key agreement protocols.

## 6.5 Dynamic EU Access

Processing begins when a data packet descriptor pointer is written to the Next Descriptor Pointer Register of one of the crypto-channels. Prior to fetching the data referred to by the descriptor and based on the services requested by the descriptor header in the descriptor buffer, the controller dynamically reserves usage of an EU to the crypto-channel. If all appropriate EUs are already dynamically reserved by other crypto-channels, the crypto-channel stalls and waits to fetch data until an appropriate EU is available.

If multiple crypto-channels simultaneously request the same EU, the EU is assigned on a weighted priority or round-robin basis. Once the required EU has been reserved, the crypto-channel fetches and loads the appropriate data packets, operates the EU, unloads data to system memory, and releases the EU for use by another crypto-channel. If a crypto-channel attempts to reserve a statically-assigned EU (and no appropriate EUs are available for dynamic assignment), an interrupt is generated and status indicates illegal access. When dynamic assignment is used, each encryption/decryption packet must contain context that is particular to the context being supported.

## 6.6 Crypto-Channels

The MPC185 includes four crypto-channels that manage data and EU function. Each crypto-channel consists of the following:

- Control registers containing information about the transaction in process
- A status register containing an indication of the last unfulfilled bus request
- A pointer register indicating the location of a new descriptor to fetch
- Buffer memory used to store the active data packet descriptor

Crypto-channels analyze the data packet descriptor header and requests the first required cryptographic service from the controller. The controller implements a programmable prioritization scheme that allows the user to dictate the order in which the four crypto-channels are serviced. After the controller grants access to the required EU, the crypto-channel and the controller perform the following steps:

1. Set the appropriate mode bits available in the EU for the required service.
2. Fetch context and other parameters as indicated in the data packet descriptor buffer and use these to program the EU.
3. Fetch data as indicated and place in either the EU input FIFO or the EU itself (as appropriate).
4. Wait for EU to complete processing.
5. Upon completion, unload results and context and write them to external memory as indicated by the data packet descriptor buffer.
6. If multiple services requested, go back to step 2.
7. Reset the appropriate EU if it is dynamically assigned. Note that if statically assigned, a EU is reset only upon direct command written to the MPC185.
8. Perform descriptor completion notification as appropriate. This notification comes in one of two forms—interrupt or header writeback modification—and can occur at the end of every descriptor, at the end of a descriptor chain, or at the end of specially designated descriptors within a chain.

## 7 Execution Units (EUs)

‘Execution unit’ is the generic term for a functional block that performs the mathematical permutations required by protocols used in cryptographic processing. The EUs are compatible with IPsec, WAP/WTLS, IKE, SSL/TLS and 3GPP processing, and can work together to perform high level cryptographic tasks. The MPC185 execution units are as follows:

- PKEU for computing asymmetric key operations, including Modular Exponentiation (and other Modular Arithmetic functions) or ECC Point Arithmetic
- DEU for performing block cipher, symmetric key cryptography using DES and 3DES
- AFEU for performing RC-4 compatible stream cipher symmetric key cryptography
- AESU for performing the Advanced Encryption Standard algorithm
- KEU for performing F8 and F9 encryption and authentication
- MDEU for performing security hashing using MD-3, SHA-1, or SHA-256
- RNG for random number generation

### 7.1 Public Key Execution Unit (PKEU)

The PKEU is capable of performing many advanced mathematical functions to support both RSA and ECC public key cryptographic algorithms. ECC is supported in both F(2)<sup>m</sup> (polynomial-basis) and F(p) modes. This EU supports all levels of functions to assist the host microprocessor to perform its desired

cryptographic function. For example, at the highest level, the accelerator performs modular exponentiations to support RSA and performs point multiplies to support ECC. At the lower levels, the PKEU can perform simple operations such as modular multiplies.

### 7.1.1 Elliptic Curve Operations

The PKEU has its own data and control units, including a general-purpose register file in the programmable-size arithmetic unit. The field or modulus size can be programmed to any value between 160 bits and 512 bits in programmable increments of 8, with each programmable value  $i$  supporting all actual field sizes from  $i*8 - 7$  to  $i*8$ . The result is hardware supporting a wide range of cryptographic security. Larger field / modulus sizes result in greater security but lower performance; processing time is determined by field or modulus size. For example, a field size of 160 is roughly equivalent to the security provided by 1024 bit RSA. A field size set to 208 roughly equates to 2048 bits of RSA security.

The PKEU contains routines implementing the atomic functions for elliptic curve processing—point arithmetic and finite field arithmetic. The point operations (multiplication, addition and doubling) involve one or more finite field operations which are addition, multiplication, inverse, and squaring. Point add and double each use of all four finite field operations. Similarly, point multiplication uses all EC point operations as well as the finite field operations. All these functions are supported both in modular arithmetic as well as polynomial basis finite fields.

### 7.1.2 Modular Exponentiation Operations

The PKEU is also capable of performing ordinary integer modulo arithmetic. This arithmetic is an integral part of the RSA public key algorithm; however, it can also play a role in the generation of ECC digital signatures and Diffie-Hellman key exchanges.

Modular arithmetic functions supported by the MPC185's PKEU include the following:

$R \cdot 2 \pmod N$

$A' \cdot E \pmod N$

$(A \times B) R^{-1} \pmod N$

$(A \times B) R^{-2} \pmod N$

$(A + B) \pmod N$

$(A - B) \pmod N$

Where the following variable definitions:  $A' = AR \pmod N$ ,  $N$  is the modulus vector,  $A$  and  $B$  are input vectors,  $E$  is the exponent vector,  $R$  is  $2^s$ , where  $s$  is the bit length of the  $N$  vector rounded up to the nearest multiple of 32.

The PKEU can perform modular arithmetic on operands up to 2048 bits in length. The modulus must be larger than or equal to 129 bits. The PKEU uses the Montgomery modular multiplication algorithm to perform core functions. The addition and subtraction functions exist to help support known methods of the Chinese Remainder Theorem (CRT) for efficient exponentiation.

## 7.2 Data Encryption Standard Execution Unit (DEU)

The DES Execution Unit (DEU) performs bulk data encryption/decryption, in compliance with the Data Encryption Standard algorithm (ANSI x3.92). The DEU can also compute 3DES and extension of the DES



algorithm in which each 64-bit input block is processed three times. The MPC185 supports 2 key (K1=K3) or 3 key 3DES.

The DEU operates by permuting 64-bit data blocks with a shared 56-bit key and an initialization vector (IV). The MPC185 supports two modes of IV operation: Electronic Code Book (ECB) and Cipher Clock Chaining (CBC).

### 7.3 Arc Four Execution Unit (AFEU)

The AFEU accelerates a bulk encryption algorithm compatible with the RC4 stream cipher from RSA Security, Inc. The algorithm is byte-oriented, meaning a byte of plain text is encrypted with a key to produce a byte of ciphertext. The key is variable length and the AFEU supports key lengths from 40 to 128 bits (in byte increments), providing a wide range of security strengths. RC4 is a symmetric algorithm, meaning each of the two communicating parties share the same key.

### 7.4 Advanced Encryption Standard Execution Unit (AESU)

The AESU is used to accelerate bulk data encryption/decryption in compliance with the Advanced Encryption Standard algorithm Rijndael. The AESU executes on 128 bit blocks with a choice of key sizes: 128, 192, or 256 bits.

AESA is a symmetric key algorithm, the sender and receiver use the same key for both encryption and decryption. The session key and IV(CBC mode) are supplied to the AESU module prior to encryption. The processor supplies data to the module that is processed as 128 bit input. The AESU operates in ECB, CBC, and counter modes.

### 7.5 Kasumi Execution Unit (KEU)

The KEU is used to accelerate two algorithms defined in the 3GPP architecture, a confidentiality algorithm (f8) and an integrity algorithm (f9). Each of these algorithms is based on the Kasumi algorithm. Kasumi is a block cipher that produces a 64-bit output from a 64-bit input under the control of a 128-bit key. The confidentiality algorithm f8 is a stream cipher that is used to encrypt/decrypt blocks of data under a confidentiality key. The block of data may be between 1 and 5114 bits long. The algorithm uses Kasumi in a form of output-feedback mode as a keystream generator. The integrity algorithm f9 computes a 32-bit message authentication code (MAC) of a given input message using an integrity key. The approach adopted uses Kasumi in a form of CBC-MAC mode.

### 7.6 Message Digest Execution Unit (MDEU)

The MDEU computes a single message digest (or hash or integrity check) value of all the data presented on the input bus, using either the MD5, SHA-1 or SHA-256 algorithms for bulk data hashing. With any hash algorithm, the larger message is mapped onto a smaller output space, therefore collisions are potential, albeit not probable. The 160-bit hash value is a sufficiently large space such that collisions are extremely rare. The security of the hash function is based on the difficulty of locating collisions. That is, it is computation infeasible to construct two distinct but similar messages that produce the same hash output.

- The MD5 generates a 128-bit hash, and the algorithm is specified in RFC 1321.
- SHA-1 is a 160-bit hash function, specified by the ANSI X9.30-2 and FIPS 180-1 standards.
- SHA-256 is a 256-bit hash function that provides 256 bits of security against collision attacks.
- The MDEU also supports HMAC computations, as specified in RFC 2104.

## 7.7 Random Number Generator (RNG)

The RNG is a digital integrated circuit capable of generating 32-bit random numbers. It is designed to comply with FIPS 140-1 standards for randomness and non-determinism.

Because many cryptographic algorithms use random numbers as a source for generating a secret value (a nonce), it is desirable to have a private RNG for use by the MPC185. The anonymity of each random number must be maintained, as well as the unpredictability of the next random number. The FIPS-140 ‘common criteria’ compliant private RNG allows the system to develop random challenges or random secret keys. The secret key can thus remain hidden from even the high-level application code, providing an added measure of physical security.

## 7.8 32KB General Purpose RAM (gpRAM)

The MPC185 contains 32KB of internal general purpose RAM that can be used to store keys, IVs and data. The internal scratchpad allows the user to store frequently used context on chip which increases system performance by minimizing setup time. This feature is especially important when dealing with small packets and in systems where bus bandwidth is limited.

## 8 Performance Estimates

Bulk encryption/authentication performance estimates shown in Table 8-1 include data/key/context reads (from memory to MPC185), security processing (internal to MPC185), and writes of completed data/context to memory by MPC185, using typical 60x system overhead.

**Table 8-1. Estimated Bulk Data Encryption Performance (Mbps)**

	DES CBC	3DES CBC	AES 128	AES 256	ARC4	MD5	SHA-1	Kasumi	3DES/ HMAC- SHA-1(Rx)
64 byte	204	168	180	153	102	177	162	93	138
128 byte	355	260	281	239	176	311	279	104	237
256 byte	562	358	391	332	279	472	411	230	350
512 byte	815	449	489	415	404	636	540	316	459
1024 byte	1051	513	557	473	521	770	639	391	544
1536 byte	1164	538	585	497	595	828	681	426	579

The MPC185 supports single pass processing of encryption/message authentication. All performance measurements assume standard memory latency, and unconstrained use of an 83Mhz, 64-bit bus utilizing the 60x bus protocol.

## 9 Revision History

Table 9-1 summarizes the revision history of this document.



**Table 9-1. Revision History**

<b>Revision No.</b>	<b>Substantive Change(s)</b>
0-0.1	Initial release.
1	Added a Counter Mode. Added revision history.
2	Revised performance estimates for ARC4 and Kasumi.
2.1	Updated with new template



## HOW TO REACH US:

### USA/EUROPE/LOCATIONS NOT LISTED:

Motorola Literature Distribution  
P.O. Box 5405, Denver, Colorado 80217  
1-303-675-2140  
(800) 441-2447

### JAPAN:

Motorola Japan Ltd.  
SPS, Technical Information Center  
3-20-1, Minami-Azabu Minato-ku  
Tokyo 106-8573 Japan  
81-3-3440-3569

### ASIA/PACIFIC:

Motorola Semiconductors H.K. Ltd.  
Silicon Harbour Centre, 2 Dai King Street  
Tai Po Industrial Estate, Tai Po, N.T., Hong Kong  
852-26668334

### TECHNICAL INFORMATION CENTER:

(800) 521-6274

### HOME PAGE:

[www.motorola.com/semiconductors](http://www.motorola.com/semiconductors)

Information in this document is provided solely to enable system and software implementers to use Motorola products. There are no express or implied copyright licenses granted hereunder to design or fabricate any integrated circuits or integrated circuits based on the information in this document.

Motorola reserves the right to make changes without further notice to any products herein.

Motorola makes no warranty, representation or guarantee regarding the suitability of its products for any particular purpose, nor does Motorola assume any liability arising out of the application or use of any product or circuit, and specifically disclaims any and all liability, including without limitation consequential or incidental damages. "Typical" parameters which may be provided in Motorola data sheets and/or specifications can and do vary in different applications and actual performance may vary over time. All operating parameters, including "Typicals" must be validated for each customer application by customer's technical experts. Motorola does not convey any license under its patent rights nor the rights of others. Motorola products are not designed, intended, or authorized for use as components in systems intended for surgical implant into the body, or other applications intended to support or sustain life, or for any other application in which the failure of the Motorola product could create a situation where personal injury or death may occur. Should Buyer purchase or use Motorola products for any such unintended or unauthorized application, Buyer shall indemnify and hold Motorola and its officers, employees, subsidiaries, affiliates, and distributors harmless against all claims, costs, damages, and expenses, and reasonable attorney fees arising out of, directly or indirectly, any claim of personal injury or death associated with such unintended or unauthorized use, even if such claim alleges that Motorola was negligent regarding the design or manufacture of the part.

Motorola and the Stylized M Logo are registered in the U.S. Patent and Trademark Office. digital dna is a trademark of Motorola, Inc. All other product or service names are the property of their respective owners. Motorola, Inc. is an Equal Opportunity/Affirmative Action Employer.

© Motorola, Inc. 2003

MPC185TS/D

**For More Information On This Product,  
Go to: [www.freescale.com](http://www.freescale.com)**