



MPC506A
MPC507A

Single-Ended 16-Channel/Differential 8-Channel CMOS ANALOG MULTIPLEXERS

FEATURES

- ANALOG OVERVOLTAGE PROTECTION: 70Vp-p
- NO CHANNEL INTERACTION DURING OVERVOLTAGE
- BREAK-BEFORE-MAKE SWITCHING
- ANALOG SIGNAL RANGE: $\pm 15V$
- STANDBY POWER: 7.5mW typ
- TRUE SECOND SOURCE

DESCRIPTION

The MPC506A is a 16-channel single-ended analog multiplexer, and the MPC507A is an 8-channel differential multiplexer.

The MPC506A and MPC507A multiplexers have input overvoltage protection. Analog input voltages may exceed either power supply voltage without damaging the device or disturbing the signal path of other channels. The protection circuitry assures that signal fidelity is maintained even under fault conditions that would destroy other multiplexers. Analog inputs can withstand 70Vp-p signal levels and standard ESD tests. Signal sources are protected from short circuits should multiplexer power loss occur; each input presents a 1k Ω resistance under this condition. Digital inputs can also sustain continuous faults up to 4V greater than either supply voltage.

These features make the MPC506A and MPC507A ideal for use in systems where the analog signals originate from external equipment or separately powered sources.

The MPC506A and MPC507A are fabricated with Burr-Brown's dielectrically isolated CMOS technology. The multiplexers are available in plastic DIP and plastic SOIC packages. Temperature range is $-40/+85^{\circ}C$.

FUNCTIONAL DIAGRAMS

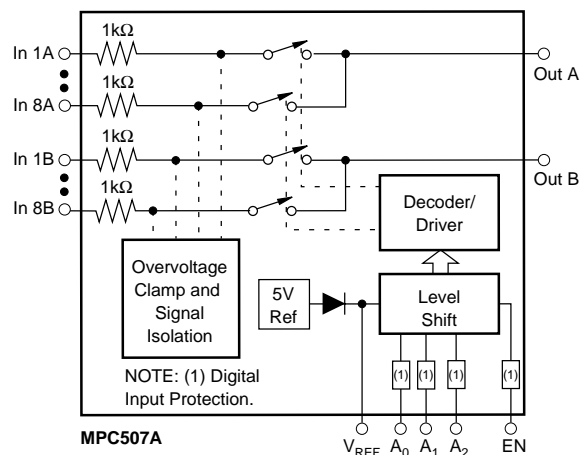
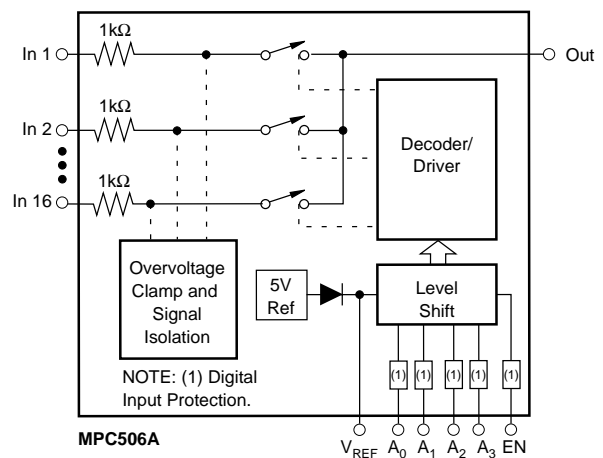

International Airport Industrial Park • Mailing Address: PO Box 11400, Tucson, AZ 85734 • Street Address: 6730 S. Tucson Blvd., Tucson, AZ 85706 • Tel: (520) 746-1111 • Twx: 910-952-1111
Internet: <http://www.burr-brown.com/> • FAXLine: (800) 548-6133 (US/Canada Only) • Cable: BBRCORP • Telex: 066-6491 • FAX: (520) 889-1510 • Immediate Product Info: (800) 548-6132

SPECIFICATIONS

Supplies = +15V, -15V; V_{REF} (Pin 13) = Open; V_{AH} (Logic Level High) = +4.0V; V_{AL} (Logic Level Low) = +0.8V unless, otherwise specified.

| PARAMETER | TEMP | MPC506A/MPC507A | | | UNITS |
|--|-------|-----------------|-----|-----|-------|
| | | MIN | TYP | MAX | |
| ANALOG CHANNEL CHARACTERISTICS | | | | | |
| V _S , Analog Signal Range | Full | -15 | | +15 | V |
| R _{ON} , On Resistance ⁽¹⁾ | +25°C | | 1.3 | 1.5 | kΩ |
| | Full | | 1.5 | 1.8 | kΩ |
| I _S (OFF), Off Input Leakage Current | +25°C | | 0.5 | | nA |
| | Full | | | 10 | nA |
| I _D (OFF), Off Output Leakage Current | +25°C | | 0.2 | | nA |
| MPC506A | Full | | | 5 | nA |
| MPC507A | Full | | | 5 | nA |
| I _D (OFF) with Input Overvoltage Applied ⁽²⁾ | +25°C | | 4.0 | | nA |
| | Full | | | | μA |
| I _D (ON), On Channel Leakage Current | +25°C | | 2 | | nA |
| MPC506A | Full | | | 10 | nA |
| MPC507A | Full | | | 10 | nA |
| I _{DIFF} Differential Off Output Leakage Current (MPC507A Only) | Full | | | 10 | nA |
| DIGITAL INPUT CHARACTERISTICS | | | | | |
| V _{AL} , Input Low Threshold | Full | | | 0.8 | V |
| V _{AH} , Input High Threshold ⁽³⁾ | Full | 4.0 | | | V |
| V _{AL} , MOS Drive ⁽⁴⁾ | +25°C | | | 0.8 | V |
| V _{AH} , MOS Drive ⁽⁴⁾ | +25°C | 6.0 | | | V |
| I _A , Input Leakage Current (High or Low) ⁽⁵⁾ | Full | | | 1.0 | μA |
| SWITCHING CHARACTERISTICS | | | | | |
| t _A , Access Time | +25°C | | 0.3 | | μs |
| | Full | | | 0.6 | μs |
| t _{OPEN} , Break-Before-Make Delay | +25°C | 25 | 80 | | ns |
| t _{ON} (EN), Enable Delay (ON) | +25°C | | 200 | | ns |
| | Full | | | 500 | ns |
| t _{OFF} (EN), Enable Delay (OFF) | +25°C | | 250 | | ns |
| | Full | | | 500 | ns |
| Settling Time (0.1%) | +25°C | | 1.2 | | μs |
| (0.01%) | +25°C | | 3.5 | | μs |
| "OFF Isolation" ⁽⁶⁾ | +25°C | 50 | 68 | | dB |
| C _S (OFF), Channel Input Capacitance | +25°C | | 5 | | pF |
| C _D (OFF), Channel Output Capacitance: MPC506A | +25°C | | 50 | | pF |
| MPC507A | +25°C | | 25 | | pF |
| C _A , Digital Input Capacitance | 25°C | | 5 | | pF |
| C _{DS} , (OFF), Input to Output Capacitance | +25°C | | 0.1 | | pF |
| POWER REQUIREMENTS | | | | | |
| P _D , Power Dissipation | Full | | 7.5 | | mW |
| I ₊ , Current Pin 1 ⁽⁷⁾ | Full | | 0.7 | 1.5 | mA |
| I ₋ , Current Pin 27 ⁽⁷⁾ | Full | | 5 | 20 | μA |

NOTES: (1) V_{OUT} = ±10V, I_{OUT} = -100μA. (2) Analog overvoltage = ±33V. (3) To drive from DTL/TTL circuits. 1kΩ pull-up resistors to +5.0V supply are recommended. (4) V_{REF} = +10V. (5) Digital input leakage is primarily due to the clamp diodes. Typical leakage is less than 1nA at 25°C. (6) V_{EN} = 0.8V, R_L = 1kΩ, C_L = 15pF, V_S = 7Vrms, f = 100kHz. Worst-case isolation occurs on channel 8 due to proximity of the output pins. (7) V_{EN}, V_A = 0V or 4.0V.

The information provided herein is believed to be reliable; however, BURR-BROWN assumes no responsibility for inaccuracies or omissions. BURR-BROWN assumes no responsibility for the use of this information, and all use of such information shall be entirely at the user's own risk. Prices and specifications are subject to change without notice. No patent rights or licenses to any of the circuits described herein are implied or granted to any third party. BURR-BROWN does not authorize or warrant any BURR-BROWN product for use in life support devices and/or systems.



PIN CONFIGURATION

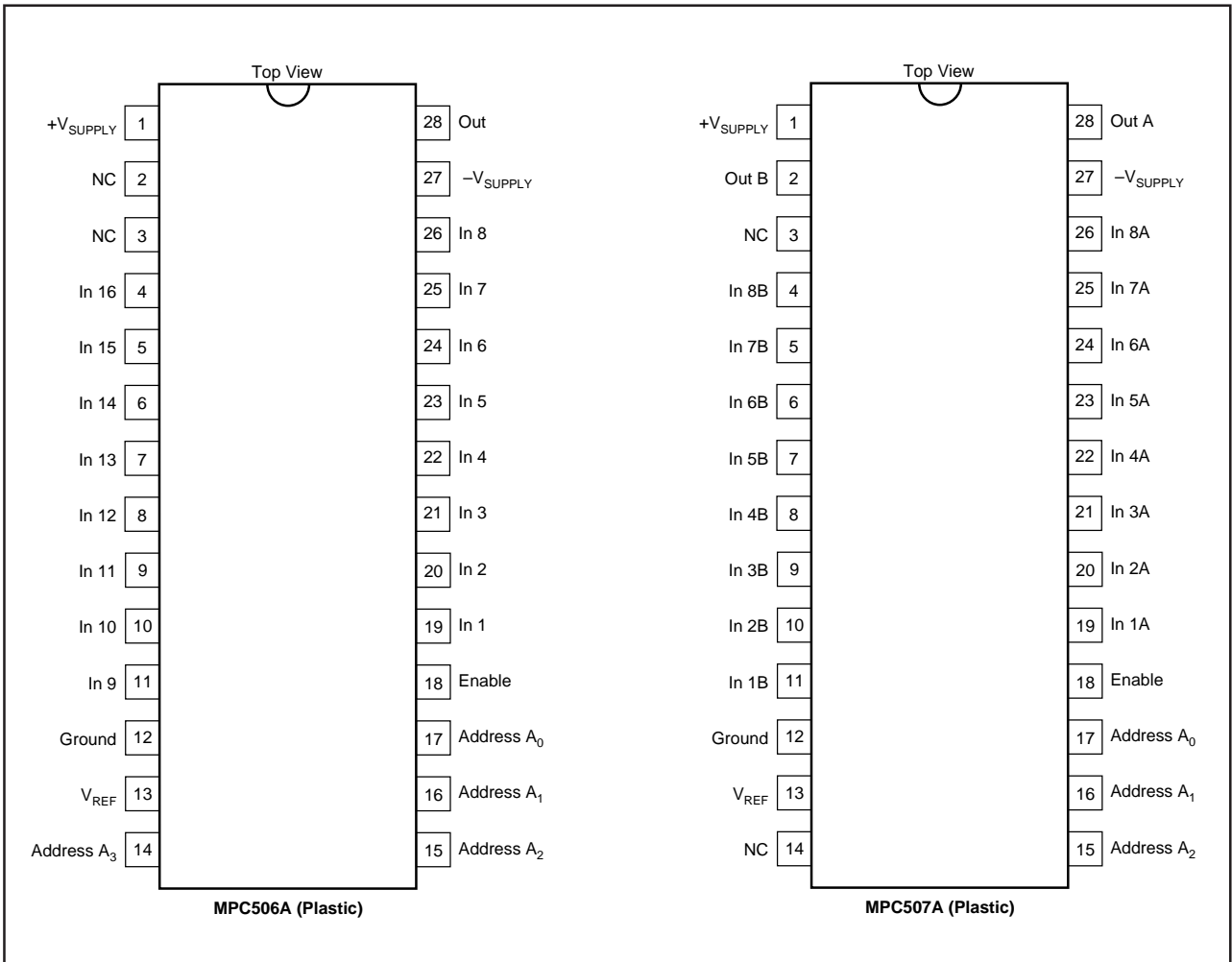

TRUTH TABLES

MPC506A

| A ₃ | A ₂ | A ₁ | A ₀ | EN | "ON" CHANNEL |
|----------------|----------------|----------------|----------------|----|--------------|
| X | X | X | X | L | None |
| L | L | L | L | H | 1 |
| L | L | L | H | H | 2 |
| L | L | H | L | H | 3 |
| L | L | H | H | H | 4 |
| L | H | L | L | H | 5 |
| L | H | L | H | H | 6 |
| L | H | H | L | H | 7 |
| L | H | H | H | H | 8 |
| H | L | L | L | H | 9 |
| H | L | L | H | H | 10 |
| H | L | H | L | H | 11 |
| H | L | H | H | H | 12 |
| H | H | L | L | H | 13 |
| H | H | L | H | H | 14 |
| H | H | H | L | H | 15 |
| H | H | H | H | H | 16 |

MPC507A

| A ₂ | A ₁ | A ₀ | EN | "ON" CHANNEL PAIR |
|----------------|----------------|----------------|----|-------------------|
| X | X | X | L | None |
| L | L | L | H | 1 |
| L | L | H | H | 2 |
| L | H | L | H | 3 |
| L | H | H | H | 4 |
| H | L | L | H | 5 |
| H | L | H | H | 6 |
| H | H | L | H | 7 |
| H | H | H | H | 8 |

PACKAGE INFORMATION

| PRODUCT | PACKAGE | PACKAGE DRAWING NUMBER ⁽¹⁾ |
|----------|---------------------|---------------------------------------|
| MPC506AP | 28-Pin Plastic | 215 |
| MPC506AU | 28-Pin Plastic SOIC | 217 |
| MPC507AP | 28-Pin Plastic | 215 |
| MPC507AU | 28-Pin Plastic SOIC | 217 |

NOTE: (1) For detailed drawing and dimension table, please see end of data sheet, or Appendix C of Burr-Brown IC Data Book.

ABSOLUTE MAXIMUM RATINGS⁽¹⁾

| | |
|--|-----------------|
| Voltage between supply pins | 44V |
| V _{REF} to ground, V+ to ground | 22V |
| V- to ground | 25V |
| Digital input overvoltage: | |
| V _{EN} , V _A : V _{SUPPLY} (+) | +4V |
| V _{SUPPLY} (-) | -4V |
| or 20mA, whichever occurs first. | |
| Analog input overvoltage: | |
| V _S : V _{SUPPLY} (+) | +20V |
| V _{SUPPLY} (-) | -20V |
| Continuous current, S or D | 20mA |
| Peak current, S or D | |
| (pulsed at 1ms, 10% duty cycle max) | 40mA |
| Power dissipation* | 2.0W |
| Operating temperature range | -40°C to +85°C |
| Storage temperature range | -65°C to +150°C |

*Derate 20.0mW/°C above T_A = 70

NOTE: (1) Absolute maximum ratings are limiting values, applied individually, beyond which the serviceability of the circuit may be impaired. Functional operation under any of these conditions is not necessarily implied.

ORDERING INFORMATION

| PRODUCT | PACKAGE | TEMPERATURE RANGE | DESCRIPTION |
|----------|---------------------|-------------------|-------------------------|
| MPC506AP | 28-Pin Plastic DIP | -40°C to +85°C | 16-Channel Single-Ended |
| MPC506AU | 28-Pin Plastic SOIC | -40°C to +85°C | 16-Channel Single-Ended |
| MPC507AP | 28-Pin Plastic DIP | -40°C to +85°C | 8-Channel Differential |
| MPC507AU | 28-Pin Plastic SOIC | -40°C to +85°C | 8-Channel Differential |

TYPICAL PERFORMANCE CURVES

T_A = +25°C, unless otherwise noted.

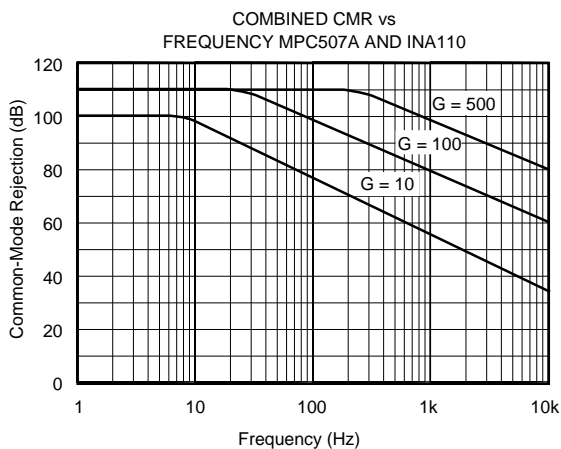
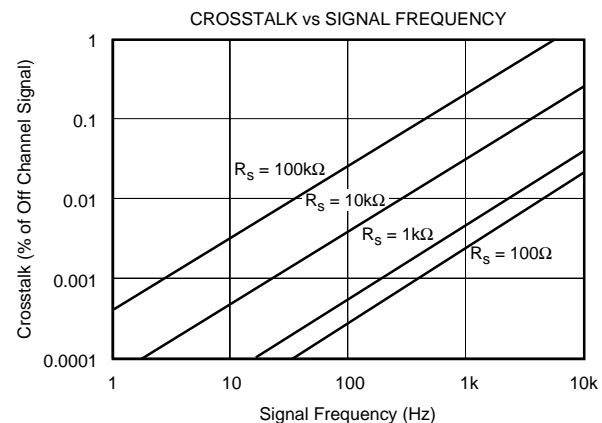
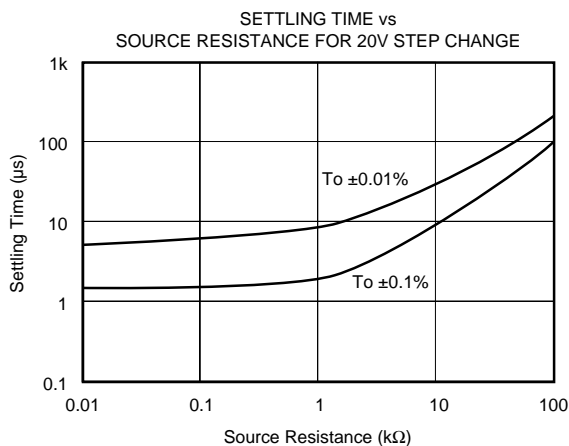

DISCUSSION OF SPECIFICATIONS

DC CHARACTERISTICS

The static or dc transfer accuracy of transmitting the multiplexer input voltage to the output depends on the channel ON resistance (R_{ON}), the load impedance, the source impedance, the load bias current and the multiplexer leakage current.

Single-Ended Multiplexer Static Accuracy

The major contributors to static transfer accuracy for single-ended multiplexers are:

- Source resistance loading error
- Multiplexer ON resistance error
- dc offset error caused by both load bias current and multiplexer leakage current.

Resistive Loading Errors

The source and load impedances will determine the input resistive loading errors. To minimize these errors:

- *Keep loading impedance as high as possible.* This minimizes the resistive loading effects of the source resistance and multiplexer ON resistance. As a guideline, load impedance of $10^8\Omega$ or greater will keep resistive loading errors to 0.002% or less for 1000Ω source impedances. A $10^6\Omega$ load impedance will increase source loading error to 0.2% or more.
- *Use sources with impedances as low as possible.* A 1000Ω source resistance will present less than 0.001% loading error and $10k\Omega$ source resistance will increase source loading error to 0.01% with a 10^8 load impedance.

Input resistive loading errors are determined by the following relationship (see Figure 1).

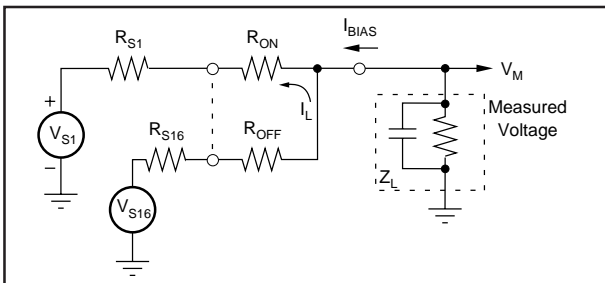

FIGURE 1. MPC506A Static Accuracy Equivalent Circuit.

Source and Multiplexer Resistive Loading Error

$$\epsilon_{(R_S + R_{ON})} = \frac{R_S + R_{ON}}{R_S + R_{ON} + R_L} \times 100\%$$

where R_S = source resistance

R_L = load resistance

R_{ON} = multiplexer ON resistance

Input Offset Voltage

Bias current generates an input OFFSET voltage as a result of the IR drop across the multiplexer ON resistance and source resistance. A load bias current of 10nA will generate an offset voltage of 20 μ V if a 1k Ω source is used. In general, for the MPC506A, the OFFSET voltage at the output is determined by:

$$V_{\text{OFFSET}} = (I_B + I_L) (R_{ON} + R_S)$$

where I_B = Bias current of device multiplexer is driving

I_L = Multiplexer leakage current

R_{ON} = Multiplexer ON resistance

R_S = Source resistance

Differential Multiplexer Static Accuracy

Static accuracy errors in a differential multiplexer are difficult to control, especially when it is used for multiplexing low-level signals with full-scale ranges of 10mV to 100mV.

The matching properties of the multiplexer, source and output load play a very important part in determining the transfer accuracy of the multiplexer. The source impedance unbalance, common-mode impedance, load bias current mismatch, load differential impedance mismatch, and common-mode impedance of the load all contribute errors to the multiplexer. The multiplexer ON resistance mismatch, leakage current mismatch and ON resistance also contribute to differential errors.

Referring to Figure 2, the effects of these errors can be minimized by following the general guidelines described in this section, especially for low-level multiplexing applications.

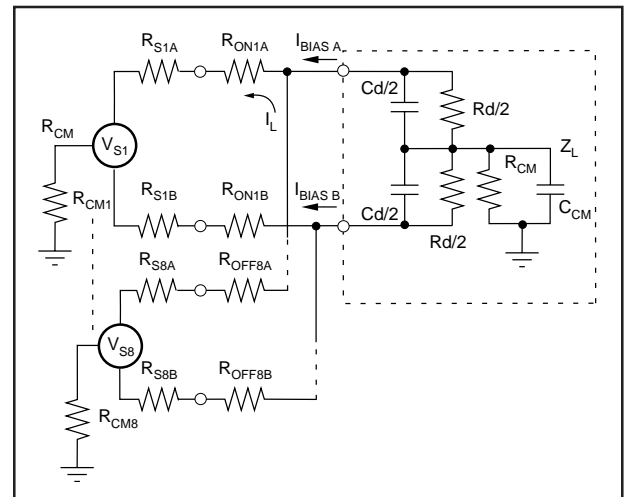

FIGURE 2. MPC507A Static Accuracy Equivalent Circuit.

Load (Output Device) Characteristics

- *Use devices with very low bias current.* Generally, FET input amplifiers should be used for low-level signals less than 50mV FSR. Low bias current bipolar input amplifiers are acceptable for signal ranges higher than 50mV FSR. Bias current matching will determine the input offset.
- The system dc common-mode rejection (CMR) can never be better than the combined CMR of the multiplexer and driven load. System CMR will be less than the device which has the lower CMR figure.
- Load impedances, differential and common-mode, should be $10^{10}\Omega$ or higher.

SOURCE CHARACTERISTICS

- The source impedance unbalance will produce offset, common-mode and channel-to-channel gain-scatter errors. Use sources which do not have large impedance unbalances if at all possible.
- Keep source impedances as low as possible to minimize resistive loading errors.
- Minimize ground loops. If signal lines are shielded, ground all shields to a common point at the system analog common.

If the MPC507A is used for multiplexing high-level signals of 1V to 10V full-scale ranges, the foregoing precautions should still be taken, but the parameters are not as critical as for low-level signal applications.

DYNAMIC CHARACTERISTICS

Settling Time

The gate-to-source and gate-to-drain capacitance of the CMOS FET switches, the RC time constants of the source and the load determine the settling time of the multiplexer.

Governed by the charge transfer relation $i = C (dV/dt)$, the charge currents transferred to both load and source by the analog switches are determined by the amplitude and rise time of the signal driving the CMOS FET switches and the gate-to-drain and gate-to-source junction capacitances as shown in Figures 3 and 4. Using this relationship, one can

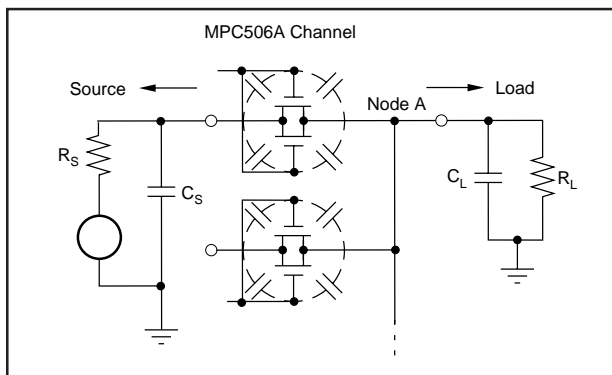

FIGURE 3. Settling Time Effects—MPC506A.

see that the amplitude of the switching transients seen at the source and load decrease proportionally as the capacitance of the load and source increase. The trade-off for reduced switching transient amplitude is increased settling time. In effect, the amplitude of the transients seen at the source and load are:

$$dV_L = (i/C) dt$$

where $i = C (dV/dt)$ of the CMOS FET switches

$C =$ load or source capacitance

The source must then redistribute this charge, and the effect of source resistance on settling time is shown in the Typical Performance Curves. This graph shows the settling time for a 20V step change on the input. The settling time for smaller step changes on the input will be less than that shown in the curve.

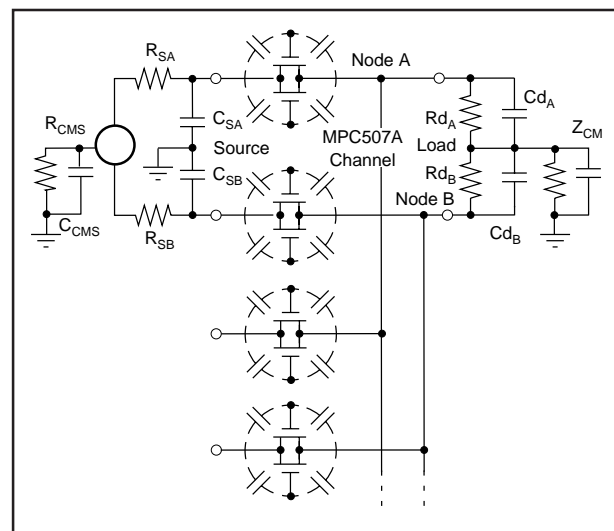

FIGURE 4. Settling and Common-Mode Effects—MPC507A

Switching Time

This is the time required for the CMOS FET to turn ON after a new digital code has been applied to the Channel Address inputs. It is measured from the 50 percent point of the address input signal to the 90 percent point of the analog signal seen at the output for a 10V signal change between channels.

Crosstalk

Crosstalk is the amount of signal feedthrough from the seven (MPC507A) or 15 (MPC506A) OFF channels appearing at the multiplexer output. Crosstalk is caused by the voltage divider effect of the OFF channel, OFF resistance and junction capacitances in series with the R_{ON} and R_S impedances of the ON channel. Crosstalk is measured with a 20Vp-p 1000Hz sine wave applied to all off channels. The crosstalk for these multiplexers is shown in the Typical Performance Curves.

Common-Mode Rejection (MPC507A Only)

The matching properties of the load, multiplexer and source affect the common-mode rejection (CMR) capability of a differentially multiplexed system. CMR is the ability of the multiplexer and input amplifier to reject signals that are common to both inputs, and to pass on only the signal difference to the output. For the MPC507A, protection is provided for common-mode signals of $\pm 20V$ above the power supply voltages with no damage to the analog switches.

The CMR of the MPC507A and Burr-Brown's INA110 instrumentation amplifier ($G = 100$) is 110dB at DC to 10Hz with a 6dB/octave roll-off to 70dB at 1000Hz. This measurement of CMR is shown in the Typical Performance Curves and is made with a Burr-Brown INA110 instrumentation amplifier connected for gains of 500, 100, and 10.

Factors which will degrade multiplexer and system DC CMR are:

- Amplifier bias current and differential impedance mismatch
- Load impedance mismatch
- Multiplexer impedance and leakage current mismatch
- Load and source common-mode impedance

AC CMR roll-off is determined by the amount of common-mode capacitances (absolute and mismatch) from each signal line to ground. Larger capacitances will limit CMR at higher frequencies; thus, if good CMR is desired at higher frequencies, the common-mode capacitances and unbalance of signal lines and multiplexer to amplifier wiring must be minimized. Use twisted-shielded pair signal lines wherever possible.

SWITCHING WAVEFORMS

Typical at +25°C, unless otherwise noted.

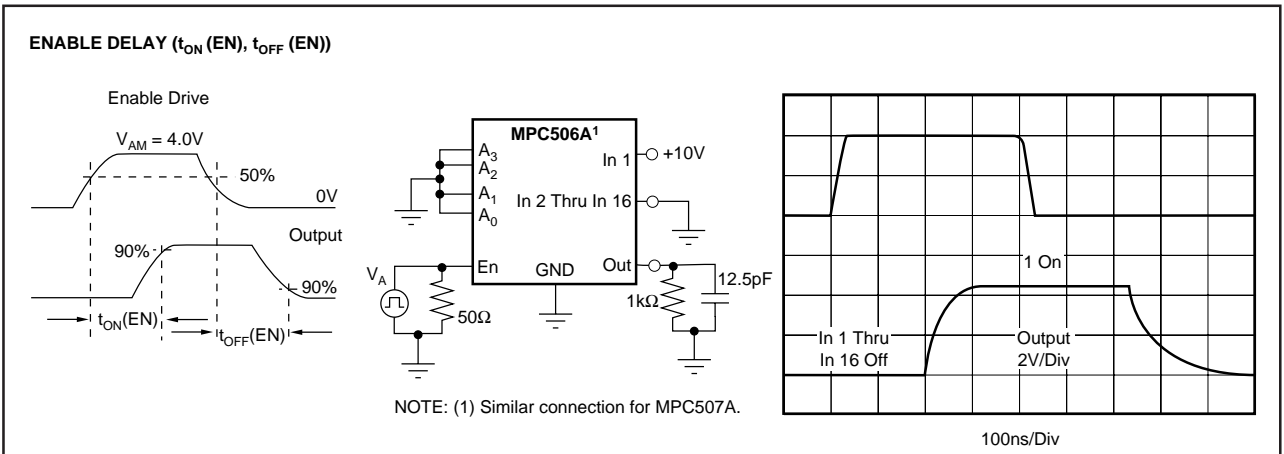
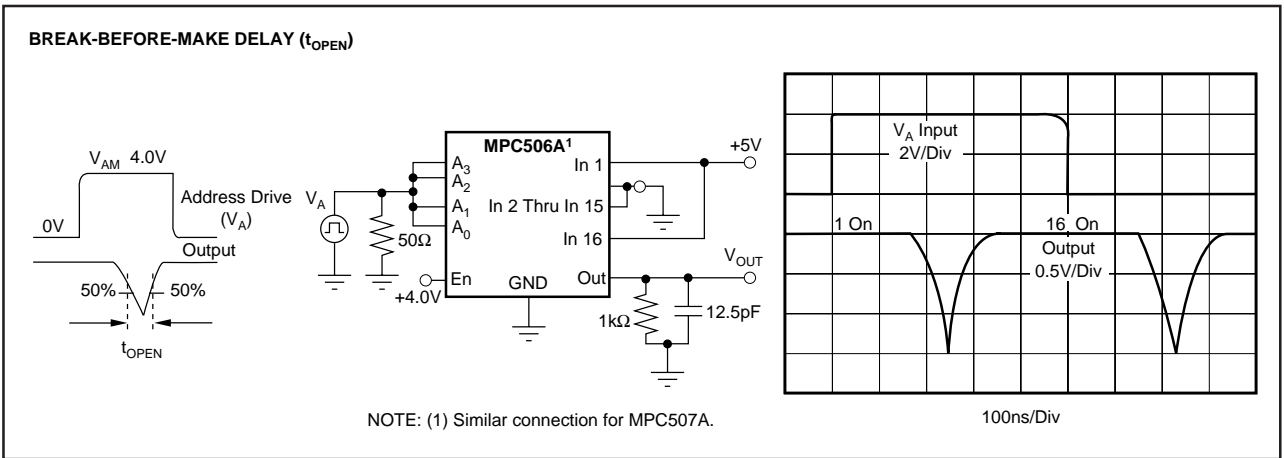

PERFORMANCE CHARACTERISTICS AND TEST CIRCUITS

$T_A = +25^\circ\text{C}$, $V_S = \pm 15\text{V}$, $V_{AM} = +4\text{V}$, $V_{AL} = 0.8\text{V}$ and $V_{REF} = \text{Open}$, unless otherwise noted.

ON RESISTANCE vs INPUT SIGNAL, SUPPLY VOLTAGE

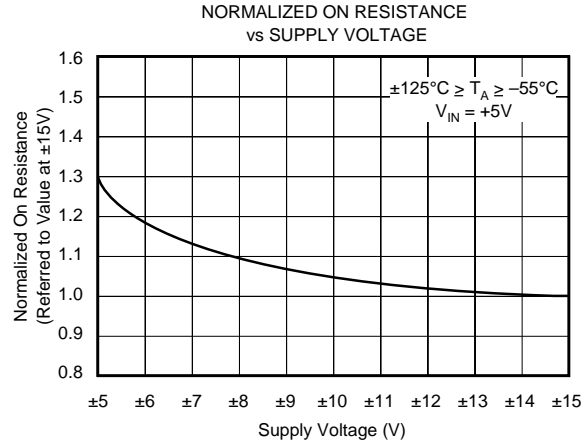
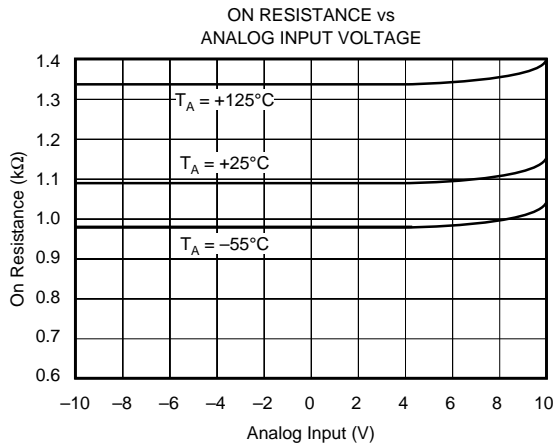
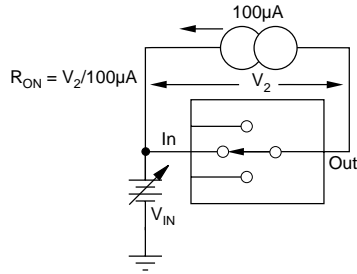

ANALOG INPUT OVERVOLTAGE CHARACTERISTICS

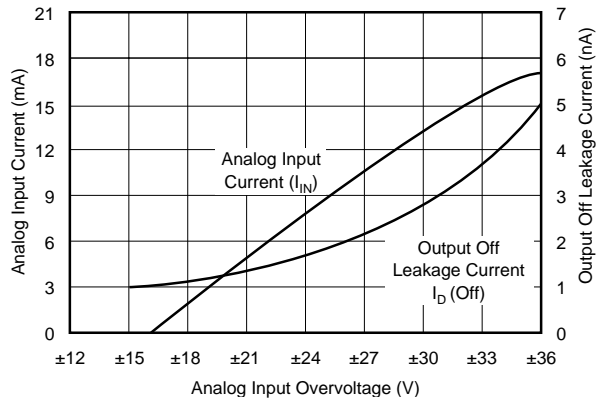
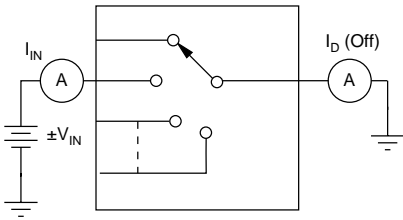

PERFORMANCE CHARACTERISTICS AND TEST CIRCUITS (CONT)

$T_A = +25^\circ\text{C}$, $V_S = \pm 15\text{V}$, $V_{AM} = +4\text{V}$, $V_{AL} = 0.8\text{V}$ and $V_{REF} = \text{Open}$, unless otherwise noted.

LEAKAGE CURRENT vs TEMPERATURE

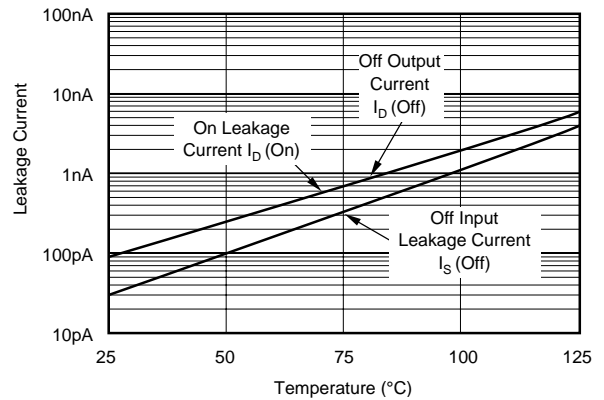
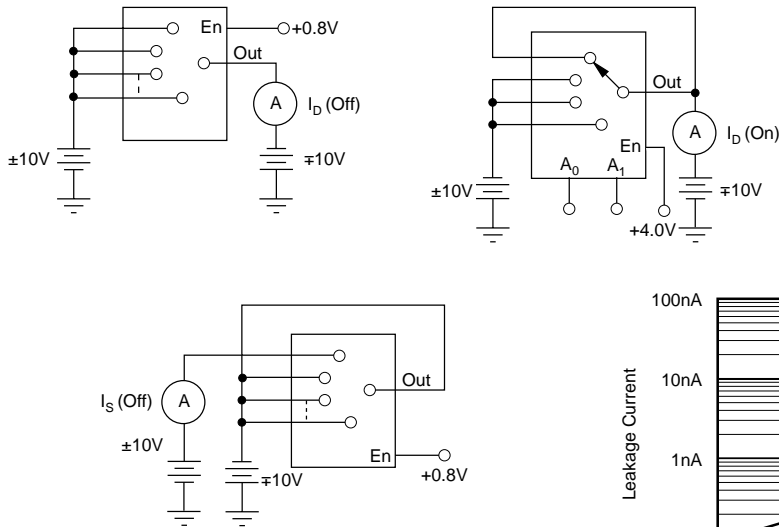

NOTE: (1) Two measurements per channel: $+10\text{V}/-10\text{V}$ and $-10\text{V}/+10\text{V}$.
(Two measurements per device for I_D (Off): $+10\text{V}/-10\text{V}$ and $-10\text{V}/+10\text{V}$).

ON-CHANNEL CURRENT vs VOLTAGE

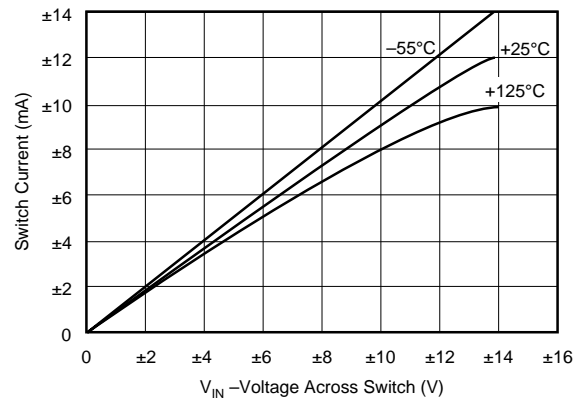
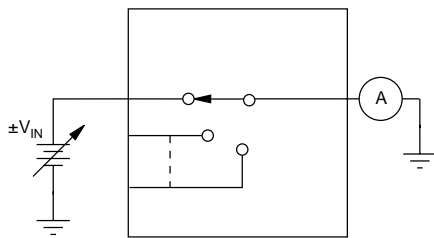

PERFORMANCE CHARACTERISTICS AND TEST CIRCUITS (CONT)

$T_A = +25^\circ\text{C}$, $V_S = \pm 15\text{V}$, $V_{AM} = +4\text{V}$, $V_{AL} = 0.8\text{V}$ and $V_{REF} = \text{Open}$, unless otherwise noted.

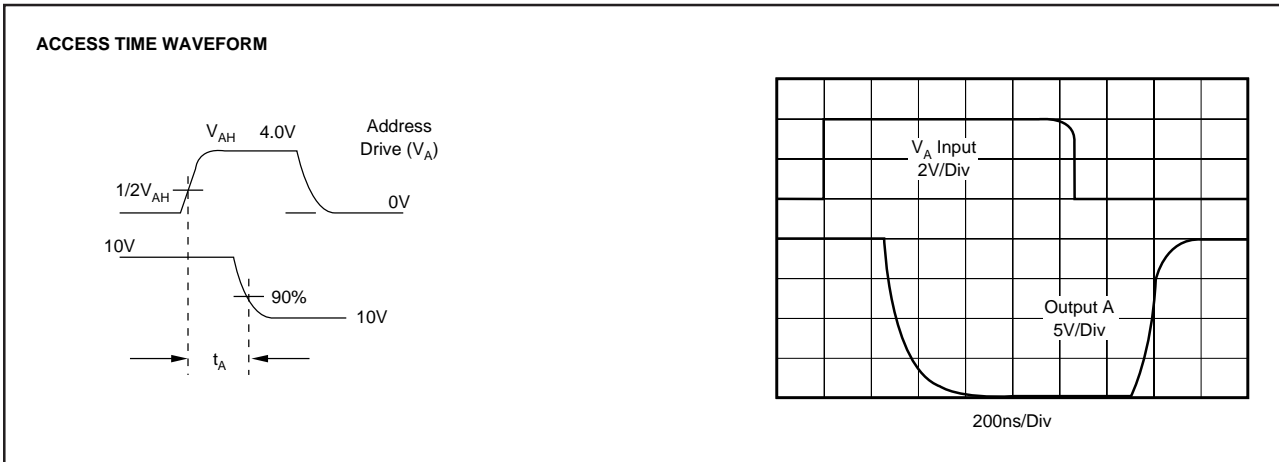
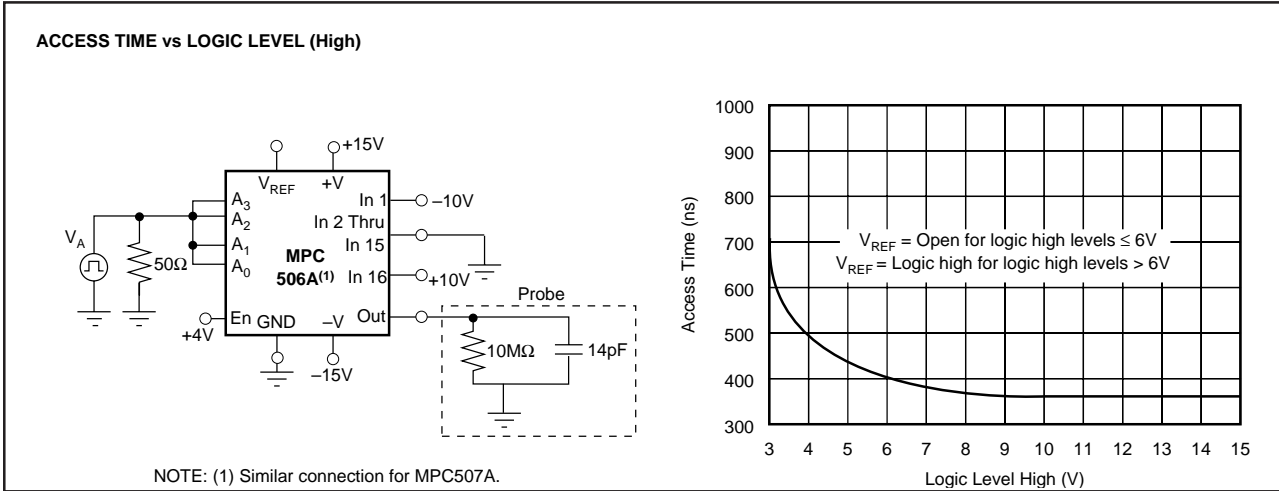
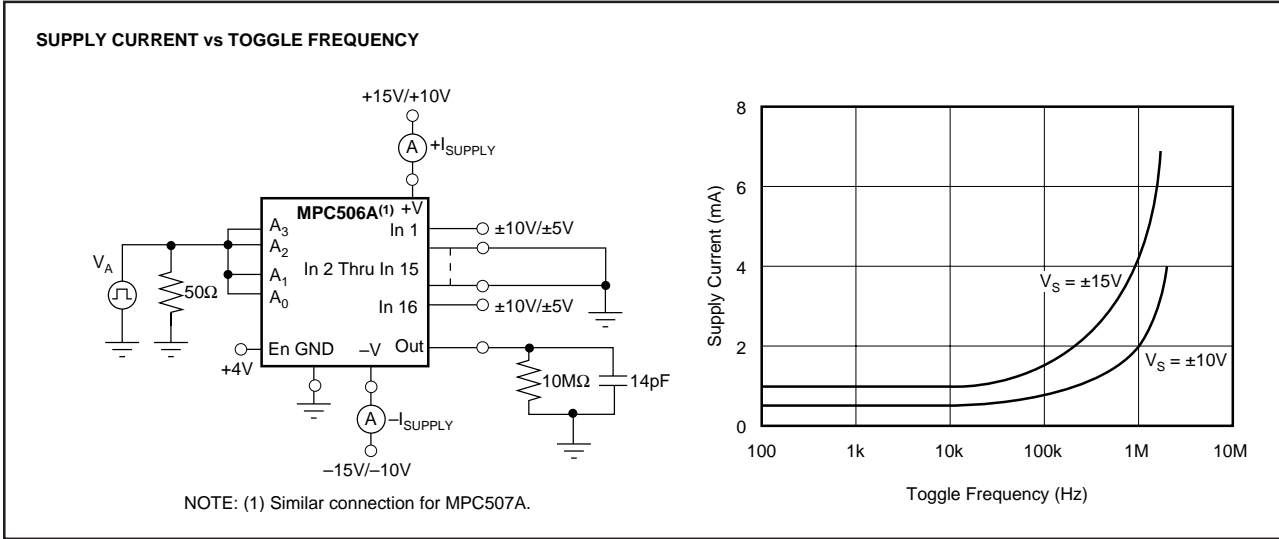

INSTALLATION AND OPERATING INSTRUCTIONS

The ENABLE input, pin 18, is included for expansion of the number of channels on a single node as illustrated in Figure 5. With ENABLE line at a logic 1, the channel is selected by the 3-bit (MPC507A or 4-bit MPC506A) Channel Select Address (shown in the Truth Tables). If ENABLE is at logic 0, all channels are turned OFF, even if the Channel Address Lines are active. If the ENABLE line is not to be used, simply tie it to +V supply.

If the +15V and/or -15V supply voltage is absent or shorted to ground, the MPC507A and MPC506A multiplexers will not be damaged; however, some signal feedthrough to the output will occur. Total package power dissipation must not be exceeded.

For best settling speed, the input wiring and interconnections between multiplexer output and driven devices should be kept as short as possible. When driving the digital inputs from TTL, open collector output with pull up resistors are recommended (see Typical Performance Curves, Access Time).

To preserve common-mode rejection of the MPC507A, use twisted-shielded pair wire for signal lines and inter-tier connections and/or multiplexer output lines. This will help common-mode capacitance balance and reduce stray signal pickup. If shields are used, all shields should be connected as close as possible to system analog common or to the common-mode guard driver.

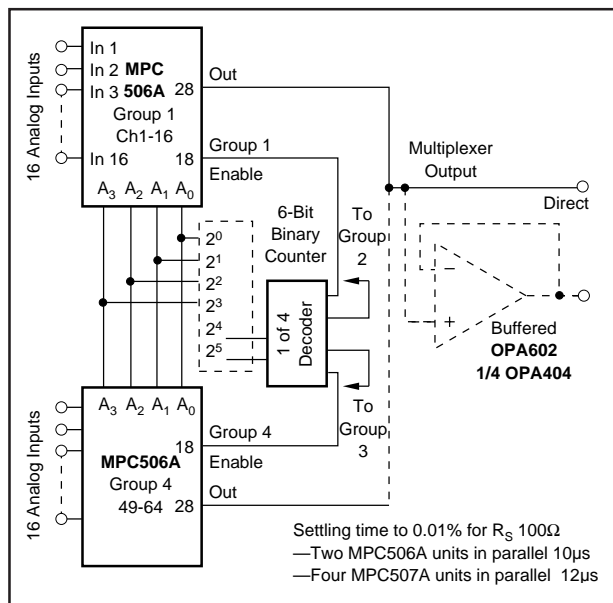

FIGURE 5. 64-Channel, Single-Tier Expansion.

CHANNEL EXPANSION

Single-Ended Multiplexer (MPC506A)

Up to 64 channels (four multiplexers) can be connected to a single node, or up to 256 channels using 17 MPC506A multiplexers on a two-tiered structure as shown in Figures 5 and 6.

Differential Multiplexer (MPC507A)

Single or multitiered configurations can be used to expand multiplexer channel capacity up to 64 channels using a 64 x 1 or an 8 x 8 configuration.

Single-Node Expansion

The 64x1 configuration is simply eight (MPC507A) units tied to a single node. Programming is accomplished with a 6-bit counter, using the 3LSBs of the counter to control Channel Address inputs A₀, A₁, A₂ and the 3MSBs of the counter to drive a 1-of-8 decoder. The 1-of-8 decoder then is used to drive the ENABLE inputs (pin 18) of the MPC507A multiplexers.

Two-Tier Expansion

Using an 8x8 two-tier structure for expansion to 64 channels, the programming is simplified. The 6-bit counter output does not require a 1-of-8 decoder. The 3LSBs of the counter drive the A₀, A₁ and A₂ inputs of the eight first-tier multiplexers and the 3MSBs of the counter are applied to the A₀, A₁, and A₂ inputs of the second-tier multiplexer.

Single vs Multitiered Channel Expansion

In addition to reducing programming complexity, two-tier configuration offers the added advantages over single-node expansion of reduced OFF channel current leakage (reduced OFFSET), better CMR, and a more reliable configuration if a channel should fail ON in the single-node configuration, data cannot be taken from any channel, whereas only one channel group is failed (8 or 16) in the multitiered configuration.

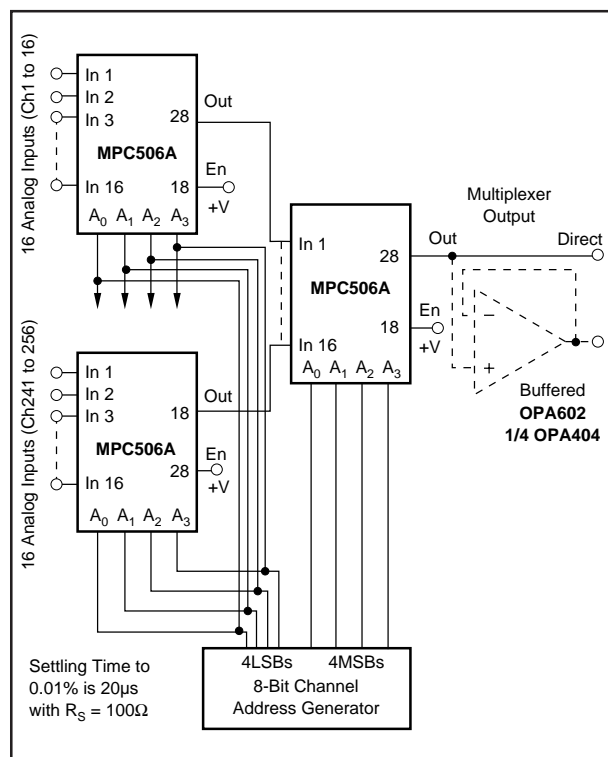

FIGURE 6. Channel Expansion up to 256 Channels Using 16x16 Two-Tiered Expansion

IMPORTANT NOTICE

Texas Instruments and its subsidiaries (TI) reserve the right to make changes to their products or to discontinue any product or service without notice, and advise customers to obtain the latest version of relevant information to verify, before placing orders, that information being relied on is current and complete. All products are sold subject to the terms and conditions of sale supplied at the time of order acknowledgment, including those pertaining to warranty, patent infringement, and limitation of liability.

TI warrants performance of its semiconductor products to the specifications applicable at the time of sale in accordance with TI's standard warranty. Testing and other quality control techniques are utilized to the extent TI deems necessary to support this warranty. Specific testing of all parameters of each device is not necessarily performed, except those mandated by government requirements.

Customers are responsible for their applications using TI components.

In order to minimize risks associated with the customer's applications, adequate design and operating safeguards must be provided by the customer to minimize inherent or procedural hazards.

TI assumes no liability for applications assistance or customer product design. TI does not warrant or represent that any license, either express or implied, is granted under any patent right, copyright, mask work right, or other intellectual property right of TI covering or relating to any combination, machine, or process in which such semiconductor products or services might be or are used. TI's publication of information regarding any third party's products or services does not constitute TI's approval, warranty or endorsement thereof.