

2.5V and 3.3V LVCMOS Clock Fanout Buffer

The MPC9446 is a 2.5V and 3.3V compatible 1:10 clock distribution buffer designed for low-voltage mid-range to high-performance telecom, networking and computing applications. Both 3.3V, 2.5V and dual supply voltages are supported for mixed-voltage applications. The MPC9446 offers 10 low-skew outputs and 2 selectable inputs for clock redundancy. The outputs are configurable and support 1:1 and 1:2 output to input frequency ratios. The MPC9446 is specified for the extended temperature range of -40°C to 85°C.

Features

- Configurable 10 outputs LVCMOS clock distribution buffer
- Compatible to single, dual and mixed 3.3V/2.5V voltage supply
- Wide range output clock frequency up to 250 MHz
- Designed for mid-range to high-performance telecom, networking and computer applications
- Supports applications requiring clock redundancy
- Max. output skew of 200 ps (150 ps within one bank)
- Selectable output configurations per output bank
- Tristable outputs
- 32 ld LQFP package
- Ambient operating temperature range of -40 to 85°C

Functional Description

The MPC9446 is a full static fanout buffer design supporting clock frequencies up to 250 MHz. The signals are generated and retimed on-chip to ensure minimal skew between the three output banks. Two independent LVCMOS compatible clock inputs are available. This feature supports redundant clock sources or the addition of a test clock into the system design. Each of the three output banks can be individually supplied by 2.5V or 3.3V supporting mixed voltage applications. The FSELx pins choose between division of the input reference frequency by one or two. The frequency divider can be set individually for each of the three output banks. The MPC9446 can be reset and the outputs are disabled by deasserting the MR/OE pin (logic high state). Asserting MR/OE will enable the outputs.

All inputs accept LVCMOS signals while the outputs provide LVCMOS compatible levels with the capability to drive terminated 50 Ω transmission lines. Please consult the MPC9456 specification for a 1:10 mixed voltage buffer with LVPECL compatible inputs. For series terminated transmission lines, each of the MPC9446 outputs can drive one or two traces giving the devices an effective fanout of 1:20. The device is packaged in a 7x7 mm² 32-lead LQFP package.

MPC9446

**LOW VOLTAGE SINGLE OR
DUAL SUPPLY 2.5V AND 3.3V
LVCMOS CLOCK
DISTRIBUTION BUFFER**

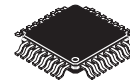

FA SUFFIX
LQFP PACKAGE
CASE 873A

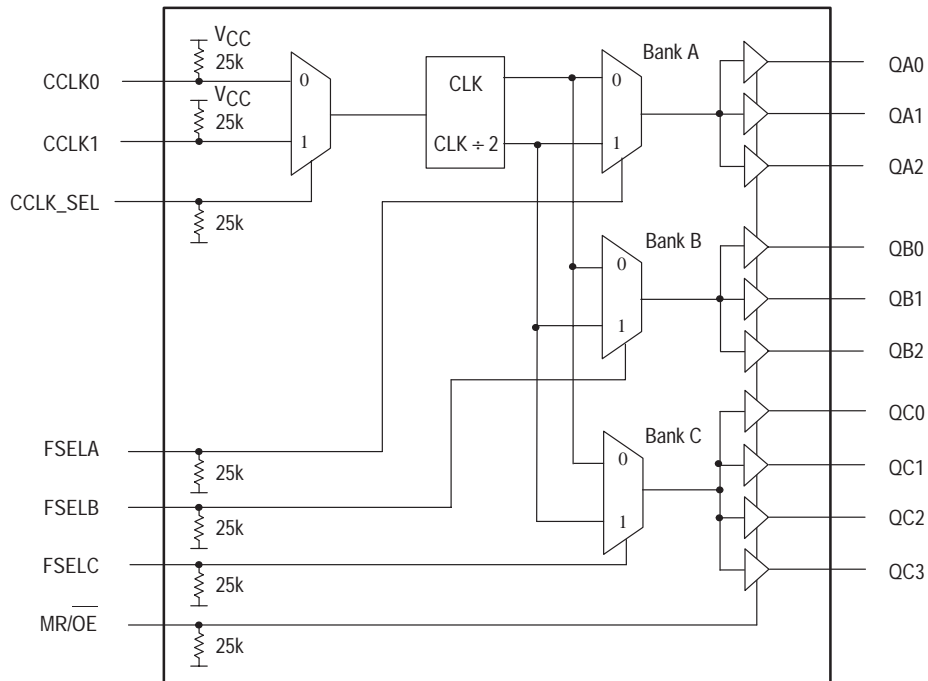

Figure 1. MPC9446 Logic Diagram

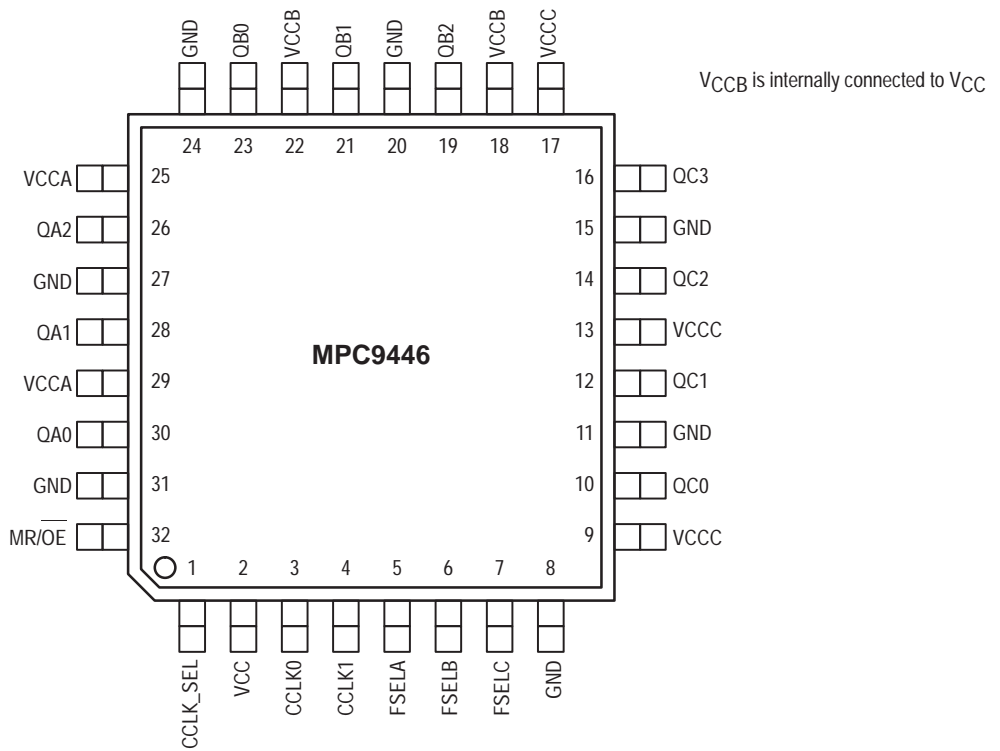

Figure 2. Pinout: 32-Lead Package Pinout (Top View)

Table 1: Pin Configuration

Pin	I/O	Type	Function
CCLK0,1	Input	LVC MOS	LVC MOS clock inputs
FSELA, FSELB, FSEL C	Input	LVC MOS	Output bank divide select input
MR/OE	Input	LVC MOS	Internal reset and output (high impedance) control
GND		Supply	Negative voltage supply (GND)
VCCA, VCCB*, VCCC		Supply	Positive voltage supply for output banks
VCC		Supply	Positive voltage supply for core (VCC)
QA0 - QA2	Output	LVC MOS	Bank A outputs
QB0 - QB2	Output	LVC MOS	Bank B outputs
QC0 - QC3	Output	LVC MOS	Bank C outputs

* VCCB is internally connected to VCC.

Table 2: Supported Single and Dual Supply Configurations

Supply voltage configuration	VCC ^a	VCCA ^b	VCCB ^c	VCCC ^d	GND
3.3V	3.3V	3.3V	3.3V	3.3V	0V
Mixed voltage supply	3.3V	3.3V or 2.5V	3.3V	3.3V or 2.5V	0 V
2.5V	2.5V	2.5V	2.5V	2.5V	0 V

- a. VCC is the positive power supply of the device core and input circuitry. VCC voltage defines the input threshold and levels
b. VCCA is the positive power supply of the bank A outputs. VCCA voltage defines bank A output levels
c. VCCB is the positive power supply of the bank B outputs. VCCB voltage defines bank B output levels. VCCB is internally connected to VCC.
d. VCCC is the positive power supply of the bank C outputs. VCCC voltage defines bank C output levels

Table 3: Function Table (Controls)

Control	Default	0	1
CCLK_SEL	0	CCLK0	CCLK1
FSELA	0	fQA0:2 = fREF	fQA0:2 = fREF + 2
FSELB	0	fQB0:2 = fREF	fQB0:2 = fREF + 2
FSEL C	0	fQC0:3 = fREF	fQC0:3 = fREF + 2
MR/OE	0	Outputs enabled	Internal reset Outputs disabled (tristate)

Table 4: Absolute Maximum Ratings^a

Symbol	Characteristics	Min	Max	Unit	Condition
VCC	Supply Voltage	-0.3	3.6	V	
VIN	DC Input Voltage	-0.3	VCC+0.3	V	
VOU T	DC Output Voltage	-0.3	VCC+0.3	V	
IIN	DC Input Current		±20	mA	
IOUT	DC Output Current		±50	mA	
TS	Storage temperature	-65	125	°C	

a. Absolute maximum continuous ratings are those maximum values beyond which damage to the device may occur. Exposure to these conditions or conditions beyond those indicated may adversely affect device reliability. Functional operation under absolute-maximum-rated conditions is not implied.

Table 5: General Specifications

Symbol	Characteristics	Min	Typ	Max	Unit	Condition
VTT	Output Termination Voltage		VCC + 2		V	
MM	ESD Protection (Machine Model)	200			V	
HBM	ESD Protection (Human Body Model)	2000			V	
LU	Latch-Up Immunity	200			mA	
CpD	Power Dissipation Capacitance		10		pF	Per output
CIN	Input Capacitance		4.0		pF	

Table 6: DC CHARACTERISTICS ($V_{CC} = V_{CCA} = V_{CCB} = V_{CCC} = 3.3V \pm 5\%$, $T_A = -40^\circ\text{C}$ to $+85^\circ\text{C}$)

Symbol	Characteristics	Min	Typ	Max	Unit	Condition
V_{IH}	Input High Voltage	2.0		$V_{CC} + 0.3$	V	LVC MOS
V_{IL}	Input Low Voltage	-0.3		0.8	V	LVC MOS
I_{IN}	Input Current ^a			200	μA	$V_{IN} = \text{GND}$ or $V_{IN} = V_{CC}$
V_{OH}	Output High Voltage	2.4			V	$I_{OH} = 24 \text{ mA}^b$
V_{OL}	Output Low Voltage			0.55 0.30	V V	$I_{OL} = 24 \text{ mA}^b$ $I_{OL} = 12 \text{ mA}$
Z _{OUT}	Output Impedance		14 - 17		Ω	
I_{CCQ}^c	Maximum Quiescent Supply Current			2.0	mA	All V_{CC} Pins

a. Input pull-up / pull-down resistors influence input current.

b. The MPC9446 is capable of driving 50Ω transmission lines on the incident edge. Each output drives one 50Ω parallel terminated transmission line to a termination voltage of V_{TT} . Alternatively, the device drives up to two 50Ω series terminated transmission lines.

c. I_{CCQ} is the DC current consumption of the device with all outputs open and the input in its default state or open.

Table 7: AC CHARACTERISTICS ($V_{CC} = V_{CCA} = V_{CCB} = V_{CCC} = 3.3V \pm 5\%$, $T_A = -40^\circ\text{C}$ to $+85^\circ\text{C}$)^a

Symbol	Characteristics	Min	Typ	Max	Unit	Condition
f_{ref}	Input Frequency	0		250 ^b	MHz	
f_{MAX}	Maximum Output Frequency	0		250 ^b	MHz	FSELx=0
	+1 output	0		125	MHz	FSELx=1
	+2 output	0				
$t_{p, REF}$	Reference Input Pulse Width	1.4			ns	
t_r, t_f	CCLK Input Rise/Fall Time			1.0 ^c	ns	0.8 to 2.0V
t_{PLH}	Propagation delay	2.2	2.8	4.45	ns	CCLK0,1 to any Q
t_{PHL}		2.2	2.8	4.2	ns	CCLK0,1 to any Q
$t_{PLZ, HZ}$	Output Disable Time			10	ns	
$t_{PZL, LZ}$	Output Enable Time			10	ns	
$t_{sk(O)}$	Output-to-output Skew			150	ps	Within one bank
	Any output bank, same output divider			200	ps	
	Any output, Any output divider			350	ps	
$t_{sk(PP)}$	Device-to-device Skew			2.25	ns	
$t_{SK(P)}$	Output pulse skew ^d			200	ps	
DC _Q	Output Duty Cycle	47	50	53	%	DC _{REF} = 50%
	+1 output	45	50	55	%	DC _{REF} = 25%-75%
	+2 output					
t_r, t_f	Output Rise/Fall Time	0.1		1.0	ns	0.55 to 2.4V

a. AC characteristics apply for parallel output termination of 50Ω to V_{TT} .

b. The MPC9446 is functional up to an input and output clock frequency of 350 MHz and is characterized up to 250 MHz.

c. Violation of the 1.0 ns maximum input rise and fall time limit will affect the device propagation delay, device-to-device skew, reference input pulse width, output duty cycle and maximum frequency specifications.

d. Output pulse skew is the absolute difference of the propagation delay times: $|t_{pLH} - t_{pHL}|$.

Table 8: DC CHARACTERISTICS ($V_{CC} = V_{CCA} = V_{CCB} = V_{CCC} = 2.5V \pm 5\%$, $T_A = -40^\circ C$ to $+85^\circ C$)

Symbol	Characteristics	Min	Typ	Max	Unit	Condition
V_{IH}	Input High Voltage	1.7		$V_{CC} + 0.3$	V	LVC MOS
V_{IL}	Input Low Voltage	-0.3		0.7	V	LVC MOS
V_{OH}	Output High Voltage	1.8			V	$I_{OH} = -15 \text{ mA}^a$
V_{OL}	Output Low Voltage			0.6	V	$I_{OL} = 15 \text{ mA}$
Z_{OUT}	Output Impedance		17 - 20 ^b		Ω	
I_{IN}	Input Current ^b			± 200	μA	$V_{IN} = \text{GND}$ or $V_{IN} = V_{CC}$
I_{CCQ}^c	Maximum Quiescent Supply Current			2.0	mA	All V_{CC} Pins

- a. The MPC9446 is capable of driving 50Ω transmission lines on the incident edge. Each output drives one 50Ω parallel terminated transmission line to a termination voltage of V_{TT} . Alternatively, the device drives up to two 50Ω series terminated transmission lines per output.
- b. Input pull-up / pull-down resistors influence input current.
- c. I_{CCQ} is the DC current consumption of the device with all outputs open and the input in its default state or open.

Table 9: AC CHARACTERISTICS ($V_{CC} = V_{CCA} = V_{CCB} = V_{CCC} = 2.5V \pm 5\%$, $T_A = -40^\circ C$ to $+85^\circ C$)^{a b}

Symbol	Characteristics	Min	Typ	Max	Unit	Condition
f_{ref}	Input Frequency	0		250 ^c	MHz	
f_{MAX}	Maximum Output Frequency	+1 output +2 output	0 0	250 ^b 125	MHz MHz	FSELx=0 FSELx=1
$t_{P, REF}$	Reference Input Pulse Width	1.4			ns	
t_r, t_f	CCLK Input Rise/Fall Time			1.0 ^d	ns	0.7 to 1.7V
t_{PLH} t_{PHL}	Propagation delay	CCLK0,1 to any Q CCLK0,1 to any Q	2.6 2.6	5.6 5.5	ns ns	
$t_{PLZ, HZ}$	Output Disable Time			10	ns	
$t_{PZL, LZ}$	Output Enable Time			10	ns	
$t_{sk(O)}$	Output-to-output Skew	Within one bank Any output bank, same output divider Any output, Any output divider		150 200 350	ps ps ps	
$t_{sk(PP)}$	Device-to-device Skew			3.0	ns	
$t_{SK(P)}$	Output pulse skew ^e			200	ps	
DCQ	Output Duty Cycle	+1 or +2 output	45	50	55	% DCREF = 50%
t_r, t_f	Output Rise/Fall Time		0.1	1.0	ns	0.6 to 1.8V

- a. AC characteristics apply for parallel output termination of 50Ω to V_{TT} .
- b. AC specifications are design targets, final specification is pending device characterization.
- c. The MPC9446 is functional up to an input and output clock frequency of 350 MHz and is characterized up to 250 MHz.
- d. Violation of the 1.0 ns maximum input rise and fall time limit will affect the device propagation delay, device-to-device skew, reference input pulse width, output duty cycle and maximum frequency specifications.
- e. Output pulse skew is the absolute difference of the propagation delay times: $|t_{pLH} - t_{pHL}|$.

Table 10: AC CHARACTERISTICS ($V_{CC} = 3.3V + 5\%$, $V_{CCA}, V_{CCB}, V_{CCC} = 2.5V + 5\%$ or $3.3V + 5\%$, $T_A = -40^\circ C$ to $+85^\circ C$)^{a b}

Symbol	Characteristics	Min	Typ	Max	Unit	Condition
$t_{sk(O)}$	Output-to-output Skew	Within one bank Any output bank, same output divider Any output, Any output divider		150 250 350	ps ps ps	
$t_{sk(PP)}$	Device-to-device Skew			2.5	ns	
$t_{PLH, HL}$	Propagation delay	CCLK0,1 to any Q	See 3.3V table			
$t_{SK(P)}$	Output pulse skew ^c			250	ps	
DCQ	Output Duty Cycle	+1 or +2 output	45	50	55	% DCREF = 50%

- a. AC characteristics apply for parallel output termination of 50Ω to V_{TT} .
- b. For all other AC specifications, refer to 2.5V or 3.3V tables according to the supply voltage of the output bank.
- c. Output pulse skew is the absolute difference of the propagation delay times: $|t_{pLH} - t_{pHL}|$.

APPLICATIONS INFORMATION

Driving Transmission Lines

The MPC9446 clock driver was designed to drive high speed signals in a terminated transmission line environment. To provide the optimum flexibility to the user the output drivers were designed to exhibit the lowest impedance possible. With an output impedance of less than 20Ω the drivers can drive either parallel or series terminated transmission lines. For more information on transmission lines the reader is referred to application note AN1091. In most high performance clock networks point-to-point distribution of signals is the method of choice. In a point-to-point scheme either series terminated or parallel terminated transmission lines can be used. The parallel technique terminates the signal at the end of the line with a 50Ω resistance to V_{CC}+2.

This technique draws a fairly high level of DC current and thus only a single terminated line can be driven by each output of the MPC9446 clock driver. For the series terminated case however there is no DC current draw, thus the outputs can drive multiple series terminated lines. Figure 3. "Single versus Dual Transmission Lines" illustrates an output driving a single series terminated line versus two series terminated lines in parallel. When taken to its extreme the fanout of the MPC9446 clock driver is effectively doubled due to its capability to drive multiple lines.

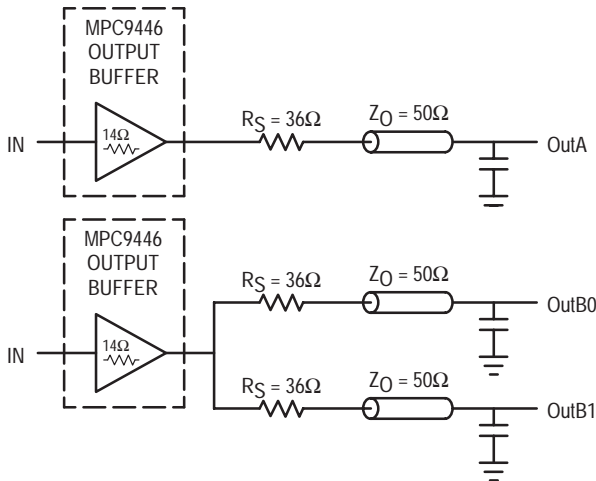

Figure 3. Single versus Dual Transmission Lines

The waveform plots in Figure 4. "Single versus Dual Line Termination Waveforms" show the simulation results of an output driving a single line versus two lines. In both cases the drive capability of the MPC9446 output buffer is more than sufficient to drive 50Ω transmission lines on the incident edge. Note from the delay measurements in the simulations a delta of only 43ps exists between the two differently loaded outputs. This suggests that the dual line driving need not be used exclusively to maintain the tight output-to-output skew of the MPC9446. The output waveform in Figure 4. "Single versus Dual Line Termination Waveforms" shows a step in the waveform, this step is caused by the impedance mismatch seen looking into the driver. The parallel combination of the 36Ω series resistor plus the output

impedance does not match the parallel combination of the line impedances. The voltage wave launched down the two lines will equal:

$$V_L = V_S (Z_0 \div (R_S + R_0 + Z_0))$$

$$Z_0 = 50\Omega \parallel 50\Omega$$

$$R_S = 36\Omega \parallel 36\Omega$$

$$R_0 = 14\Omega$$

$$V_L = 3.0 (25 \div (18+14+25))$$

$$= 1.31V$$

At the load end the voltage will double, due to the near unity reflection coefficient, to 2.5V. It will then increment towards the quiescent 3.0V in steps separated by one round trip delay (in this case 4.0ns).

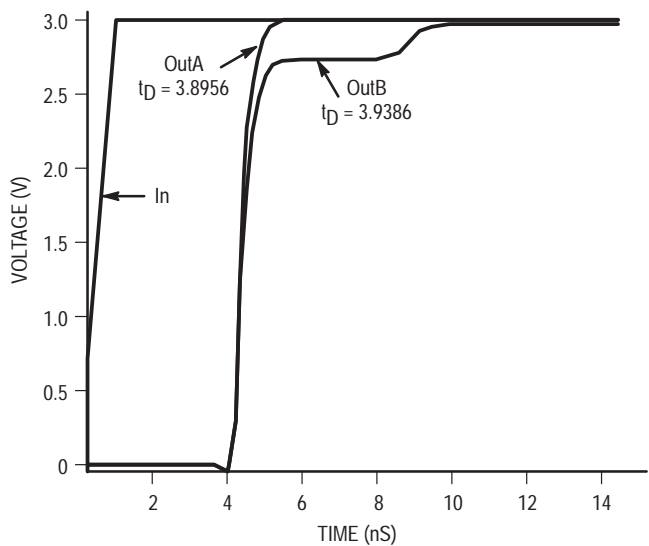

Figure 4. Single versus Dual Waveforms

Since this step is well above the threshold region it will not cause any false clock triggering, however designers may be uncomfortable with unwanted reflections on the line. To better match the impedances when driving multiple lines the situation in Figure 5. "Optimized Dual Line Termination" should be used. In this case the series terminating resistors are reduced such that when the parallel combination is added to the output buffer impedance the line impedance is perfectly matched.

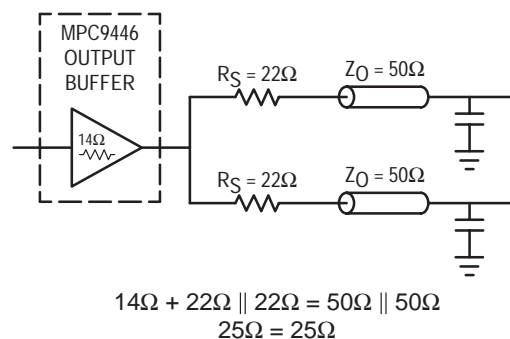

Figure 5. Optimized Dual Line Termination

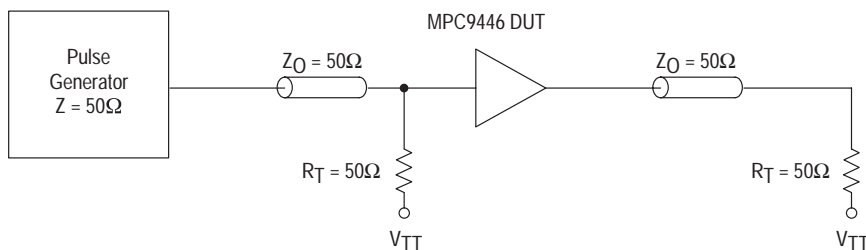

Figure 6. CCLK0,1 MPC9446 AC test reference for $V_{CC} = 3.3V$ and $V_{CC} = 2.5V$

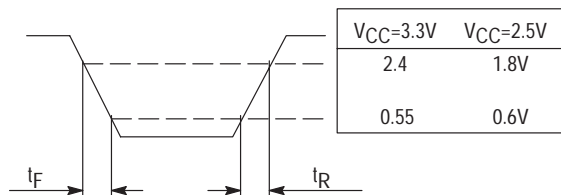

Figure 7. Output Transition Time Test Reference

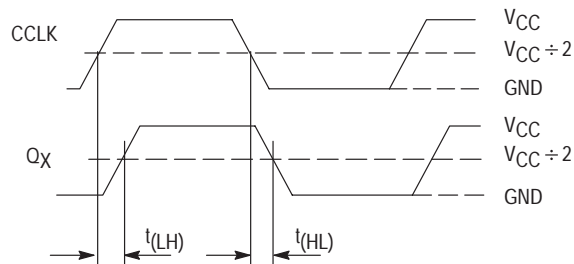
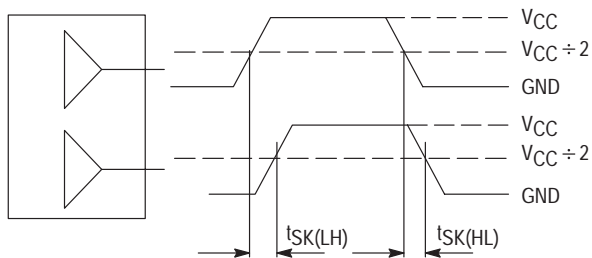
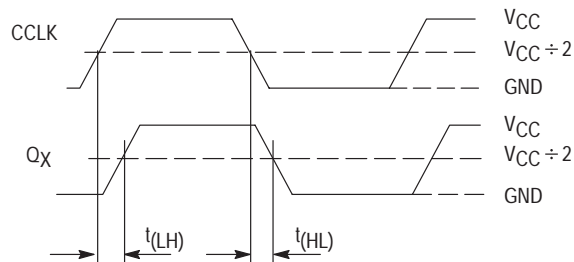

Figure 8. Propagation delay (t_{pd}) test reference



The pin-to-pin skew is defined as the worst case difference in propagation delay between any two similar delay paths within a single device

Figure 9. Output-to-output Skew $t_{SK}(LH, HL)$



$$t_{SK}(P) = |t_{PLH} - t_{PHL}|$$

Figure 10. Output Pulse Skew ($t_{SK}(P)$) test reference

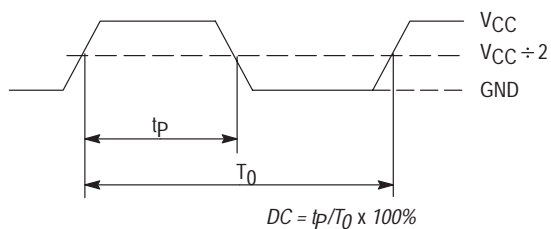

The time from the PLL controlled edge to the non controlled edge, divided by the time between PLL controlled edges, expressed as a percentage

Figure 11. Output Duty Cycle (DC)

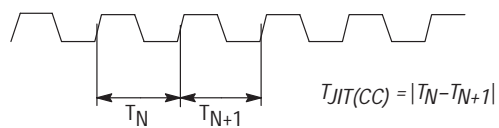

The variation in cycle time of a signal between adjacent cycles, over a random sample of adjacent cycle pairs

Figure 12. Cycle-to-cycle Jitter

OUTLINE DIMENSIONS

FA SUFFIX
LQFP PACKAGE
CASE 873A-02
ISSUE A

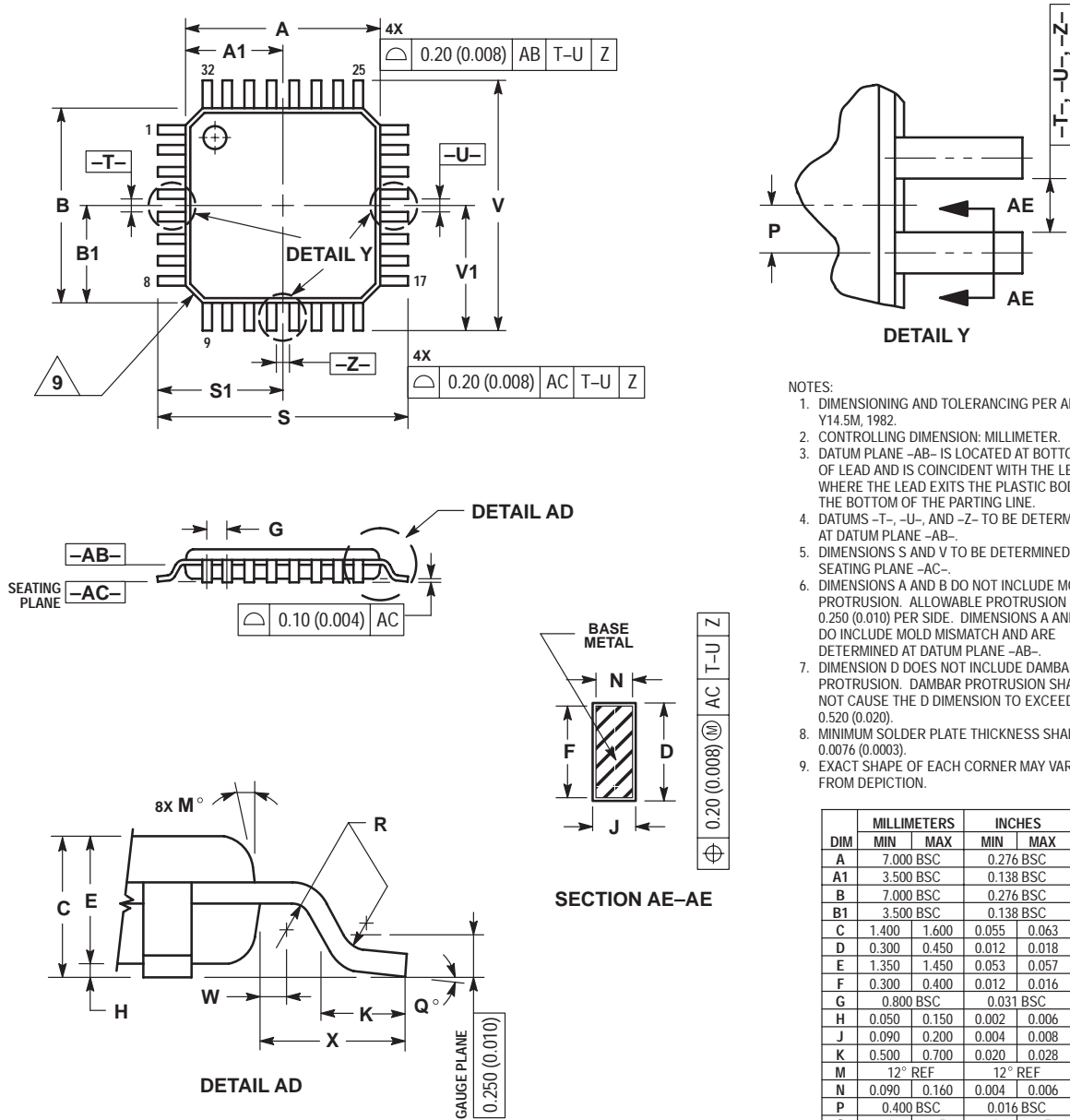

- NOTES:
1. DIMENSIONING AND TOLERANCING PER ANSI Y14.5M, 1982.
 2. CONTROLLING DIMENSION: MILLIMETER.
 3. DATUM PLANE -AB- IS LOCATED AT BOTTOM OF LEAD AND IS COINCIDENT WITH THE LEAD WHERE THE LEAD EXITS THE PLASTIC BODY AT THE BOTTOM OF THE PARTING LINE.
 4. DATUMS -T-, -U-, AND -Z- TO BE DETERMINED AT DATUM PLANE -AB-.
 5. DIMENSIONS S AND V TO BE DETERMINED AT SEATING PLANE -AC-.
 6. DIMENSIONS A AND B DO NOT INCLUDE MOLD PROTRUSION. ALLOWABLE PROTRUSION IS 0.250 (0.010) PER SIDE. DIMENSIONS A AND B DO INCLUDE MOLD MISMATCH AND ARE DETERMINED AT DATUM PLANE -AB-.
 7. DIMENSION D DOES NOT INCLUDE DAMBAR PROTRUSION. DAMBAR PROTRUSION SHALL NOT CAUSE THE D DIMENSION TO EXCEED 0.520 (0.020).
 8. MINIMUM SOLDER PLATE THICKNESS SHALL BE 0.0076 (0.0003).
 9. EXACT SHAPE OF EACH CORNER MAY VARY FROM DEPICTION.

DIM	MILLIMETERS		INCHES	
	MIN	MAX	MIN	MAX
A	7.000 BSC	0.276 BSC		
A1	3.500 BSC	0.138 BSC		
B	7.000 BSC	0.276 BSC		
B1	3.500 BSC	0.138 BSC		
C	1.400	1.600	0.055	0.063
D	0.300	0.450	0.012	0.018
E	1.350	1.450	0.053	0.057
F	0.300	0.400	0.012	0.016
G	0.800 BSC	0.031 BSC		
H	0.050	0.150	0.002	0.006
J	0.090	0.200	0.004	0.008
K	0.500	0.700	0.020	0.028
M	12° REF		12° REF	
N	0.090	0.160	0.004	0.006
P	0.400 BSC	0.016 BSC		
Q	1°	5°	1°	5°
R	0.150	0.250	0.006	0.010
S	9.000 BSC	0.354 BSC		
S1	4.500 BSC	0.177 BSC		
V	9.000 BSC	0.354 BSC		
V1	4.500 BSC	0.177 BSC		
W	0.200 REF	0.008 REF		
X	1.000 REF	0.039 REF		

NOTES

NOTES

NOTES

Motorola reserves the right to make changes without further notice to any products herein. Motorola makes no warranty, representation or guarantee regarding the suitability of its products for any particular purpose, nor does Motorola assume any liability arising out of the application or use of any product or circuit, and specifically disclaims any and all liability, including without limitation consequential or incidental damages. "Typical" parameters which may be provided in Motorola data sheets and/or specifications can and do vary in different applications and actual performance may vary over time. All operating parameters, including "Typicals" must be validated for each customer application by customer's technical experts. Motorola does not convey any license under its patent rights nor the rights of others. Motorola products are not designed, intended, or authorized for use as components in systems intended for surgical implant into the body, or other applications intended to support or sustain life, or for any other application in which the failure of the Motorola product could create a situation where personal injury or death may occur. Should Buyer purchase or use Motorola products for any such unintended or unauthorized application, Buyer shall indemnify and hold Motorola and its officers, employees, subsidiaries, affiliates, and distributors harmless against all claims, costs, damages, and expenses, and reasonable attorney fees arising out of, directly or indirectly, any claim of personal injury or death associated with such unintended or unauthorized use, even if such claim alleges that Motorola was negligent regarding the design or manufacture of the part. Motorola, Inc. Motorola, Inc. is an Equal Opportunity/Affirmative Action Employer. MOTOROLA and the  logo are registered in the US Patent & Trademark Office. All other product or service names are the property of their respective owners.

© Motorola, Inc. 2002.

How to reach us:

USA/EUROPE/Locations Not Listed: Motorola Literature Distribution; P.O. Box 5405, Denver, Colorado 80217. 1-303-675-2140 or 1-800-441-2447

JAPAN: Motorola Japan Ltd.; SPS, Technical Information Center, 3-20-1, Minami-Azabu. Minato-ku, Tokyo 106-8573 Japan. 81-3-3440-3569

ASIA/PACIFIC: Motorola Semiconductors H.K. Ltd.; Silicon Harbour Centre, 2 Dai King Street, Tai Po Industrial Estate, Tai Po, N.T., Hong Kong. 852-26668334

Technical Information Center: 1-800-521-6274

HOME PAGE: <http://www.motorola.com/semiconductors/>



MOTOROLA

