

Xtrinsic MPL3115A2 Pressure Sensor



The Smart Choice for Precise Pressure and Altitude Detection

Overview

Freescle's Xtrinsic MPL3115A2 pressure sensor provides highly precise pressure and altitude data with variable sampling rate capability up to 128 Hz. It has very low power consumption, smart features and requires zero data processing for mobile devices, medical and security applications.

The Xtrinsic MPL3115A2 pressure sensor smart features include digital output, two interrupts for auto-wake, minimum/maximum threshold detection and autonomous data acquisition. Microcontroller (MCU) usage can be limited since the MPL3115A2 pressure sensor can process sensor data locally, reducing communications required with the host processor.

The Xtrinsic MPL3115A2 pressure sensor provides unique performance that allows new user services at a low system cost. The device has extremely high accuracy—30 cm resolution (20-bit resolution measurement)—that provides a flexible output of either meters or pascals. The MPL3115A2 pressure sensor is packed with embedded functions and flexible user programmable options.

With extended battery life where the MPL3115A2 pressure sensor can run as low as 8.5 μ A at 1 Hz in low-power mode, it is ideal for mobile applications. The 32 sample FIFO can offload communications with the host processor as well as regulate the auto-wake and sleep mode functions.

Target Applications

- High-accuracy altimeter function
- High-accuracy barometer function
- Smartphones
- Tablets
- GPS dead reckoning
- Map assist/navigation
- Outdoor and indoor localization
- Personal electronics altimeter function
- Respiratory equipment
- Leisure/sports equipment
- Appliances
- Weather stations
- Security devices

MPL3115A2 Pressure Sensor

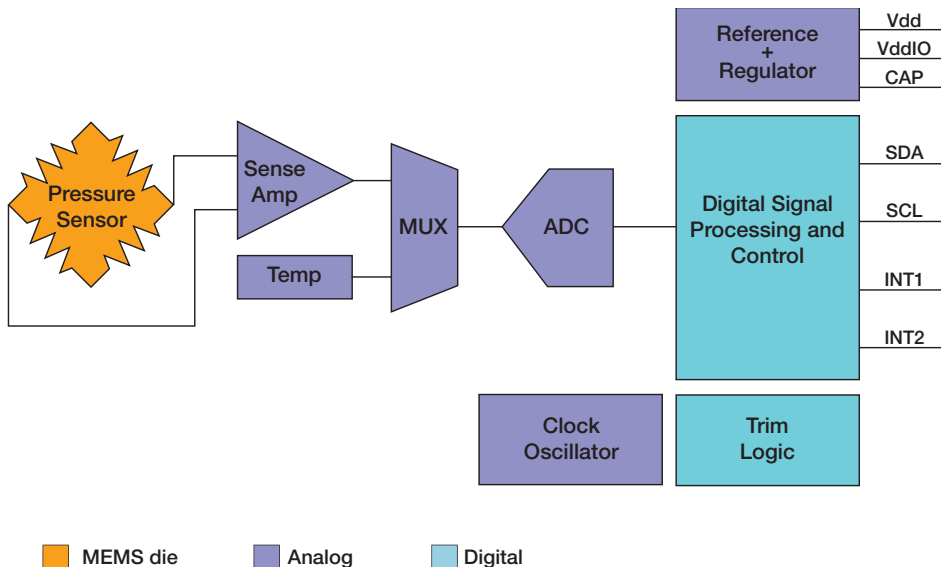

Key Features

- Altitude resolution: less than 1 foot/0.3m
- Pressure resolution: 1.5 Pa
- Compensated, direct reading (software is not needed):
 - 20-bit pressure measurement (pascals)
 - 20-bit altitude measurement (meters)
 - 12-bit temperature measurement (°Celsius)
- Onboard intelligence:
 - Interprets meters
 - Programmable events
 - Two programmable interrupt pins for auto-wake, minimum/maximum and threshold detection
 - Autonomous data acquisition
 - Embedded 32 sample FIFO buffer
- Flexible sampling rate up to 128 Hz
- I²C digital output interface (operates up to 400 kHz)
- Low current consumption:
 - Standby mode: 2 μA
 - Low-power mode: 8.5 μA at 1 Hz
- I/O interface supply: 1.6 to 3.6 V
- Supply voltage: 1.95 to 3.6 V
- Low-profile 3 x 5 x 1.1 mm LGA package

Benefits

- Highly precise pressure and altitude data
- Flexible sampling rate
- Very low power consumption
- Smart features with unique performance
- Requires zero data processing
- High accuracy—30 cm resolution (20-bit resolution measurement)
- Flexibility with output in either meters or pascals
- Easy integration and development
- Direct output of vertical height measurement saving host conversion to pressure units

Ordering Information

Part Number	Operating Supply (V)	Pressure Range (kPa)	Altitude Range (m)	Package
MPL3115A2 /T1	1.95–3.6	20–110	-656.44 (below sea level) to 12,966.31	3 x 5 x 1.1 mm LGA

Documentation

Document Number	Title	Description
MPL3115A2	MPL3115A2 Data Sheet	Presents the specifications for this product

Development Tools

Kit Number	Description
KITSTBMPL3115A2	The KITSTBMPL3115A2 contains one PCB that is the MPL3115A2 pressure sensor daughter card. Customers can purchase the LFSTBUSB communication board and the sensor interface board separately.
DEMOSTBMPL3115A2	The DEMOSTBMPL3115A2 is a complete kit containing three PCBs: the MPL3115A2 pressure sensor daughter card, the sensor interface board and the LFSTBUSB communication board for running Freescale's Sensor Toolbox PC software.

Freescale: A Leader in Sensing Solutions

Expanding on its more than 30-year heritage of sensor innovation, Freescale's Xtrinsic sensing solutions are designed with the right combination of high-performance sensing capability, processing capacity and customizable software to help deliver smart, differentiated sensing solutions. With Xtrinsic sensors, our vision is to offer a diverse and differentiated product portfolio to meet the expanding needs of the automotive, consumer and industrial segments. Xtrinsic solutions offer ideal blends of functionality and intelligence designed to help our customers differentiate and win in highly competitive markets.

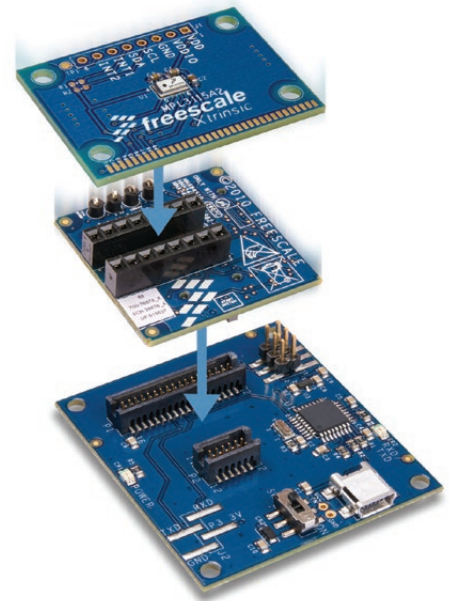

The DEMOSTBMPL3115A2 development kit