

MSC8122ADS

MSC8122 Application Development System

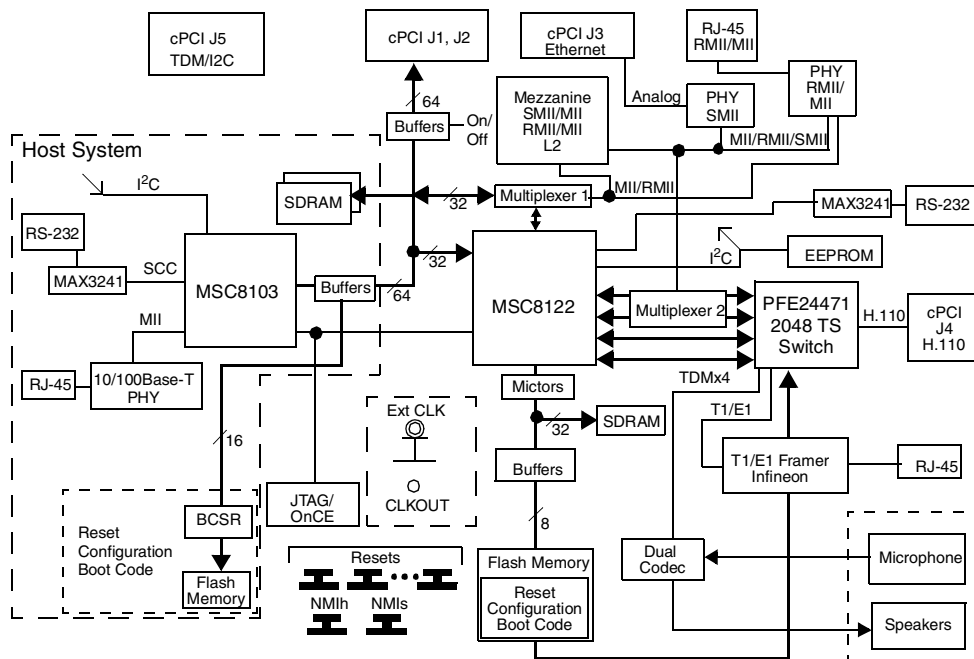

Figure 1. MSC8122ADS Block Diagram

Use this board as a reference design to start your MSC8122 projects immediately, instead of developing and assembling custom hardware. Accelerate product development and testing to shorten time to market.

The MSC8122ADS board uses the Freescale MSC8122 processor, a highly integrated system-on-a-chip device containing four StarCore™ SC140 DSP cores along with an MSC8103 device as the host processor. Both devices use a similar system interface unit (SIU). The MSC8122ADS board serves as a platform for software and hardware development in the MSC8122 processor environment. Developers can use the on-board resources and the associated debugger to perform a variety of tasks, such as downloading and running code, setting breakpoints, displaying memory and registers, and connecting proprietary hardware via the expansion connectors. The board works seamlessly with the CodeWarrior® Development Studio for StarCore.

The MSC8122 targets high-bandwidth highly computational DSP applications and is optimized for wireless transcoding and packet telephony as well as high-bandwidth base station applications. The MSC8122 delivers enhanced performance while maintaining low power dissipation and greatly reducing system cost.

Features

Feature	Description
Board Specifications	<ul style="list-style-type: none"> • Operating temperature: 0 to 30° C (room temperature). • Storage temperature: -25 to 85° C. • Dimensions: 233.35 mm × 160.0 mm × 1.8 mm. • CS height: 17 mm. • PS height 1.9 mm. • 9–18 V external DC power supply. For a 12 V supply, maximum current 1.8 A.
MSC8122	<ul style="list-style-type: none"> • Four-core DSP with internal clock up to 500 MHz at 1.2 V. • System bus frequency up to 166 MHz using 64 or 32 data lines, addressing up to 4 GB external memory, connected to: <ul style="list-style-type: none"> — 16 MB of soldered, non-buffered on one 4-bank × 1 M × 32-bit device. — 4 MB of buffered Flash memory organized as 4 M × 8-bit for configuration/boot/program storage. • DSI frequency up to 100 MHz as a 32-bit or 64-bit slave on the MSC8103 system bus connects to: <ul style="list-style-type: none"> — 2 MB of non-buffered SDRAM organized as 32-bit (default) or 64-bit. — 16 MB of 100 MHz soldered, non-buffered SDRAM, organized on two 4-bank × 32-bit devices. — 4 MB of 16-bit buffered Flash memory. • Buffered board control and status register (BCSR) with eight byte-sized registers. • SDRAM machine controls the SDRAM on the system bus. • Four MSC8122 TDM ports connect to the Infineon TSI PEF24471 device. • Interconnection of T1/E1 timeslots between the Infineon FALC PEB2256 and the Dual CODEC MT92303. • TDM bus has optional connection to J4 cPCI connector. • RS-232 Transceiver MAX3241 supports the UART port operation of the MSC8122. • SMI1 support for MAC-to-PHY or MAC-to-MAC connections. • RMI1 and MI1 support for MAC-to-PHY connections. • Core power level adjustable via potentiometer.
MSC8103	<ul style="list-style-type: none"> • Single-core DSP with internal clock up to 300 MHz. • System bus frequency up to 100 MHz. • 32 address lines and 64 data lines to address up to 4 GB of external memory. • Buffered connection to slave cPCI bus. • SDRAM machine controls system bus SDRAM. • 4 MB of 16-bit Flash memory for configuration/boot/program storage. • CPM ports to connect to 10/100Base-T controller and RS-232 transceiver. • 8-bit BCSR for ADS configuration.
MSC8122ADS	<ul style="list-style-type: none"> • Host debug through a single JTAG connector supports both the MSC8103 and MSC8122 processors. • MSC8103 is the MSC8122 host. The MSC8103 system bus connects to the MSC8122 DSI. • Flash memory for stand-alone applications. • Communications ports: <ul style="list-style-type: none"> — 10/100Base-T. — 155 Mbit ATM over Optical. — T1/E1 TDM interface. — H.110. — Voice codec. — RS-232. — High-density (MICTOR) logic analyzer connectors to monitor MSC8122 signals. — 6U CompactPCI form factor. • Emulates MSC8122 DSP farm by connecting to three other ADS boards. • Allows MAC-to-MAC connection between the MSC8122 and the MSC8103. • Programmable hard reset configuration for MSC8122 from Flash memory, the DSI, or forced from the BCSR. • MSC8122 boots from Flash memory on the system bus, UART, or TDM ports. • High density (MICTOR) logic analyzer connectors for MSC8122 signal measurement or external board connection. • As expansion connectors, CompactPCI® connectors carry MSC8122 signals to off-board tools to enable chip verification and evaluation. • MAX4372 current-sense amplifier for current measurement of MSC8122 PLL/IO/core power. • Debugging via an external command converter connected to the EOnCE 14-pin headers or parallel port connected to the cPCI J3 connector. • EOnCE debug chain to connect additional ADS boards via the backplane.

Feature	Description
MSC8122ADS (continued)	<ul style="list-style-type: none"> • After reset, selectable Debug Enable/Disable and Debug Request options. • Board identification and board status read via the BCSR. • Connection of external pulse generator to MSC8122 clock input via SMB-form RF connectors. • Variant board configurations available via the Dual-In-Line Package (DIP) Switch setting. • Push buttons for both the host and slave: power-on reset, soft reset, hard reset, and abort. • Voltage to the board via two DC-DC converters, one with 3.3 V at 16 A and the second with 0.9–2.0 V at 16 A. The first supplies 3.3 V I/O and the 1.6 V core voltage for the MSC8103. The second supplies the MSC8122 core voltage. • SLIC-SLAC interface enables use of 6-line communication board with Voice-over-Broadband SLIC/SLAC chip set. • Software option switch provides 8 software options via the BCSR. • LEDs indicate power supply, peripheral enables, EE1 pin status, and software signals.

Product Documentation

Table 1 lists the documentation that supports the MSC8122ADS. Documentation is available from a local Freescale distributor, a Freescale semiconductor sales office, or a Freescale Literature Distribution Center. For documentation updates, visit the Freescale DSP website.

Table 1. MSC8122ADS Documentation

Name	Description	Order Number
<i>MSC8122 Technical Data</i>	MSC8122 features list and physical, electrical, timing, and package specifications	MSC8122
<i>MSC8122 Reference Manual</i>	Detailed functional description of the MSC8122 memory and peripheral configuration, operation, and register programming	MSC8122RM
<i>StarCore™ SC140 DSP Core Reference Manual</i>	Detailed description of the SC140 family processor core and instruction set	MNSC140CORE/D
<i>MSC8103 Technical Data</i>	MSC8103 features list and physical, electrical, timing, and package specifications	MSC8103
<i>MSC8103 Reference Manual</i>	Detailed functional description of the MSC8103 memory and peripheral configuration, operation, and register programming	MSC8103RM
<i>MSC8122ADS/ MSC8126ADS Reference Manual</i>	Detailed functional description of the MSC8122ADS and MSC8126ADS boards including memory and peripheral configuration, switch settings, operation, connections, and programming	MSC8122ADSRM
<i>Application Notes</i>	Documents describing specific applications or optimized device operation including code examples	Refer to the MSC8122 and MSC8103 product pages.

How to Reach Us:

Home Page:
www.freescale.com

E-mail:
support@freescale.com

USA/Europe or Locations not listed:
Freescale Semiconductor
Technical Information Center, CH370
1300 N. Alma School Road
Chandler, Arizona 85224
+1-800-521-6274 or +1-480-768-2130
support@freescale.com

Europe, Middle East, and Africa:
Freescale Halbleiter Deutschland GMBH
Technical Information Center
Schatzbogen 7
81829 München, Germany
+44 1296 380 456 (English)
+46 8 52200080 (English)
+49 89 92103 559 (German)
+33 1 69 35 48 48 (French)
support@freescale.com

Japan:
Freescale Semiconductor Japan Ltd.
Headquarters
ARCO Tower 15F
1-8-1, Shimo-Meguro, Meguro-ku,
Tokyo 153-0064, Japan
0120 191014 or +81 3 5437 9125
support.japan@freescale.com

Asia/Pacific:
Freescale Semiconductor Hong Kong Ltd.
Technical Information Center
2 Dai King Street
Tai Po Industrial Estate
Tai Po, N.T. Hong Kong
+800 2666 8080
support.asia@freescale.com

For Literature Requests Only:
Freescale Semiconductor Literature Distribution Center
P.O. Box 5405
Denver, Colorado 80217
1-800-441-2447 or 303-675-2140
Fax: 303-675-2150
MSC8122ADSPB
Rev. 0
1/2005

Information in this document is provided solely to enable system and software implementers to use Freescale Semiconductor products. There are no express or implied copyright licenses granted hereunder to design or fabricate any integrated circuits or integrated circuits based on the information in this document.

Freescale Semiconductor reserves the right to make changes without further notice to any products herein. Freescale Semiconductor makes no warranty, representation or guarantee regarding the suitability of its products for any particular purpose, nor does Freescale Semiconductor assume any liability arising out of the application or use of any product or circuit, and specifically disclaims any and all liability, including without limitation consequential or incidental damages. "Typical" parameters which may be provided in Freescale Semiconductor data sheets and/or specifications can and do vary in different applications and actual performance may vary over time. All operating parameters, including "Typicals" must be validated for each customer application by customer's technical experts. Freescale Semiconductor does not convey any license under its patent rights nor the rights of others. Freescale Semiconductor products are not designed, intended, or authorized for use as components in systems intended for surgical implant into the body, or other applications intended to support or sustain life, or for any other application in which the failure of the Freescale Semiconductor product could create a situation where personal injury or death may occur. Should Buyer purchase or use Freescale Semiconductor products for any such unintended or unauthorized application, Buyer shall indemnify and hold Freescale Semiconductor and its officers, employees, subsidiaries, affiliates, and distributors harmless against all claims, costs, damages, and expenses, and reasonable attorney fees arising out of, directly or indirectly, any claim of personal injury or death associated with such unintended or unauthorized use, even if such claim alleges that Freescale Semiconductor was negligent regarding the design or manufacture of the part.

Freescale™ and the Freescale logo are trademarks of Freescale Semiconductor, Inc. StarCore is a trademark of StarCore LLC. Metrowerks and CodeWarrior are registered trademarks of Metrowerks Corp. in the U.S. and/or other countries. All other product or service names are the property of their respective owners.

© Freescale Semiconductor, Inc. 2005.

