Short Information

MSP 3402C

Sound Processor for Korea

(68-Pin PLCC Package, 64-pin PSDIP Package, or 52-pin PSDIP Package)

The MSP 3402C is designed as a single-chip sound processor for applications in analog and digital TV sets, satellite receivers, video recorders, and PC-cards for Korea.

The MSP 3402C increases function integration in a spectacular way. The chips are produced in submicron CMOS technology and will offer a wide range of interesting features combined with high performance digital signal processing. The complete TV-sound-processing, starting at the Sound-IF domain, will be performed by one single IC.

The IC's input signal consists of analog audio signals in baseband and at intercarrier position. The MSP 3402C covers the sound processing of the TV-standard M.

The MSP 3402C is fully backwards compatible to the MSP 3410B/D, which include NICAM sound decoding.

The MSP 3402C offers the following advantages:

- two selectable analog inputs
- Automatic Gain Control (AGC) for analog input: input range: 0.14 – 3 Vpp
- Sound-IF frequency 4.5 MHz and 4.7242 MHz
- integrated A/D converter
- all demodulation and filtering is performed on chip and is individually programmable
- no external filter hardware is required
- only one crystal clock (18.432 MHz) is necessary
- FM carrier mute function
- flexible selection of audio sources
- digital input and output interfaces via S-Bus for D2MAC, and via I²S-Bus for external DSP-Processors featuring Surround Sound etc.
- digitally performed FM-identification decoding and dematrixing for Korea 2-tone system
- digital baseband processing: volume, bass/treble or 5 band graphic equalizer, pseudostereo and base-width enlargement
- simplified controlling of volume, bass, treble etc.
- increased audio bandwidth for FM-Audio-signals (20 Hz – 15 kHz, ±1 dB)

MSP 3402C

Short Information

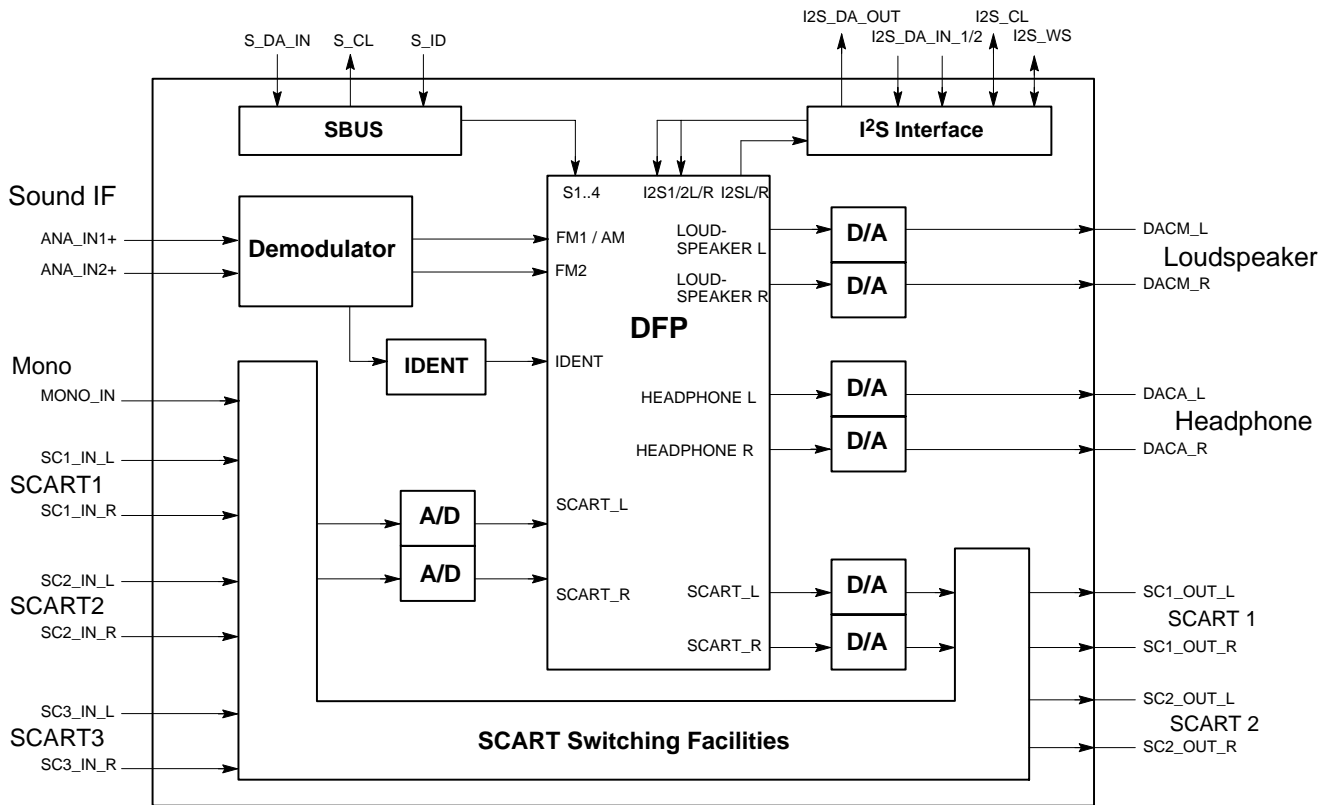

Architecture of the MSP 3402C

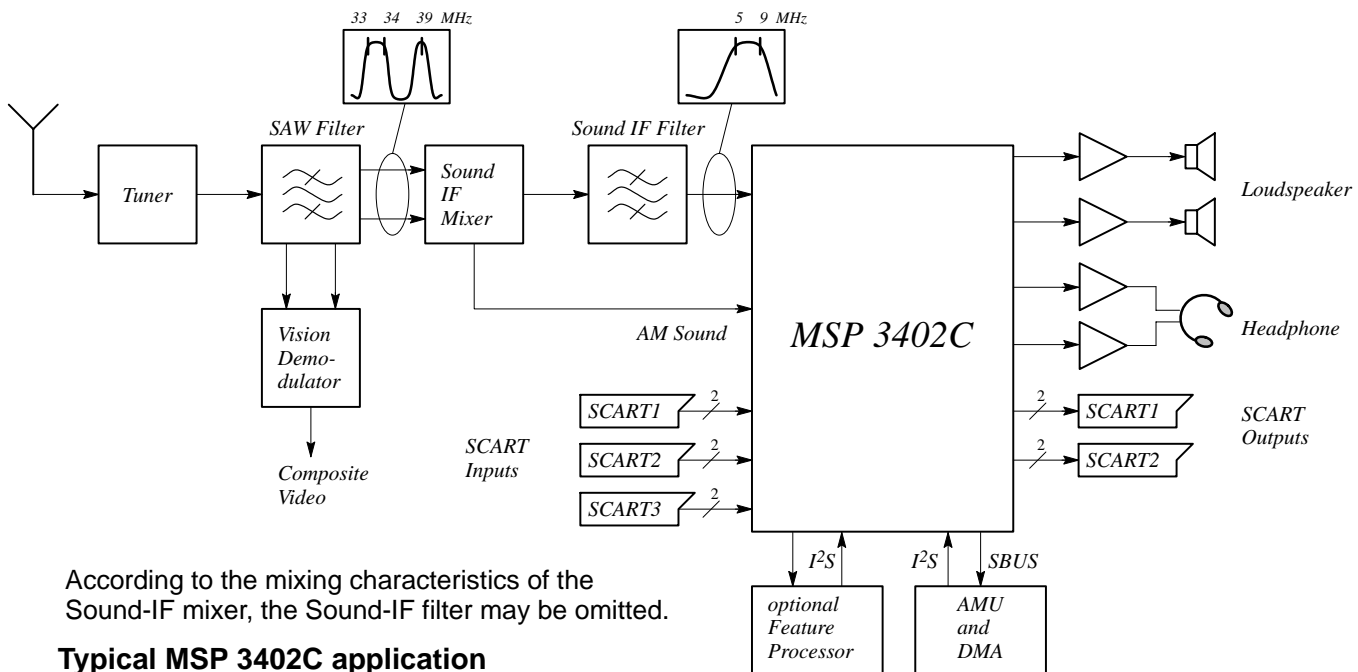

According to the mixing characteristics of the Sound-IF mixer, the Sound-IF filter may be omitted.

Typical MSP 3402C application

MICRONAS INTERMETALL GmbH
 Hans-Bunte-Strasse 19
 D-79108 Freiburg (Germany)
 P.O. Box 840
 D-79008 Freiburg (Germany)
 Tel. +49-761-517-0
 Fax +49-761-517-2174
 E-mail: docservice@intermetall.de
 Internet: http://www.intermetall.de

All information in this short information is without any commitment, is not to be considered as an offer for conclusion of a contract nor shall it be construed as to create any liability. Product availability and delivery dates are exclusively subject to our order confirmation. By this publication, MICRONAS INTERMETALL GmbH does not assume responsibility for infringements of patents or other rights of third parties, which may result from its use or the use of the product. Our prior written consent must be obtained for reprinting.

Edition: Sept. 13, 1996
 Order No. 6251-426-1SI