

TENTATIVETOSHIBA BIPOLAR LINEAR INTEGRATED CIRCUIT
SILICON MONOLITHIC

TA1298BN

PAL / NTSC VIDEO, CHROMA, AND DEFLECTION IC FOR COLOR TV (NORMAL SCAN / DOUBLE SCAN MODE)

TA1298BN is a signal processor IC for PAL / NTSC color TV, integrating video, chroma, sync / deflection (sync processing only in Double Scan mode) processors in a 56-pin shrink dual-in-line plastic package. It is suitable for high-quality, large-screen, wide, and double-scanning TV.

The video section has a high-performance sharpness correction circuit (for YUV double scanning). The chroma section has a PAL / NTSC auto detector circuit. The sync / deflection section has a 50 / 60 Hz auto detector circuit. The PAL demodulator circuit includes a baseband signal processor, making the circuit adjustment free. TA1298BN incorporates an I²C bus, enabling the user to set controls and functions via the bus.

FEATURES

Video and chroma sections

- Y delay line
- Chroma trap
- IQ demodulation for NTSC ; UV demodulation for PAL
- Color decoder tint

Back-end processor (BEP) section (Y processing / color difference processing / text sections)

- Independent operation from video and chroma demodulators
- Double scanning signal processing (Y processing section)
 - Black stretcher (controlled by I²C bus)
 - Variable DC restoration rate (controlled by I²C bus)
 - High bright color
 - Delay aperture sharpness circuit (APACON) + luminance transient improver (LTI)
 - γ correction (one-point break line, gain, and start point controllable)
 - Y noise reduction circuit
 - Speed modulation output (first-order differential output, phase / amplitude adjustable)

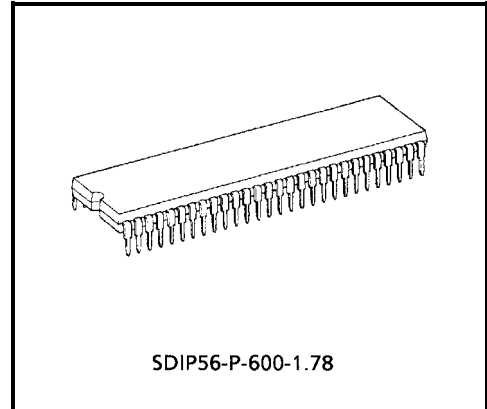

Weight: 5.55g (Typ.)

(Color difference processing section)

- Color detail enhancer
- Relative phase and amplitude switchable
- Flesh-color correction (only at IQ modulation)
- Color γ
- Baseband tint control

(Text section)

- Primary color output
- On-screen-display (OSD) interface
- Linear RGB interface
- Drive control

Sync / deflection section

- High-performance sync separator circuit
- Adjustment-free horizontal and vertical oscillator circuits by countdown
- Horizontal and vertical position adjustment
- Sync separation, horizontal / vertical output
- Horizontal / vertical pulse output (in Normal Scan mode only)

BLOCK DIAGRAM

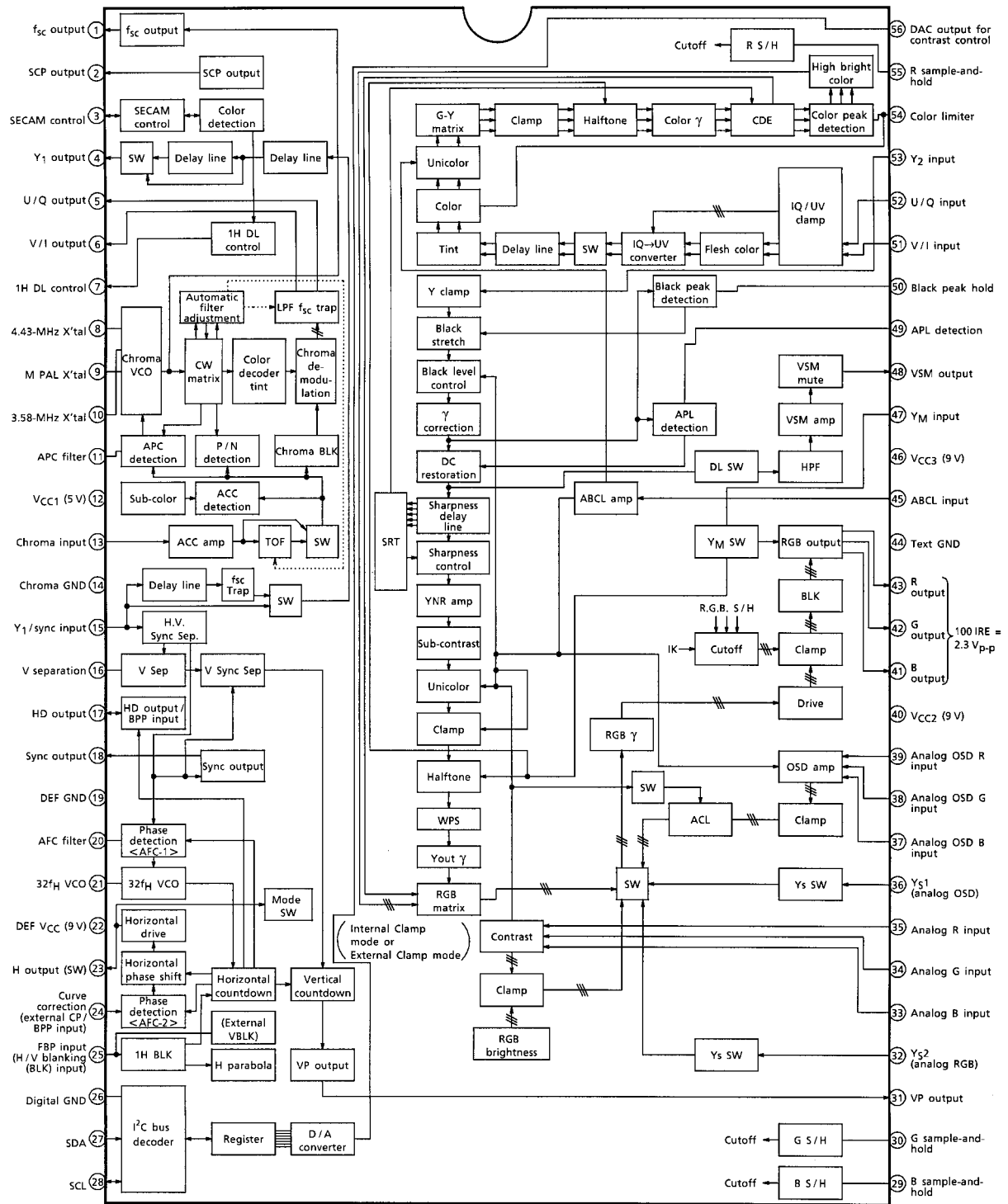

- Connecting pin 23 to VCC enters Double Scan mode (External Clamp Pulse input mode).

Note: Enclosed in square brackets is in Double Scan mode only.

PIN FUNCTIONS



PIN NO.	PIN NAME	FUNCTION	INTERFACE	INPUT / OUTPUT SIGNAL
1	f_{sc} output	<p>Outputs VCXO oscillation waveform.</p> <p>When 3.58-MHz NTSC signal is input and data are color, output DC is 3.2 V.</p> <p>When black & white (B&W) or any other signal is input, output DC is 1.4 V.</p>		<p>DC</p> <p>3.58-MHz NTSC signal, in color : 3.2 V</p> <p>B&W, other than NTSC : 1.4 V</p> <p>AC</p> <p>0.6 V_{p-p}</p>
2	SCP output	<p>Outputs sand castle pulse (SCP).</p> <p>Output signals consist of clamp pulses, horizontal blanking pulses, vertical blanking pulses.</p> <p>The minimum load resistance is 3 kΩ.</p>		
3	SECAM control	<p>I / O pin used to control SECAM demodulator IC.</p> <p>When current flow from this pin is 250 μA or more, SECAM is identified.</p>		<p>For PAL / NTSC : 4.0 V</p> <p>For SECAM : 0.75 V</p>
4	Y ₁ output	<p>Outputs Y signal through the f_{sc} trap (trap is turned on / off by bus) and the Y delay line circuit.</p>		
5	U / Q output	<p>Outputs B-Y (U) or Q signal.</p> <p>LPF used to remove carrier is incorporated.</p>		<p>DC</p> <p>2.5 V</p> <p>Rainbow color bar : 360 mV_{p-p}</p>

PIN NO.	PIN NAME	FUNCTION	INTERFACE	INPUT /OUTPUT SIGNAL
6	V / I output	<p>Outputs R-Y (V) or I signal.</p> <p>LPF used to remove carrier is incorporated.</p> <p>Chroma signal after passing through ACC and TOF circuits (before input to demodulator) can be monitored by pulling up the pin at 10 kΩ.</p>		<p>DC 2.5 V</p> <p>Rainbow color bar : 360 mV_{p-p}</p>
7	1H DL control	<p>Outputs the result of signal identification : PAL, SECAM, or NTSC. Connect the output to 1H DL IC.</p> <p>For B&W identification, the voltage immediately beforehand is held.</p> <p>The voltage immediately after power on is undefined.</p>		<p>8.4 V : PAL 4.3 V : SECAM 0 V : NTSC</p>
8	4.43-MHz X'tal	<p>Connect X'tal. With series capacitance, oscillation frequency (f₀) can be varied ; with parallel capacitance, frequency range can be varied.</p>		<p>DC 4.0 V 90 mV_{p-p}</p>
9	M PAL X'tal			
10	3.58-MHz X'tal			
11	APC filter	<p>Connect APC filter for chroma demodulation.</p> <p>The pin voltage determines the VCXO frequency.</p>		<p>DC</p>
12	V _{CC1} (5 V)	<p>V_{CC} for chroma and I²C bus blocks.</p> <p>Connect 5 V (typ.).</p>	<p>—</p>	<p>—</p>

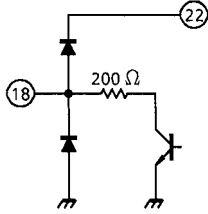
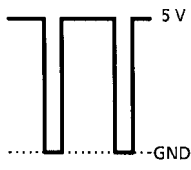
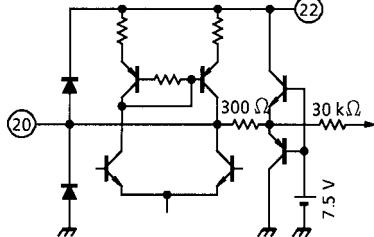
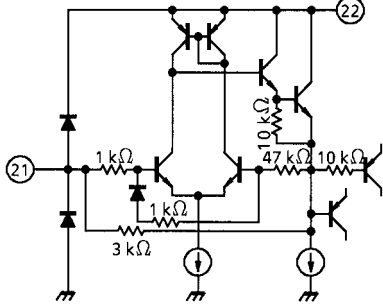
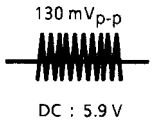
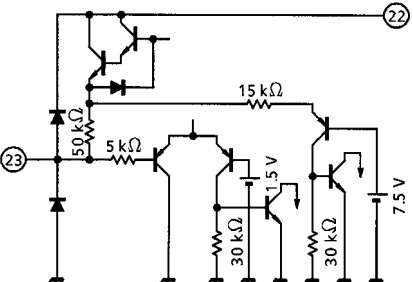
PIN NO.	PIN NAME	FUNCTION	INTERFACE	INPUT / OUTPUT SIGNAL
13	Chroma input	Chroma input pin. Input chroma signal after Y / C separation.		
14	Chroma GND	GND pin for chroma processing block.	—	—
15	Y ₁ / sync input	Inputs composite video or Y signal. Input via clamp capacitor.		
16	V separation	Connect filter used to separate vertical sync signal.		DC 6.4 V
17	HD output	<p>(1) When bus HD-OUT = 0, outputs HD pulse (duration : 1 μs) on which AFC is performed. Also used as an external input pin for BPP (black peak detection stopping pulse) signal.</p> <p>(2) When bus HD-OUT = 1 and AKB = ON, outputs pulse which covers the AKB reference period.</p>		

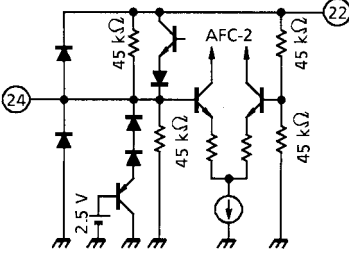
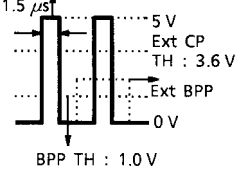
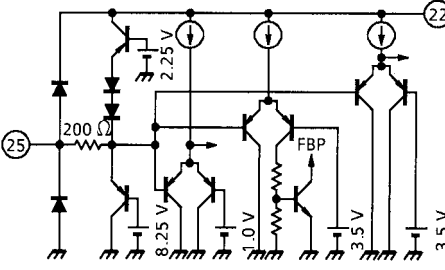
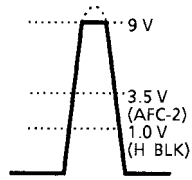
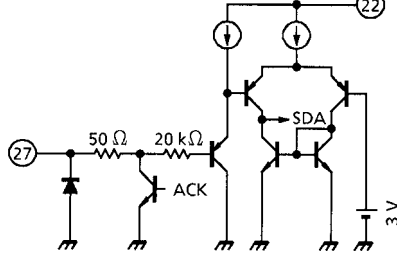
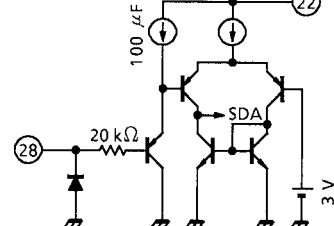
PIN NO.	PIN NAME	FUNCTION	INTERFACE	INPUT / OUTPUT SIGNAL
18	Sync output	Outputs sync signal which was separated in the sync separator circuit. Open collector output. Connect pull-up resistor.		
19	DEF GND	GND pin for DEF block.	—	—
20	AFC filter	Connect horizontal AFC filter. Pin voltage determines the horizontal output frequency.		DC
21	32f _H VDO	Connect ceramic oscillator for horizontal oscillation. Use Murata CSBLA503KECZF30.		
22	DEF V _{CC} (9 V)	V _{CC} for DEF block. Connect 9 V (typ.).	—	—
23	H output (SW)	Horizontal output pin. Connecting the pin to DEF V _{CC} changes mode to Double Scan. At this time, horizontal output is not produced.		HIGH: 3.2V LOW: 0.2V

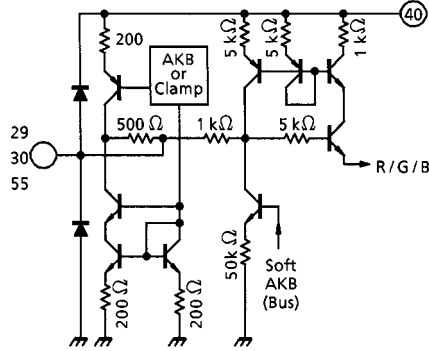
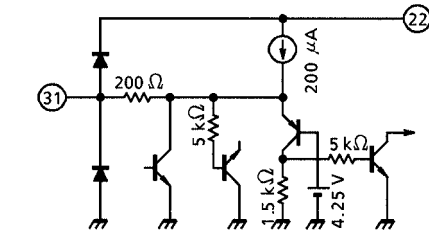
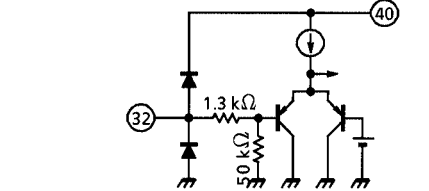
PIN NO.	PIN NAME	FUNCTION	INTERFACE	INPUT / OUTPUT SIGNAL
24	Curve correction (external CP / BPP input)	<p>(1) Normal Scan mode Corrects picture distortion at high voltage fluctuation.</p> <p>Input AC component of high voltage fluctuation.</p> <p>To disable curve correction function, connect 0.01 μF capacitor between pin and GND.</p> <p>(2) Double Scan mode Externally input clamp pulse.</p> <p>Also used as external BPP (black peak detection stopping pulse) input pin.</p>		<p>(1) DC 4.5 V</p> <p>(2)</p> <p>External clamp pulse</p> 
25	FBP input (H / V BLK input)	<p>Inputs FBP for generating pulse for horizontal AFC-2, Y smoothing, and horizontal blanking.</p> <p>Input horizontal blanking pulse of 5 V or more in Double Scan mode.</p>		
26	Digital GND	GND pin for I ² L block.	—	—
27	SDA	SDA pin for I ² C bus.		—
28	SCL	SCL pin for I ² C bus.		—

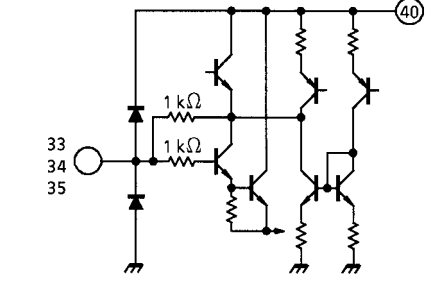
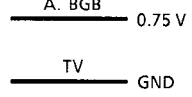
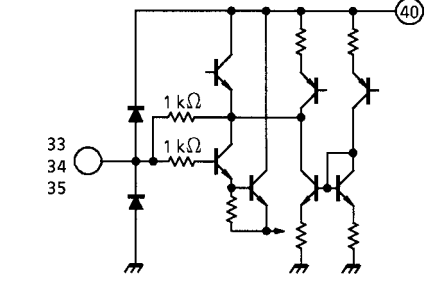
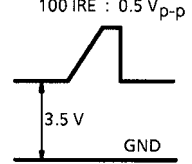
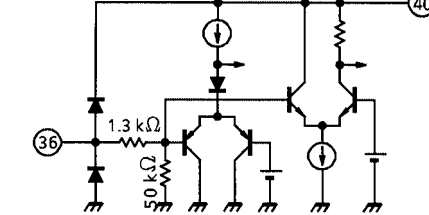
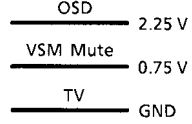
PIN NO.	PIN NAME	FUNCTION	INTERFACE	INPUT / OUTPUT SIGNAL
29	B sample-and-hold	Sample-and-hold pin in AKB or Clamp mode.		DC
30	G sample-and-hold	Connect 2.2 μF capacitor in AKB mode ; 0.1 μF capacitor in Clamp mode.		
31	VP output	Outputs vertical pulse. Also used as external blanking pulse input pin. When 350 μA or more current flows through the pin, blanking is applied by internal blanking and OR circuit.		
32	Y _S 2	Switches between internal RGB signal and analog RGB signal (pins 33, 34, 35). When set to on, VM output is muted.		
33	Analog B Input	Analog RGB input pins. Input RGB signal via clamp capacitor.		
34	Analog G Input			
35	Analog R input			
36	Y _S 1	Switches between internal RGB signal and OSD / analog RGB signal (pins 37, 38, 39). When set to on, VSM output is muted.		

PIN NO.	PIN NAME	FUNCTION	INTERFACE	INPUT / UTPUT SIGNAL
37	Analog OSD B input	OSD or analog RGB signal input pins. (1) Input OSD signal of 0 to 5 V (4.1 V or more). (2) Input analog RGB signal via clamp capacitor.		<p>(1)</p> <p>(2)</p> <p>100 IRE : 0.5 V_{p-p} DC : 3.6 V</p>
38	Analog OSD G input			
39	Analog OSD R input			
40	V _{CC2} (9 V)	V _{CC} pin for text block. Connect 9 V (typ.).	—	—
41	B output	Outputs RGB signal.		<p>100 IRE : 2.3 V_{p-p}</p> <p>2.5 V GND At Cont max BRT Cent.</p>
42	G output			
43	R output			
44	TEXT GND	GND pin for text block.	—	—
45	ABCL input	Controls external unicolor, brightness, and dynamic ABL. Use the pin to apply ABL or ACL. Using the I ² C bus, sensitivity and start point of ABL and dynamic ABL can be set.		ABCL OFF : 6 V or more
46	V _{CC3} (9 V)	V _{CC} pin for picture quality and color difference blocks. Connect 9 V (typ.).	—	—
47	Y _M input	Half-tone switch for internal RGB signal. Setting the pin voltage to 7.0 V or more raises RGB output to blanking level.		<p>Soft AKB ————— 7.0 V</p> <p>Half-tone ————— 0.75 V</p> <p>TV ————— GND</p>

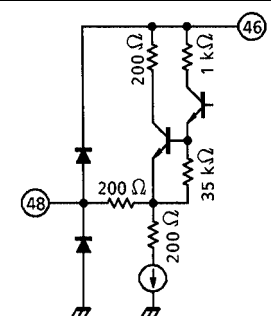
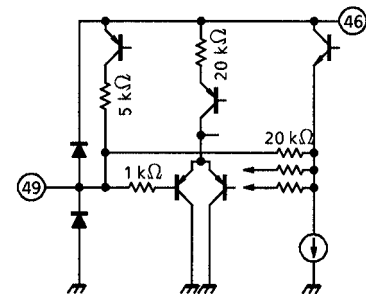
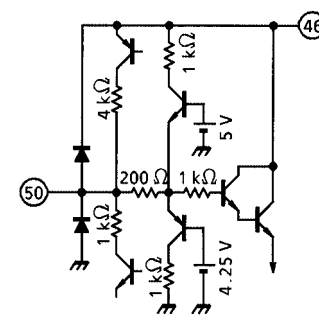
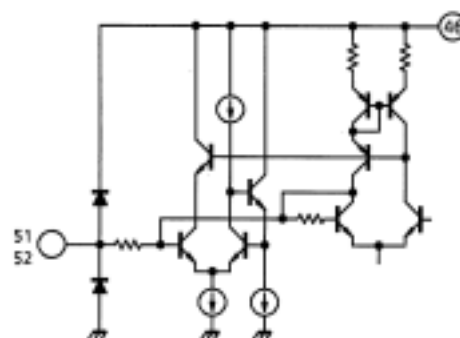
PIN NO.	PIN NAME	FUNCTION	INTERFACE	INPUT / UTPUT SIGNAL
48	VSM output	Outputs Y signal through HPF after DC restoration. Setting pins 32 and 36 to on mutes the output.		DC 3.5 V
49	APL detection	Connect filter used to correct DC restoration rate. The Y signal after black stretch can be monitored by leaving the pin open.		DC
50	Black peak hold	Connect filter used to control black stretch gain of the black stretcher circuit. The pin voltage determines black stretch gain.		DC
51 52	V / I input U / Q input	R-Y (V) / I and B-Y (U) / Q signal input pins. Input via clamp capacitor.		When burst chroma = 1 : 1 360 mV _{p-p} DC : 5.0 V

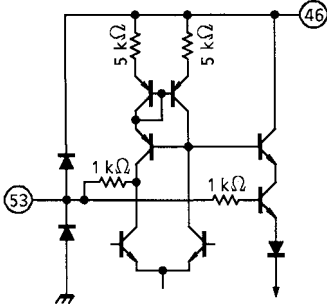
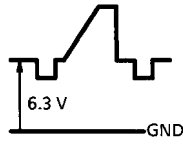
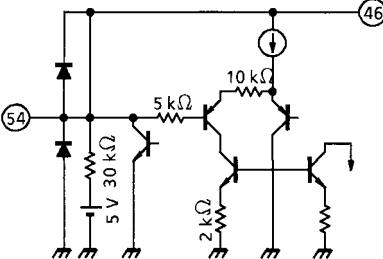
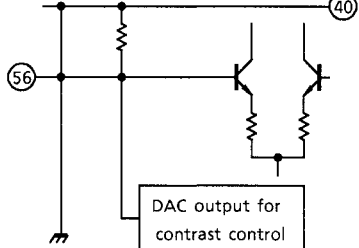
PIN NO.	PIN NAME	FUNCTION	INTERFACE	INPUT / OUTPUT SIGNAL
53	Y ₂ input	Y signal input pin. Input via clamp capacitor.		<p>1 V_{p-p} (including sync signal)</p> 
54	Color limiter	Connect filter used to detect color limit.		DC
55	R sample-and-hold	Same as pins 29 and 30.	Same as pins 29 and 30.	DC
56	DAC output for contrast control	Outputs DAC for contrast control. Connect 1 μF capacitor between this pin and GND		—

BUS CONTROL MAP

Write data

Slave address : 88H (10001000)

SUB-ADDRESS	D ₇ MSB	D ₆	D ₅	D ₄	D ₃	D ₂	D ₁	D ₀ LSB	POWER-ON PRESET VALUE	
									MSB	LSB
00	P-MUTE	UNI-COLOR							1000	0000
01	BRIGHTNESS								1000	0000
02	COLOR							Y-MUTE	1000	0000
03	TINT							YM-SW	1000	0000
04	PICTURE SHARPNESS					(YNR Level)	YNR	1000	0000	
05	RGB BRIGHTNESS							WPS	1000	0000
06	HI BRT	RGB CONTRAST							1000	0000
07	SUB COLOR					COLOR γ	CLT	1000	0000	
08	SUB CONTRAST					Y- γ CURVE	FLESH	1000	0000	
09	R (G) DRAIVE							DR-SW	1000	0000
0A	B DRIVE							Yout- γ	1000	0000
0B	HORIZONTAL POSITION					TEST2	V-OFF	H-BLK	1000	0000
0C	R CUT OFF								1000	0000
0D	G CUT OFF								1000	0000
0E	B CUT OFF								1000	0000
0F	R-Y PHASE	R / B GAIN			G / B GAIN		G-Y PHASE		0000	0000
10	COLOR SYSTEM			P / N-ID	BB SW	OSD-SL	OS-ACL	TX-ACL	0000	0000
11	VSM PHASE			VSM GAIN		APACON PEAK FREQ			0000	0000
12	DC RESTORATION POINT			DC RESTORATION RATE			DC REST. LIMIT		0000	0000
13	BLACK STRETCH POINT			APL VS BSP		Y- γ PNT	CDE		0000	0000
14	SHR-TRACKING	TEST1	RGB- γ	B.L.C.	B.S.G.	B.D.L.	BS-ARE	0000	0000	
15	DYNAMIC ABL POINT			DYNAMIC ABL GAIN			0	VM-LMT	0000	0000
16	ABL POINT			ABL GAIN			RGB OUT MODE		0000	0000
17	HD-OUT	V-BLK	VERTICAL FREQUENCY			VERTICAL POSITION			0000	0000
18	Y-DELAY TIME		TOF f_0			TOF-Q			0000	0000
19	DECODER TINT							C-TRAP	1000	0000

Note: Address 15H to D₁ are set to 0.

Read data

Slave address : 89H (10001001)

	D ₇	D ₆	D ₅	D ₄	D ₃	D ₂	D ₁	D ₀
0	PORES	COLOR SYSTEM		X'tal		V-FREQ	V-STD	H-LOCK
1	N-DET	RGBOUT	Y ₁ -IN	IQ-IN	Y ₂ -IN	H-OUT	VP-OUT	—

BUS CONTROL FUNCTIONS

Write function

REGISTER NAME	DESCRIPTION	POWER-ON PRESET VALUE
P-MUTE	Picture mute SW ; (0) : OFF, (1) : ON	ON
UNI-COLOR	Unicolor adjustment ; -17 dB to 0 dB	center
BRIGHTNESS	Brightness adjustment (including sub-adjustment) ; -37 IRE to +37 IRE	center
COLOR	Color adjustment ; -20 dB or more (color mute) to +4 dB	0 dB
Y-MUTE	Y mute SW ; (0) : ON, (1) : OFF	ON
TINT	Color adjustment ; -33° to +33°	0°
Y _M -SW	Halftone SW (YUV input) ; (0) : OFF, (1) : ON	OFF
SHARPNESS	Sharpness adjustment ; -20 dB to +15 dB	+10 dB
YNR-Level	YNR gain control ; (00) : max, (11) : flat at f YNR : When YNR ON, lower 2 bits of sharpness control are fixed to (00), upper 5 bits control sharpness.	(00)
YNR	Y noise reduction SW ; (0) : OFF, (1) : ON	OFF
RGB BRIGHTNESS	RGB brightness adjustment ; -20 IRE to +20 IRE	0 IRE
WPS L	White Peak suppressing level ; (0) : 130 IRE, (1) : 110 IRE	130 IRE
HI BRT	High bright color ; (0) : OFF, (1) : ON	OFF
RGB CONTRAST	RGB contrast ; -17 dB to 0 dB	-17 dB
SUB COLOR	Sub-color ; -5.9 dB to 0 dB to +3.5 dB	0 dB
COLOR γ	Color γ correction point ; (00) : OFF, (01) : 0.23 V _{p-p} , (10) : 0.4 V _{p-p} , (11) : 0.58 V _{p-p}	OFF
CLT	Color limiter level ; (0) : 1.65 V _{p-p} , (11) : 2 V _{p-p}	1.65 V _{p-p}
SUB CONTRAST	Sub-contrast adjustment ; -3.3 dB to +2.5 dB	0 dB
Y- γ CURVE	Y- γ curve SW ; (00) : OFF, (01) : -2.5 dB, (10) : -4.8 dB, (11) : -6.5 dB	OFF
FLESH	Flesh color ; (0) : OFF, (1) : ON	OFF
G (R) / B DRIVE	R (G) / B drive gain ; -5 dB to 0 dB to +3 dB	0 dB (40h)
DG-SW	Drive gain base axis SW ; (0) : G, (1) : R	G
Yout- γ	Y γ (contrast stage or later) SW ; (0) : OFF, (1) : ON	OFF
HORIZONTAL POSITION	Horizontal position adjustment ; -3 μ s to +3 μ s	0 μ s
TEST2	IC test mode SW Fix to (0) for use	OFF
V-OFF	Vertical output SW ; (0) : ON, (1) : OFF	ON
H-BLK	Horizontal blanking SW ; (0) : ON, (1) : OFF	ON
R / G / B CUTOFF	R / G / B cutoff adjustment ; <ul style="list-style-type: none"> When AKB-OFF, RGB output : 2 V to 2.5 V to 3 V When AKB-ON, SENS input : 1.0 V_{p-p} to 1.5 V_{p-p} to 2.0 V_{p-p} (\pm5 IRE) 	Center (80h)
R-Y PHASE	R-Y phase SW ; (00) : 90°, (01) : 92°, (10) : 94°, (11) : 111°	90°
R / B GAIN	R / B relative phase SW ; (00) : 0.58, (01) : 0.7, (10) : 0.81, (11) : 0.88	0.58
G / B GAIN	G / B relative phase SW ; (00) : 0.31, (01) : 0.35, (10) : 0.42, (11) : 0.48	0.31

REGISTER NAME	DESCRIPTION	POWER-ON PRESET VALUE																																													
G-Y PHASE	G-Y relative phase SW ; (00) : 237°, (01) : 241°, (10) : 245°, (11) : 254°	237°																																													
COLOR SYSTEM	Color signal system ; <table border="1" style="margin-left: 40px; border-collapse: collapse;"> <thead> <tr> <th>System</th> <th>X'tal</th> <th>Color difference mute</th> <th>Color difference input</th> <th>TINT control</th> </tr> </thead> <tbody> <tr> <td>(000) : NTSC</td> <td>3.58</td> <td>Forced OFF</td> <td>I / Q</td> <td>Yes</td> </tr> <tr> <td>(001) : NTSC</td> <td>3.58</td> <td>Forced OFF</td> <td>U / V</td> <td>Yes</td> </tr> <tr> <td>(010) : NTSC</td> <td>4.43</td> <td>Forced OFF</td> <td>U / V</td> <td>Yes</td> </tr> <tr> <td>(011) : PAL</td> <td>4.43 (N)</td> <td>Forced OFF</td> <td>U / V</td> <td>Yes</td> </tr> <tr> <td>(100) : PAL</td> <td>M</td> <td>Forced OFF</td> <td>U / V</td> <td>Yes</td> </tr> <tr> <td>(101) : SECAM</td> <td>4.43</td> <td>Forced OFF</td> <td>U / V</td> <td>Yes</td> </tr> <tr> <td>(110) : MULTI</td> <td>3.58 / 4.43</td> <td>Forced OFF</td> <td>U / V</td> <td>Yes</td> </tr> <tr> <td>(111) : Trinorma</td> <td>3.58 / M / N</td> <td>Forced OFF</td> <td>U / V</td> <td>Yes</td> </tr> </tbody> </table>	System	X'tal	Color difference mute	Color difference input	TINT control	(000) : NTSC	3.58	Forced OFF	I / Q	Yes	(001) : NTSC	3.58	Forced OFF	U / V	Yes	(010) : NTSC	4.43	Forced OFF	U / V	Yes	(011) : PAL	4.43 (N)	Forced OFF	U / V	Yes	(100) : PAL	M	Forced OFF	U / V	Yes	(101) : SECAM	4.43	Forced OFF	U / V	Yes	(110) : MULTI	3.58 / 4.43	Forced OFF	U / V	Yes	(111) : Trinorma	3.58 / M / N	Forced OFF	U / V	Yes	NTSC (000)
System	X'tal	Color difference mute	Color difference input	TINT control																																											
(000) : NTSC	3.58	Forced OFF	I / Q	Yes																																											
(001) : NTSC	3.58	Forced OFF	U / V	Yes																																											
(010) : NTSC	4.43	Forced OFF	U / V	Yes																																											
(011) : PAL	4.43 (N)	Forced OFF	U / V	Yes																																											
(100) : PAL	M	Forced OFF	U / V	Yes																																											
(101) : SECAM	4.43	Forced OFF	U / V	Yes																																											
(110) : MULTI	3.58 / 4.43	Forced OFF	U / V	Yes																																											
(111) : Trinorma	3.58 / M / N	Forced OFF	U / V	Yes																																											
P / N ID	PAL / NTSC identification sensitivity SW ; (0) : LOW (when using digital comb filter), (1) : Hi	LOW																																													
BB SW	Blue background SW ; (0) : OFF, (1) : ON	OFF																																													
OSD-SL	OSD peak suppressing level SW ; (0) : 93 IRE, (1) : 76 IRE	93 IRE																																													
OS-ACL	OSD ACL SW ; (0) : ON, (1) : OFF	ON																																													
TX-ACL	RGB ACL SW ; (0) : -6 dB : Normal	-6 dB																																													
VSM PHASE	VSM output phase SW ; APACON peak frequency : f4M or less ; (000) : -120 ns, (001) : -120 ns, (010) : 80 ns, (011) : -40 ns, (100) : -20 ns, (101) : Normal (100 ns before RGB output), (110) : +20 ns, (111) : +40 ns	100 ns before RGB output																																													
	APACON peak frequency : f8M or less ; (000) : -40 ns, (001) : -32.5 ns, (010) : -25 ns, (011) : -17.5 ns, (100) : -10 ns, (101) : Normal (65 ns before RGB output), (110) : +10 ns, (111) : +20 ns	65 ns before RGB output																																													
VSM GAIN	VSM output gain SW ; (00) : 0 dB, (01) : -6 dB, (10) : -9 dB, (11) : OFF	0 dB																																													
APACON PEAK f ₀	APACON peak frequency SW. ; (000) : through, (001) : 4.2 MHz, (010) : 3.3 MHz, (011) : 2.5 MHz (100) : through, (101) : 14 MHz, (110) : 11 MHz, (111) : 7.7 MHz	(000) through																																													
DC RESTORATION POINT	DC transmission rate correction start point ; (000) : 0% to (111) : 47%	0%																																													
DC RESTORATION RATE	DC transmission rate correction ; (000) : 100% to (111) : 135%	100%																																													
DC REST. LIMIT	DC transmission rate correction limit point ; (APL) (00) : 100%, (01) : 87%, (10) : 73%, (11) : 60%	100%																																													
BLACK STRECH POINT (BSP)	Black stretch start point ; When APL = 0%, (000) : 22 IRE to (111) : 56 IRE	22 IRE																																													
APL VS BSP (AVS)	APL level vs black stretch start point ; (00) : 0 dB to (11) : 5.5 dB, BSP + APL × BSP × AVS	0 dB																																													

REGISTER NAME	DESCRIPTION	POWER-ON PRESET VALUE
Y-γ PNT	Y-γ point SW ; (0) : 100 IRE, (1) : 95 IRE	100 IRE
C.D.E.	Color detail enhancer ; (11) : max (forced OFF when Through), (00) : OFF	ON
SHR-TRACKING	Sharpness tracking ; (00) : HIGH, (11) : LOW	HIGH
TEST	Test mode ; (0) : NORMAL (1) : Test mode (for factory test) Mode switched by sub-address 17H data. <Gate pulse period> D ₂ (0) : V-BLK period only, D ₂ (1) : NORMAL Y / RGB smoothing OFF, Monitor HD output by DAC	NORMAL
RGB-γ	RGB-γ SW ; (0) : OFF, (1) : ON	OFF
B.L.C.	Black level automatic correction (black stretch prioritized) ; Max 7.5 IRE (0) : OFF, (1) : ON	OFF
B.S.G.	Black stretch gain SW ; (0) ON, (1) : OFF	ON
B.D.L.	Black detection level SW ; (0) : 3 IRE, (1) : 0 IRE	3 IRE
BS-ARE	Black area reinforcement SW ; For wide TV (when using time axis compression IC) (0) : ON, (1) : OFF	ON
DYNAMIC ABL POINT	Dynamic ABL detection voltage ; (000) : min to (111) : max	min
DYNAMIC ABL GAIN	Dynamic ABL sensitivity ; (000) : min to (111) : max	min
VM-LMT	VM limiter SW ; (0) : OFF, (1) : ON (gain increased by 6 dB / 1.4 V _{p-p})	OFF
ABL POINT	ABL detection voltage ; (000) : min to (111) : max	min
ABL GAIN	ABL sensitivity ; (000) : min to (111) : max	min
RGB OUT MODE	RGB Output mode SW ; (00) : NORMAL, (01) : R only, (10) : G only, (11) : B only	NORMAL
HD-OUT	HD output SW ; (0) : HD output, (1) : pulse output during AKB	HD output
V-BLK	Vertical blanking SW ; (0) : ON, (1) : OFF	ON
VERTICAL FREQUENCY	Vertical frequency ; (000) : AUTO (50, 60 Hz), (001) : AUTO (50, 60 Hz / V MASK OFF), (010) : 60 Hz, (011) : 60 Hz (V MASK OFF), (100) : 262.5H fixed, (101) : 263H fixed, (110) : 312.5H fixed, (111) : 313H fixed, When set to (100), (101), (110), or (111), AFC is free running.	(000) AUTO
VERTICAL POSITION	Vertical position adjustment ; (000) : 0H to (111) : 7H (in 1H STEP)	0H
Y-DELAY TIME	Y delay time SW ; (00) OFF, (01) : +40 ns ; (10) : +80 ns ; (11) : +120 ns	OFF
TOF-f ₀	TOF peak frequency SW ; (000) : TOF OFF, (001) : 0.92 f _{sc} to (111) : 1.73 f _{sc}	TOF OFF
TOR-Q	TOF Q SW ; (000) : 0.6 to (111) : 1.2	0.6
DECORDER TINT	Hue adjustment : -32° to +32° (1 STEP = 0.5°)	0°
C-TRAP	Chroma trap SW ; (0) : OFF, (1) : ON	OFF

DELAY TIME FROM Y₁ INPUT (PIN 15) TO Y₁ OUTPUT (PIN 4)

COLOR SIGNAL	TRAP	Y-DL	DELAY TIME
B / W	—	OFF (00)	365 ns
		(01)	415 ns
		(10)	465 ns
		(11)	515 ns
PAL / NTSC	OFF	OFF (00)	365 ns (4.43)
		OFF (00)	365 ns (3.58 / M / N)
		(01)	415 ns (4.43)
		(01)	415 ns (3.58 / M / N)
		(10)	465 ns (4.43)
		(10)	465 ns (3.58 / M / N)
		(11)	515 ns (4.43)
		(11)	515 ns (3.58 / M / N)
	ON	OFF (00)	355 ns (4.43)
		OFF (00)	360 ns (3.58 / M / N)
		(01)	405 ns (4.43)
		(01)	410 ns (3.58 / M / N)
		(10)	455 ns (4.43)
		(10)	460 ns (3.58 / M / N)
SECAM	—	OFF (00)	580 ns
		(01)	630 ns
		(10)	680 ns
		(11)	730 ns

READ FUNCTION

REGISTER NAME	DESCRIPTION
PORES	Power-on reset ; (0) : RESESTER PRESET, (1) : NORMAL
COLOR SYSTEM	Color signal being received (detection of ID / no ID) (00) : B / W, (01) : SECAM, (10) : PAL, (11) : NTSC
X'tal	X'tal mode ; (00) : —, (01) : 4.43 (N), (10) : M, (11) : 3.58
V-FREQ	Vertical frequency ; (0) : 50 Hz, (1) : 60 Hz
V-STD	Vertical standard detection ; (0) NON-STANDARD, (1) : STANDARD
H-LOCK	Horizontal lock detection ; (0) : LOCK, (1) : NON-LOCK
N-DET	Noise detection ; (0) : some, (1) : lots
RGBOUT, Y ₁ -IN, IQ-IN, Y ₂ -IN, H-OUT, VP-OUT	Self-diagnose result output ; (0) : NG, (1) : OK

MAXIMUM RATINGS (Ta = 25°C)

PARAMETER	SYMBOL	RATING	UNIT
Supply Voltage	V _{CCmax}	12	V
Input Pin Signal Voltage	e _{inmax}	9	V _{p-p}
Power Dissipation	P _D (Note 1)	1920	mW
Power Dissipation Reduction Rate	1 / Q _{ja}	15.4	mW / °C
Operating Temperature	T _{opr}	-20~65	°C
Storage Temperature	T _{stg}	-55~150	°C

Note 1: See the graph below.

Note 2: Since the device is susceptible to surge, handle with care.

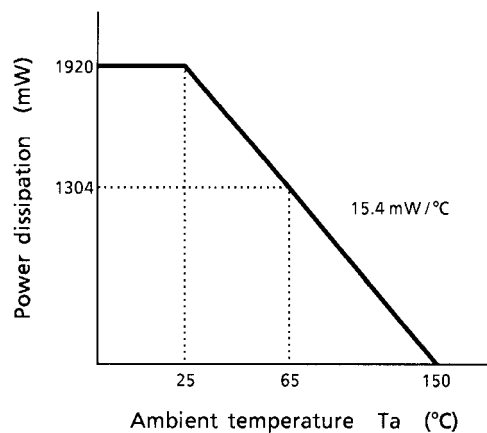

Fig. Power dissipation vs temperature

RECOMMENDED OPERATING CONDITIONS

PARAMETER	DESCRIPTION	MIN	TYP.	MAX	UNIT
Supply Voltage	pin 5	4.3	5.0	5.3	V
	Pins 22, 40, 46	8.7	9.0	9.3	
Y ₁ / Sync, Y ₂ Input Signal Level	White : 100%, including synchronization (negative sync pulse)	0.9	1.0	1.1	V _{p-p}
Chroma Input Signal Level	TOF : OFF (burst level)	200	300	400	mV _{p-p}
	TOF : ON (burst level)	100	200	300	
I / Q, U / V Input Level	B : C = 1 : 1	—	300	—	mV _{p-p}
OSD / Analog RGB Input Level	OSD input	4.2	—	5.0	V
	Analog input	0.4	0.5	0.6	
Analog RGB Input Level	—	0.4	0.5	0.6	V _{p-p}
FBP Width	—	11	12	13	μs
FBP Input Current	—	—	—	1.5	mA
RGB Output Current	—	—	1.0	2.0	
Horizontal Output Current	—	—	3.0	10.0	
Pin 18 Input Current	—	—	0.5	1.0	

ELECTRICAL CHARACTERISTICS(Unless otherwise specified, $V_{CC1} = 5\text{ V}$, $V_{CC2} / V_{CC3} / \text{DEF } V_{CC} = 9\text{ V}$, $T_a = 25^\circ\text{C}$)**Current dissipation**

PIN NAME	SYMBOL	TEST CIR-CUIT	MIN	TYP.	MAX	UNIT
V_{CC1}	I_{CC1}	—	37.6	43.4	49.9	mA
V_{CC2}	I_{CC2}	—	37.6	43.3	49.8	
V_{CC3}	I_{CC3}	—	36.2	41.7	48.0	
DEF V_{CC}	I_{CC4}	—	9.7	11.2	13.0	

PACKAGE DIMENSIONS

SDIP56-P-600-1.78

Unit : mm

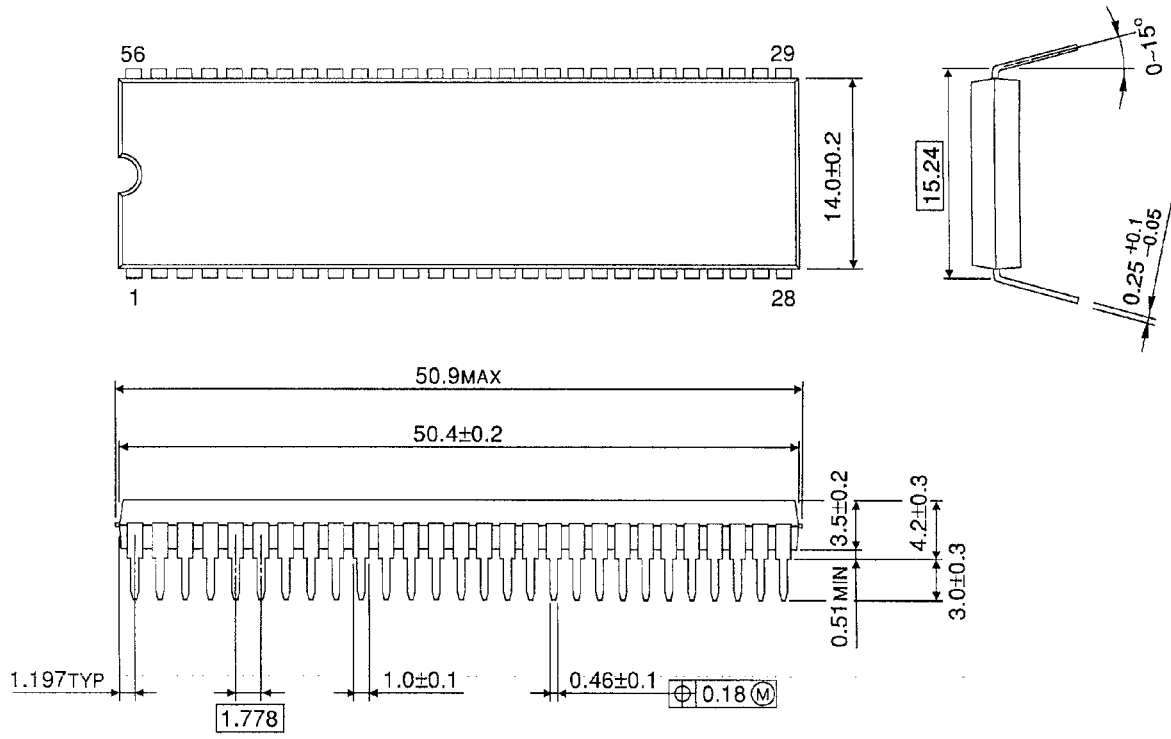

Weight: 5.55 g (Typ.)

RESTRICTIONS ON PRODUCT USE

000707EBA

- TOSHIBA is continually working to improve the quality and reliability of its products. Nevertheless, semiconductor devices in general can malfunction or fail due to their inherent electrical sensitivity and vulnerability to physical stress. It is the responsibility of the buyer, when utilizing TOSHIBA products, to comply with the standards of safety in making a safe design for the entire system, and to avoid situations in which a malfunction or failure of such TOSHIBA products could cause loss of human life, bodily injury or damage to property.
In developing your designs, please ensure that TOSHIBA products are used within specified operating ranges as set forth in the most recent TOSHIBA products specifications. Also, please keep in mind the precautions and conditions set forth in the "Handling Guide for Semiconductor Devices," or "TOSHIBA Semiconductor Reliability Handbook" etc..
- The TOSHIBA products listed in this document are intended for usage in general electronics applications (computer, personal equipment, office equipment, measuring equipment, industrial robotics, domestic appliances, etc.). These TOSHIBA products are neither intended nor warranted for usage in equipment that requires extraordinarily high quality and/or reliability or a malfunction or failure of which may cause loss of human life or bodily injury ("Unintended Usage"). Unintended Usage include atomic energy control instruments, airplane or spaceship instruments, transportation instruments, traffic signal instruments, combustion control instruments, medical instruments, all types of safety devices, etc.. Unintended Usage of TOSHIBA products listed in this document shall be made at the customer's own risk.
- The products described in this document are subject to the foreign exchange and foreign trade laws.
- The information contained herein is presented only as a guide for the applications of our products. No responsibility is assumed by TOSHIBA CORPORATION for any infringements of intellectual property or other rights of the third parties which may result from its use. No license is granted by implication or otherwise under any intellectual property or other rights of TOSHIBA CORPORATION or others.
- The information contained herein is subject to change without notice.