

30W BTL×2CH AUDIO POWER AMPLIFIER

The thermal resistance θ_{j-T} of TA8221AH, TA8221AL package designed for low thermal resistance, has a high efficiency of heat radiation.

The temperature rise of chip can be reduced and the influence from the degradation of the features due to the temperature rise at the high output can also be reduced.

This stereo audio power IC, designed for car audio use, has two built-in channels to reduce the characteristic difference between L and R channels.

It also contains various kind of protection.

FEATURES

- Low Thermal Resistance
: $\theta_{j-T} = 1.5^{\circ}\text{C}/\text{W}$ (Infinite Heat Sink)
- High Power
: $P_{\text{OUT}}(1) = 30\text{W}$ (Typ.) / Channel
($V_{\text{CC}} = 14.4\text{V}$, $f = 1\text{kHz}$, $\text{THD} = 10\%$, $R_{\text{L}} = 2\Omega$)
 $P_{\text{OUT}}(2) = 26\text{W}$ (Typ.) / Channel
($V_{\text{CC}} = 13.2\text{V}$, $f = 1\text{kHz}$, $\text{THD} = 10\%$, $R_{\text{L}} = 2\Omega$)
 $P_{\text{OUT}}(3) = 19\text{W}$ (Typ.) / Channel
($V_{\text{CC}} = 13.2\text{V}$, $f = 1\text{kHz}$, $\text{THD} = 10\%$, $R_{\text{L}} = 4\Omega$)
- Low Distortion Ratio : $\text{THD} = 0.04\%$ (Typ.) ($V_{\text{CC}} = 13.2\text{V}$, $f = 1\text{kHz}$, $P_{\text{OUT}} = 1\text{W}$, $R_{\text{L}} = 4\Omega$, $G_{\text{V}} = 50\text{dB}$)
- Low Noise : $V_{\text{NO}} = 0.30\text{mV}_{\text{RMS}}$ (Typ.) ($V_{\text{CC}} = 13.2\text{V}$, $R_{\text{L}} = 4\Omega$, $G_{\text{V}} = 50\text{dB}$, $R_{\text{G}} = 0\Omega$, $\text{BW} = 20\text{Hz} \sim 20\text{kHz}$)
- Built-in Stand-by Function (With pin④ set at LOW, power is turned OFF.) : $I_{\text{SB}} = 100\mu\text{A}$ (Typ.)
- Built-in Muting Function (With pin① set at LOW, power is turned OFF.)
- Built-in Various Protection Circuits
Protection Circuits : Thermal Shut Down, Over Voltage, Out→ V_{CC} Short, Out→GND Short and OUT-OUT Short.
- Operating Supply Voltage : $V_{\text{CC}}(\text{opr}) = 9 \sim 18\text{V}$

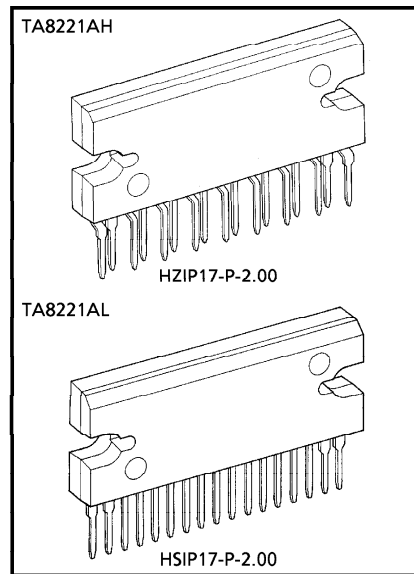

Weight
HZIP17-P-2.00 : 9.8g (Typ.)
HSIP17-P-2.00 : 9.8g (Typ.)

● The information contained herein is presented only as a guide for the applications of our products. No responsibility is assumed by TOSHIBA CORPORATION for any infringements of intellectual property or other rights of the third parties which may result from its use. No license is granted by implication or otherwise under any intellectual property or other rights of TOSHIBA CORPORATION or others.

● TOSHIBA is continually working to improve the quality and the reliability of its products. Nevertheless, semiconductor devices in general can malfunction or fail due to their inherent electrical sensitivity and vulnerability to physical stress. It is the responsibility of the buyer, when utilizing TOSHIBA products, to observe standards of safety, and to avoid situations in which a malfunction or failure of a TOSHIBA product could cause loss of human life, bodily injury or damage to property.

In developing your designs, please ensure that TOSHIBA products are used within specified operating ranges as set forth in the most recent products specifications. Also, please keep in mind the precautions and conditions set forth in the TOSHIBA Semiconductor Reliability Handbook.

TA8221AH - 1

1996-09-02

TOSHIBA CORPORATION

BLOCK DIAGRAM

TA8221AH, TA8221AL ($G_V = 50\text{dB}$)

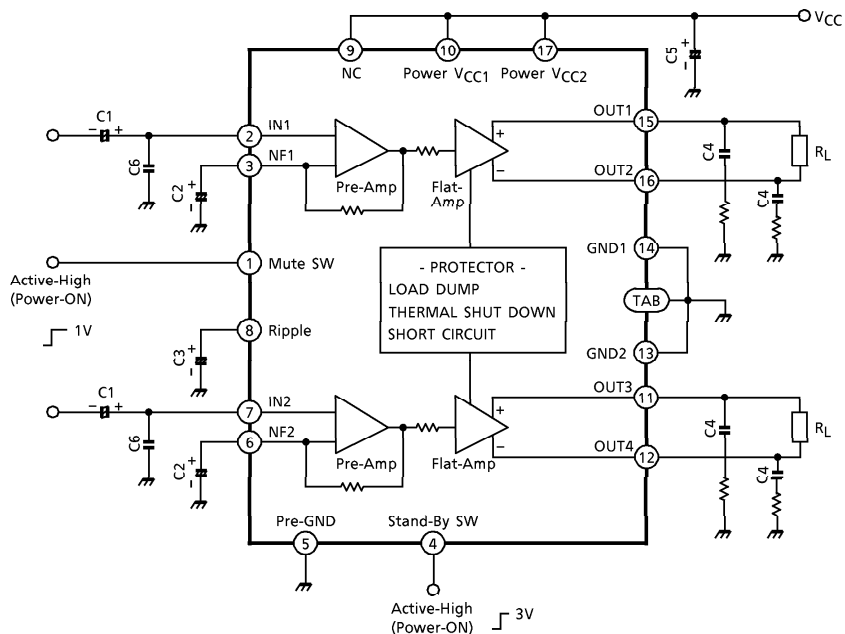

CAUTION AND APPLICATION METHOD

(Description is made only on the single channel.)

1. Voltage gain adjustment

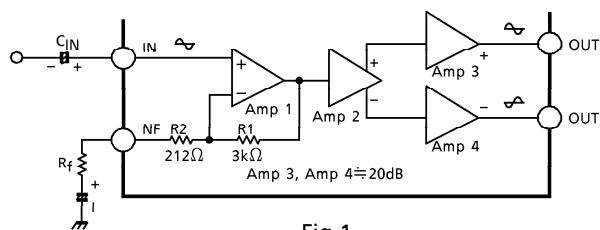

Fig.1

This IC has the amplifier constructions as shown Fig.1. The Pre-Amp (Amp 1) is provided to the primary stage, and the input voltage is amplified by the Flat Amps, Amp 3 and Amp 4 of each channel through the phase Amp (Amp 2).

Since the input offset is prevented by Pre-Amp when V_{CC} is set to ON, this circuit can remarkably reduce the pop noise.

TA8221AH - 2
1996-09-02
TOSHIBA CORPORATION

The total closed loop gain G_V of this IC can be obtained by expression below when the closed loop voltage gain of Amp 1 is G_{V1} .

$$G_{V1} = 20 \log \frac{R1 + (R_f + R2)}{R_f + R2} \text{ (dB)} \dots\dots (1)$$

The closed loop voltage gain of POWER Amp, Amp 3 and Amp 4 is fixed at $G_{V3} \cong G_{V4} = 20\text{dB}$.

Therefore, the total closed circuit voltage gain G_V is obtained through BTL connection by the expression below.

$$G_V = G_{V1} + G_{V3} + 6 \text{ (dB)} \dots\dots\dots (2)$$

For example, when $R_f = 0\Omega$, G_V is obtained by the expressions (1) and (2) as shown below.

$$G_V \cong 24 + 20 + 6 = 50\text{dB}$$

The voltage gain is reduced when R_f is increased. (Fig.2) With the voltage gain reduced, since (1) the oscillation stability is reduced, and (2) the pop noise changes when V_{CC} is set to ON, refer to the items 3 and 4.

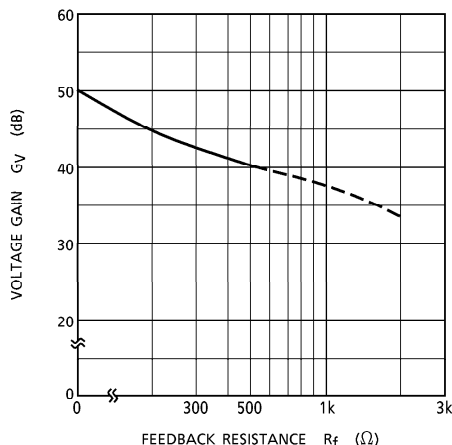

Fig.2

2. Stand-by SW function

By means of controlling pin④ (Stand-by terminal) to High and Low, the power supply can be set to ON and OFF. The threshold voltage of pin④ is set at 2.1V ($3V_{BE}$), and the power supply current is about $100\mu\text{A}$ (Typ.) at the stand-by state.

Control voltage of pin④ : $V(SB)$

STAND-BY	POWER	$V(SB)$ (V)
ON	OFF	0~2
OFF	ON	3~ V_{CC}

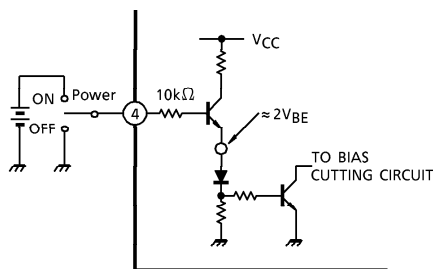
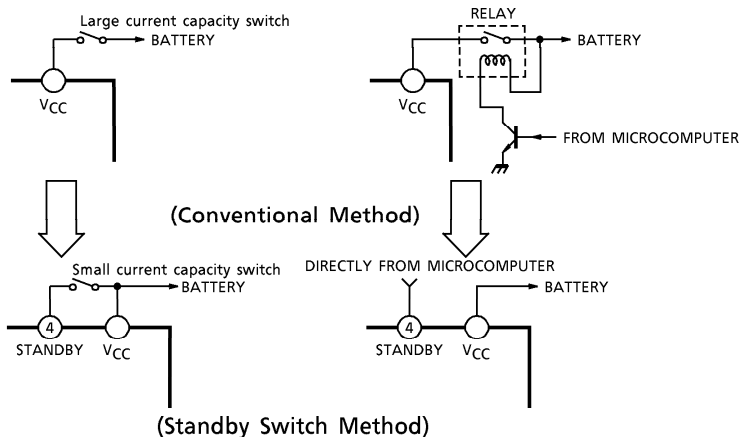

Fig.3 With pin④ set to High, Power is turned ON.

Adjustage of stand-by SW

- (1) Since V_{CC} can directly be controlled to ON/OFF by the microcomputer, the switching relay can be omitted.
- (2) Since the control current is microscopic, the switching relay of small current capacity is satisfactory for switching.



3. Preventive measure against oscillation

For preventing the oscillation, it is advisable to use C4, the condenser of polyester film having small characteristic fluctuation of the temperature and the frequency. The condenser (C6) between input and GND is effective for preventing oscillation which is generated with a feedback signal from an output stage. The resistance R to be series applied to C4 is effective for phase correction of high frequency, and improves the oscillation allowance.

- (1) Voltage gain to be used (G_V Setting)
- (2) Capacity value of condenser
- (3) Kind of condenser
- (4) Layout of printed board

In case of its use with the voltage gain G_V reduced or with the feedback amount increased, care must be taken because the phase-inversion is caused by the high frequency resulting in making the oscillation liable generated.

4. Adjustment of output offset (When the power supply turn on)

As this IC is constructed with DC circuit on the primary stage, it is necessary to lower a input offset or output offset by agreement with the each leading edge time constant of the input voltage in the primary stage and NF terminal voltage. Concretely, monitor the output DC voltage and vary the capacity value in input condenser and NF condenser (See Fig.4)

(Reference) In case of setting the condition ($G_V = 40\text{dB}$) with $R_f = 470\Omega$.

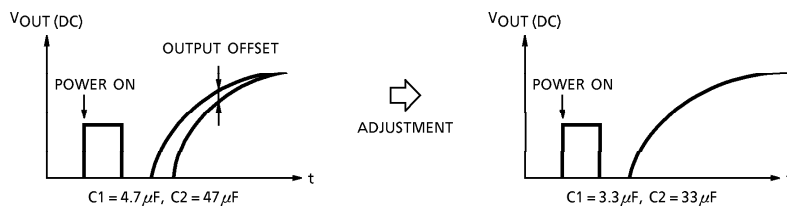

Fig.4

5. Muting function

Through setting pin① (mute terminal) at about 1V or less, muting becomes possible.

The interval circuit of IC is shown in Fig.5.

When pin① is set to LOW, Q1 and Q2 are turned to ON, the charge of the ripple condenser is discharged and the bias is cut. The mute amount of 60dB or over can be obtained.

Since this muting function rapidly discharge the charge of the ripple filter capacitor of pin⑧, the pop noise is generated by the DC fluctuation of the bias section.

Therefore, this muting function is not appropriate to the audio muting but it is effective in muting at $V_{CC} \rightarrow ON$.

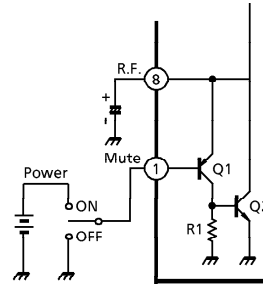

Fig.5 Mute circuit

6. Rapid ripple discharging circuit at the time of V_{CC} OFF

This circuit is effective in such a mode where the V_{CC} and the Stand-by terminals become high/low simultaneously ; for instance, for a pop noise produced when the power is turned ON/OFF repeatedly by operating the ignition key.

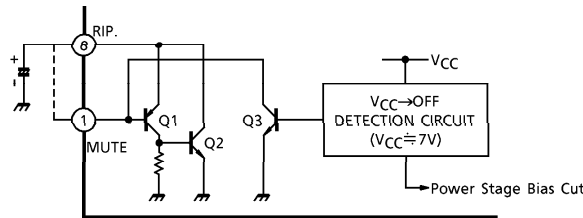

Fig.6

If V_{CC} is OFF, $V_{CC} \approx 7V$ is detected internally on IC and

- (1) The power stage bias circuit is cut, and
- (2) Pin⑧ : Ripple Capacitor is rapidly discharged by turning Q3 ON and then Q1 and Q2 ON.

(Precaution 1)

When the stand-by terminal was put to the low level after the ripple rapid discharging circuit was operated ($V_{CC} \approx 7V$) at the time when V_{CC} was turned OFF, a pop noise may be generated. Therefore, V_{CC} which makes the Stand-by terminal low shall be set at 8V or above so that (1) the Stand-by terminal is put at the low level and (2) the ripple rapid discharging circuit is turned ON when V_{CC} is turned OFF (in order of (1) and (2)).

An example of application is shown in (Fig.7).

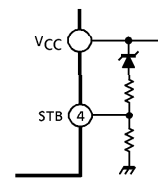

Fig.7

(Precaution 2)

If the falling time constant of the V_{CC} line is large (the fall is gentle), the pop noise may become worse.

In this case, it is possible to prevent the pop noise from becoming worse by reducing the capacity of "Ripple Rapid Discharging Circuit at the time of V_{CC} OFF" according to the following steps :

- (a) Short pin① (Mute Terminal) and pin⑧ (Ripple Terminal).
- (b) Increase the capacity of ripple capacitor of pin⑧.

However, it shall be kept in mind that the time for turning the power ON becomes longer as the result of step (b).

7. External part list and description

SYM-BOL	RECOM-MENDED VALUE	FEATURE	INFLUENCE		REMARKS
			SMALLER THAN RECOMMENDED VALUE	LARGER THAN RECOMMENDED VALUE	
C1	4.7 μ F	DC blocking	Related to pop noise at V_{CC} →ON.		Related to gain. Refer to item 4.
C2	47 μ F	Feedback condenser	Related to pop noise at V_{CC} →ON. Determination of low cut-off frequency. $C2 = \frac{1}{2\pi \cdot f_L \cdot R_f}$		
C3	220 μ F	Ripple reduction	Time constant is small at V_{CC} →ON or OFF.	Time constant is large at V_{CC} →ON or OFF.	
C4	0.12 μ F	Oscillation prevention	Made liable to oscillate.	Oscillation allowance.	Refer to item 3.
C5	1000 μ F	Ripple filter	For filtering power supply hum and ripple. Large at using AC rectified power supply. Small at using DC power supply.		
C6	1000pF	Oscillation prevention	Oscillation allowance improved. Noise reduction		Refer to item 3.

MAXIMUM RATINGS (Ta = 25°C)

CHARACTERISTIC	SYMBOL	RATING	UNIT
Peak Supply Voltage (0.2s)	V _{CC} (surge)	50	V
DC Supply Voltage	V _{CC} (DC)	25	V
Operating Supply Voltage	V _{CC} (opr)	18	V
Output Current (Peak)	I _O (peak)	9	A
Power Dissipation	P _D	50	W
Operating Temperature	T _{opr}	-30~85	°C
Storage Temperature	T _{stg}	-55~150	°C

ELECTRICAL CHARACTERISTICS

(Unless otherwise specified, V_{CC} = 13.2V, R_L = 4Ω, f = 1kHz, Ta = 25°C)

CHARACTERISTIC	SYMBOL	TEST CIRCUIT	TEST CONDITION	MIN.	TYP.	MAX.	UNIT
Quiescent Supply Current	I _{CCQ}	—	V _{IN} = 0	—	120	250	mA
Output Power	P _{OUT} (1)	—	V _{CC} = 14.4V, R _L = 2Ω, THD = 10%	—	30	—	W
	P _{OUT} (2)	—	R _L = 2Ω, THD = 10%	17	26	—	
	P _{OUT} (3)	—	THD = 10%	16	19	—	
Total Harmonic Distortion Ratio	THD	—	P _{OUT} = 1W	—	0.04	0.4	%
Voltage Gain	G _V	—	—	48	50	52	dB
Voltage Gain Ratio	ΔG _V	—	—	-1.0	0	1.0	dB
Output Noise Voltage	V _{NO}	—	R _g = 0Ω, BW = 20Hz~20kHz	—	0.3	0.7	mV _{rms}
Ripple Rejection Ratio	R.R.	—	fripple = 100Hz, R _g = 600Ω	40	54	—	dB
Input Resistance	R _{IN}	—	—	—	30	—	kΩ
Output Offset Voltage	V _{offset}	—	V _{IN} = 0	-100	0	100	mV
Current at Stand-by State	I _{SB}	—	—	—	100	150	μA
Cross Talk	C.T.	—	R _g = 600Ω, V _{OUT} = 0.775V _{rms} (0dBm)	—	60	—	dB
Pin④ Control Voltage	V _{SB}	—	Stand-by→OFF (Power→ON)	2.5	—	V _{CC}	V
Pin① Control Voltage	V (Mute)	—	Mute→ON (Power→OFF)	—	1.0	2.0	V

TA8221AH - 7

1996-09-02

TOSHIBA CORPORATION

TEST CIRCUIT

TA8221AH, TA8221AL ($G_V = 50\text{dB}$)

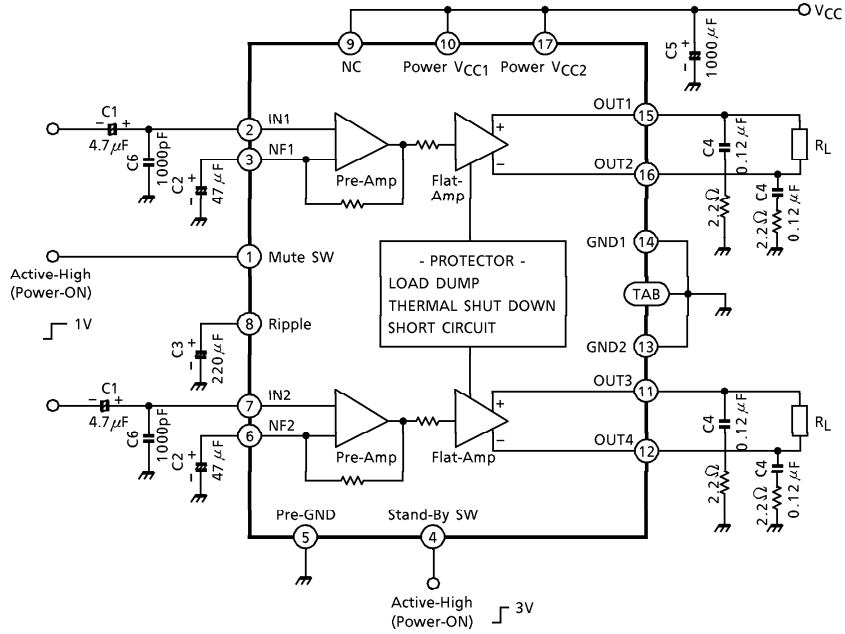

TA8221AH - 8

1996-09-02

TOSHIBA CORPORATION

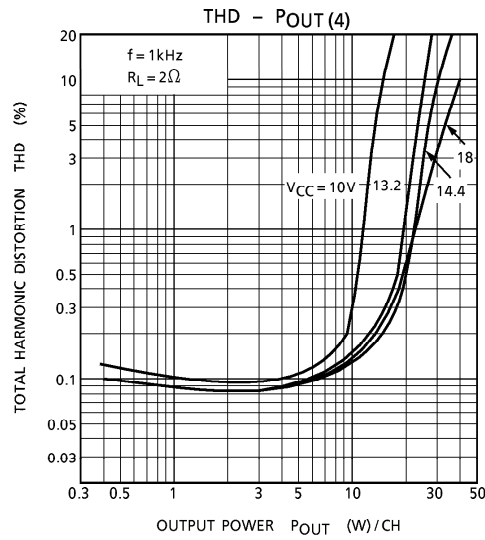
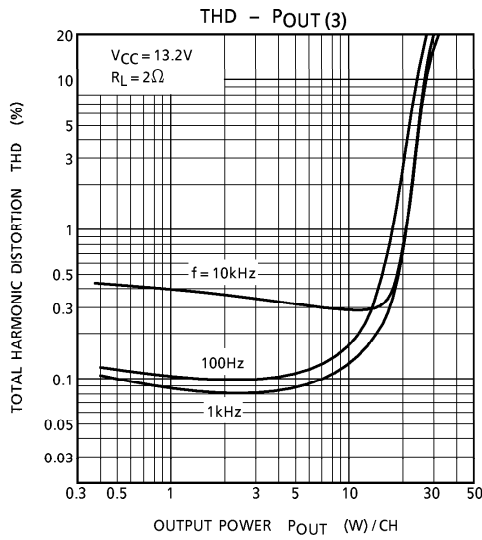
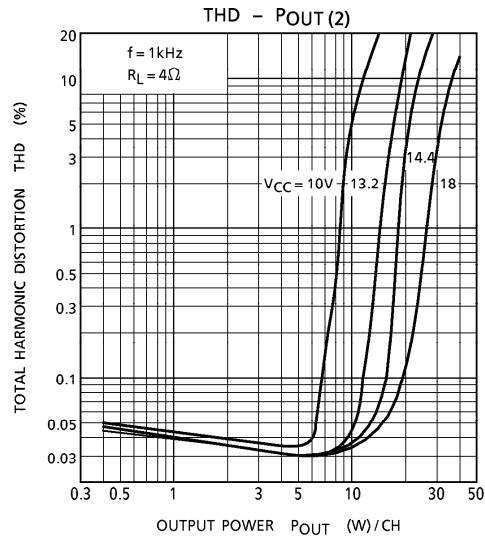
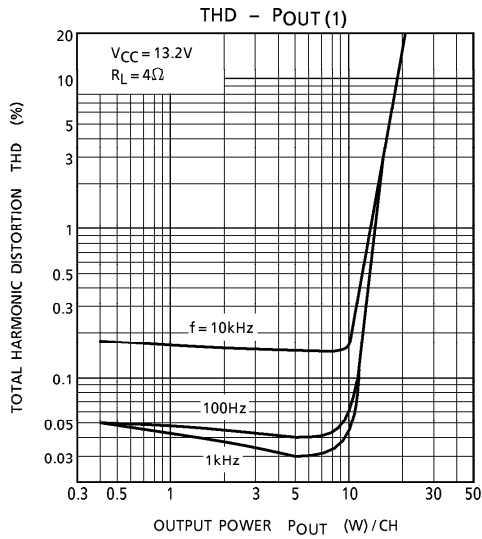

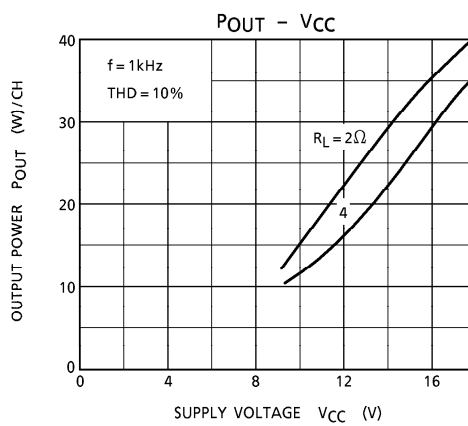
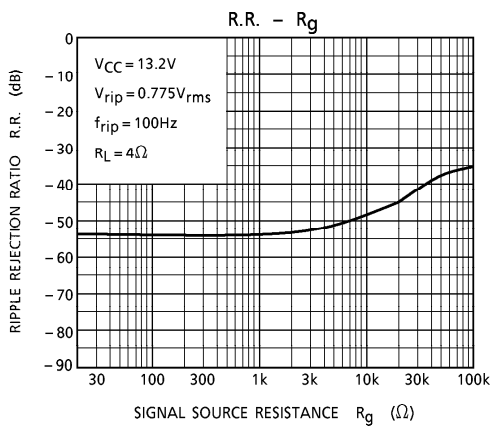
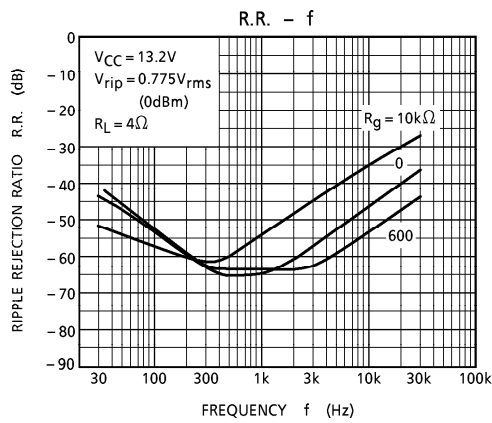
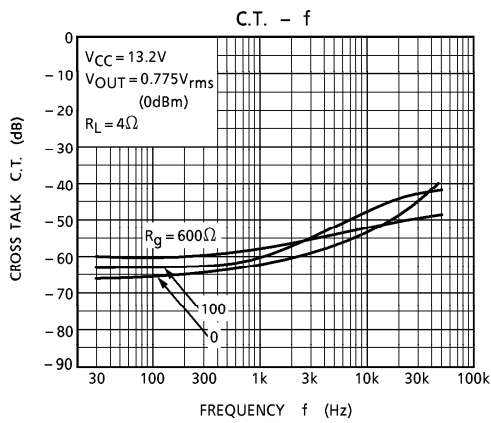
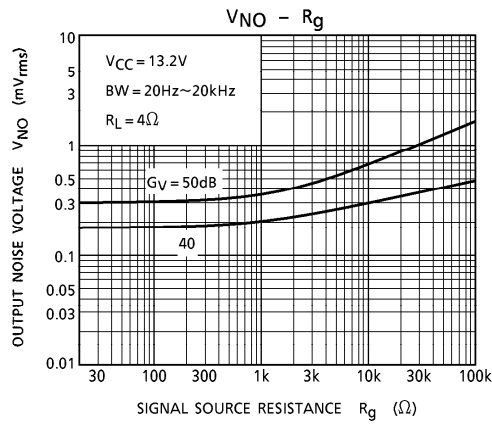
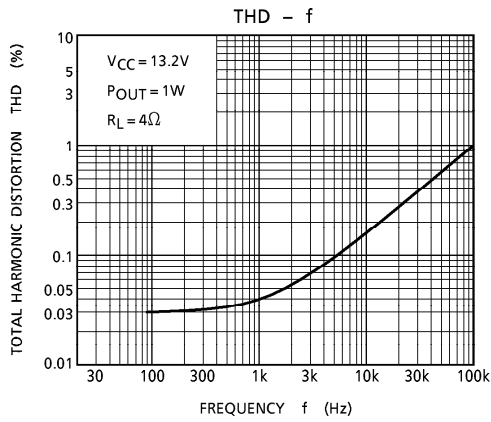

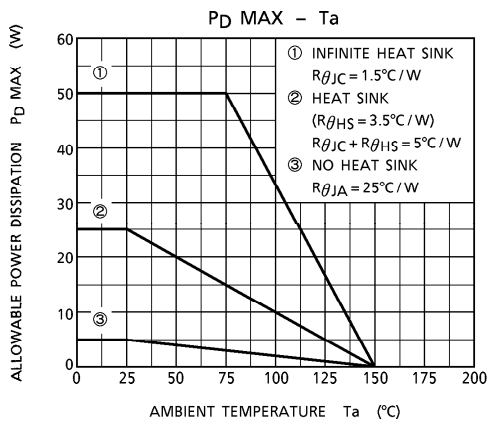
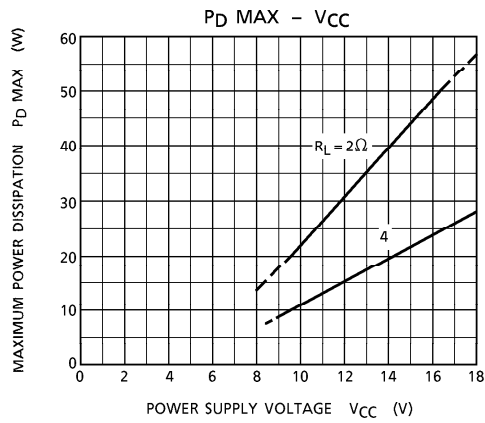
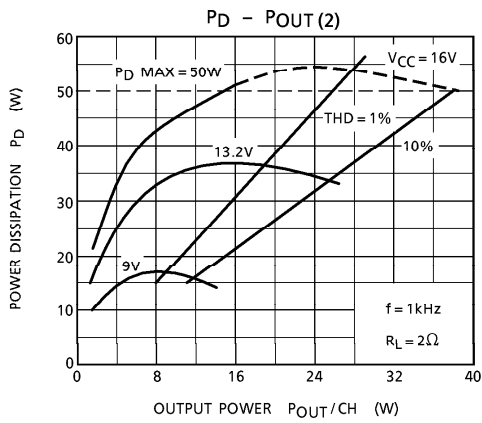
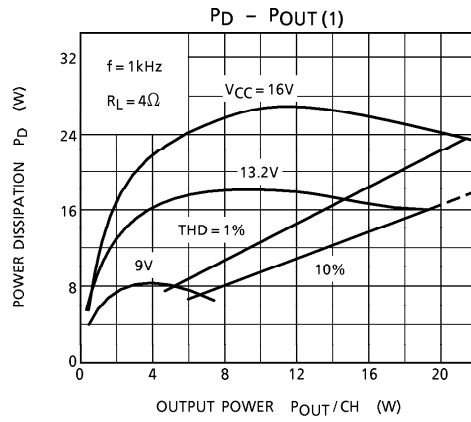
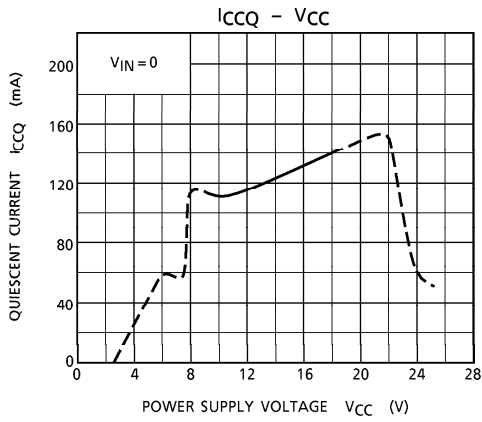

OUTLINE DRAWING
HZIP17-P-2.00

Unit : mm

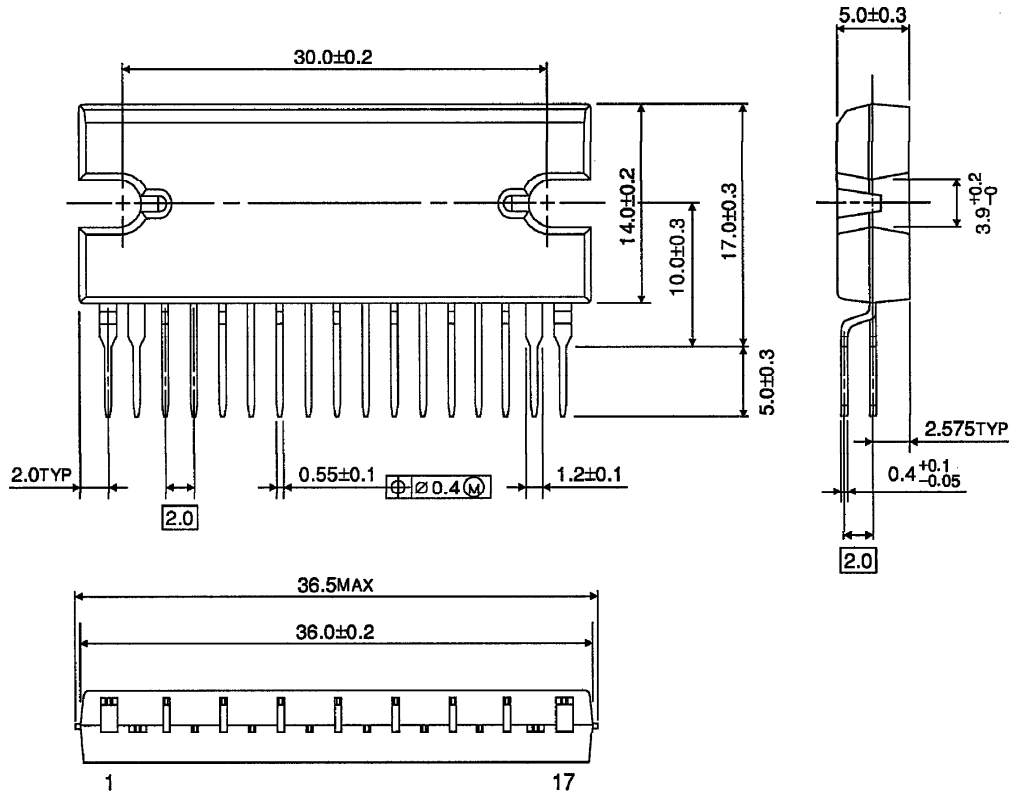

Weight : 9.8g (Typ.)

TA8221AH - 12

1996-09-09

TOSHIBA CORPORATION

OUTLINE DRAWING
HSIP17-P-2.00

Unit : mm

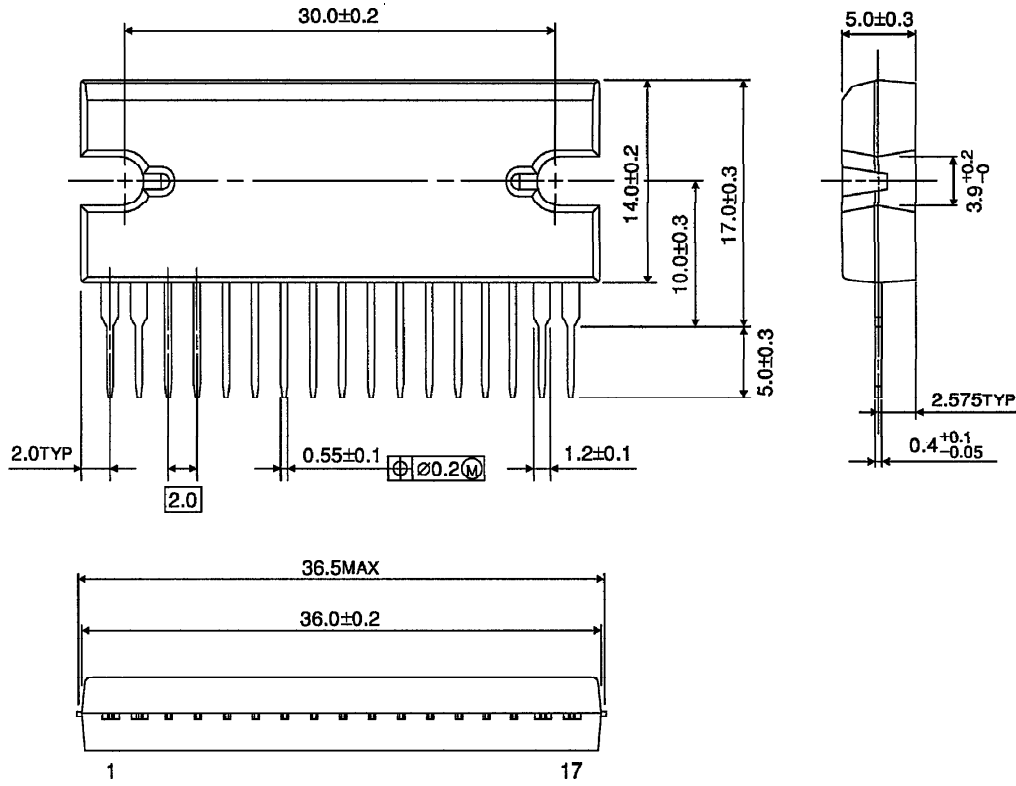

Weight : 9.8g (Typ.)

TA8221AH - 13*
1996-09-02
TOSHIBA CORPORATION