

TOSHIBA BIPOLAR LINEAR INTEGRATED CIRCUIT SILICON MONOLITHIC

# TA8473F, TA8473FN

## FAN MOTOR DRIVER IC

The TA8473F and TA8473FN are fan motor driver ICs. The output current is 0.4 A (AVE.) and all functions needed for fan motor driving have been incorporated into 1 chip. These are provided with the function to automatically change the motor speed by detecting ambient temperature through the externally mounted thermistor. Furthermore, the TA8473F and TA8473FN are provided with the noise reduction terminal, the FG terminal to output pulses proportional to the motor speed and the RD terminal to detect the motor status.

### FEATURES

- Built-in automatic self rotation recovery circuit after release of motor locking.
- Thermal shutdown circuit incorporated.
- Operating voltage : 6~13.8 V
- 2 kind of speed of full-speed and half-speed are variable according to ambient temperature.
- Speed change point temperature is externally settable.

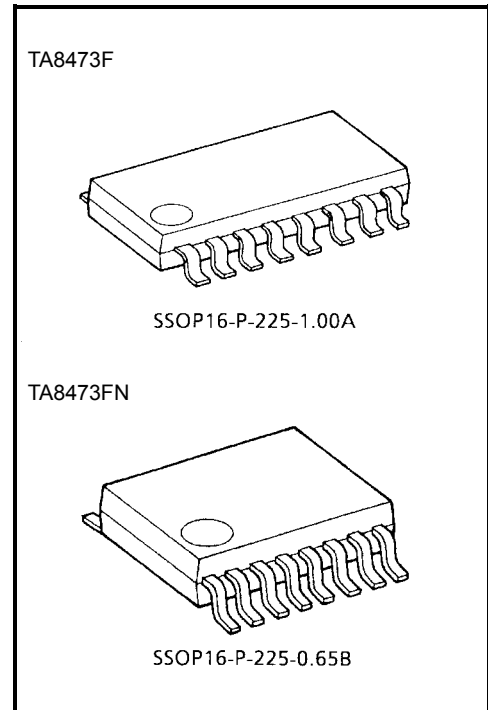

Weight:  
SSOP16-P-225-1.00A: 0.14g (Typ.)  
SSOP16-P-225-0.65B: 0.07g (Typ.)



## HALF-SPEED SYSTEM

To lower the motor speed, TA8473F and TA8473FN set the off-time during the output timings (Fig.1). Starting the multivibrator (MMV) enables the off-time. The off-time is set by the time constant of capacitor Ch connected to the HS terminal and IC internal resistor Rh. A thermistor can also be used to control off-time depending on the temperature.

### (1) Determining Ch

The MMV operation can be monitored through the HS terminal. About 100 kΩ Rh is connected between VCC and HS, generating a transient with the external Ch. The maximum peak level value is set to about 5 V and the bottom level to about 1 V.

The off-time is determined as follows :

$$T = Ch \cdot Rh \times \lambda \log \frac{V_{CC} - 1}{5 - 1}$$

For example, at Ch = 0.1 μF, Rh = 100 kΩ, and VCC = 12 V, off-time is about 4.4 ms. Since Rh is an internal resistor, a fluctuation of ±30% is permitted. The temperature characteristic is 0.5% / °C.

### (2) Determining off-time

If approximately the same off-time (×1~1.3) is set for the on timing when the motor is running at full speed, a number of rotations decreases to about half. As the coefficient depends on the motor, determine the off-time value by experimenting.

The number of rotations can be set to any value. However, if the value is too low, the motor can be started but not run stably.

### (3) Detecting temperature and controlling rotations

TA8473F and TA8473FN compare the TH terminal thermistor and the value of the resistor externally connected to the Rref terminal, and alters the off-time. Changes in off-time can be made by altering the peak operation level of MMV. That is, TA8473F and TA8473FN internally apply a reference current of 100 μA to the Rref terminal and generate at the TH terminal a reference voltage of 1 V at Rref = 10 kΩ. The peak level of MMV is controlled using the difference between the current at the TH terminal determined using the thermistor resistance, and another internal reference current.

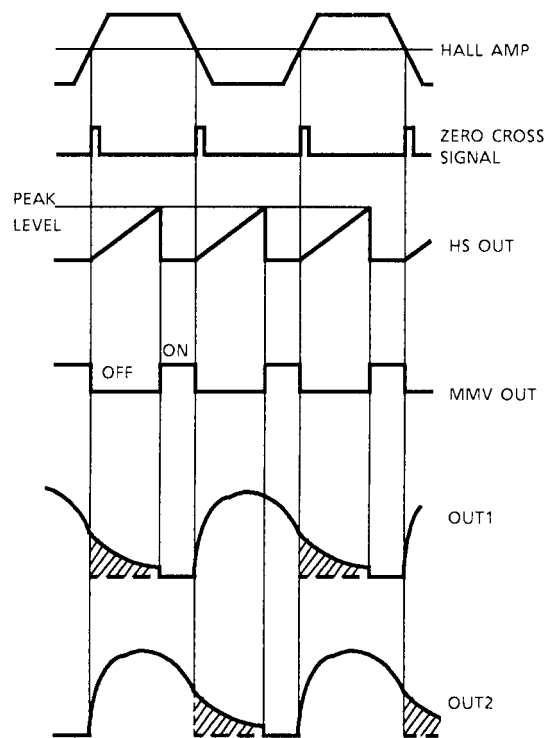

Fig. 1

The peak level can be represented as follows :

$$V_{\text{peak}} = 5 - 240 \text{ k}\Omega (1_{\text{ref1}} \times R_{\text{ref}} / R_{\text{VR}} - 1_{\text{ref2}})$$

Here,  $1_{\text{ref1}} = 1_{\text{ref2}} = 100 \text{ }\mu\text{A Typ.}$

$$R_{\text{VR}} = R_{\text{TH}} + R_{\text{a}}$$

In addition, only positive values within parentheses ( ) are valid. The value of  $V_{\text{peak}}$  is between 1 V and 5 V.

The thermistor resistance,  $R_{\text{TH}}$ , is generally shown as follows :

$$R_{\text{TH}} (T_{\text{a}}) = R_{\text{o}} \times \text{EXP} \cdot B (1 / T_{\text{a}} - 1 / T_{\text{o}})$$

$R_{\text{o}}$  : Resistance ( $\Omega$ ) when reference temperature  $T_{\text{o}}$  (normally,  $25^{\circ}\text{C} = 298\text{K}$ )

$T_{\text{a}}$  : Ambient temperature (K)

$B$  : Characteristic temperature (K)

As the above equation shows, the thermistor has a negative temperature characteristic for ambient temperature,  $T_{\text{a}}$ . The resistance drops at high temperature. Using this characteristic, lowering the  $V_{\text{peak}}$  value at high temperature runs the motor at full speed ; raising the value at low temperature reduces the number of fan rotations with the maximum off-time.

The number of rotations begins to increase from the minimum when  $R_{\text{VR}} \leq R_{\text{ref}}$ , reaching the motor's full speed when  $R_{\text{VR}}$  is about  $0.85 \times R_{\text{ref}}$ .

### <Example 1>

When a thermistor with characteristics  $B = 4200 \text{ K}$  and  $R_{\text{o}} = 10 \text{ k}\Omega$  (at  $T_{\text{a}} = 25^{\circ}\text{C}$ ) is used without other resistors, the motor speed slows down at  $25^{\circ}\text{C}$  or lower if  $R_{\text{ref}} = 10 \text{ k}\Omega$ , and is at full speed at  $30^{\circ}\text{C}$  or higher if  $R_{\text{TH}} = 8.5 \text{ k}\Omega$ .

### <Example 2>

When resistors are connected in series to the thermistor and  $R_{\text{VR}}$  composite resistance is obtained, the resistance change ratio drops :

$$\frac{\delta R_{\text{VR}} / R_{\text{VR}}}{\delta R_{\text{TH}} / R_{\text{TH}}} < 1$$

Therefore, there is a wide range for the number of the rotations.

## (4) Miscellaneous

The thermistor should be connected to where the temperature is detected. Consequently, the thermistor may be located away from the IC. In this case, if the wire from the thermistor is accidentally disconnected, the TH terminal opens and rotation control switches to the low-speed condition.

To deal with this situation, TA8473F and TA8473FN are designed so that when the thermistor wire is disconnected, the motor runs at full speed.

**FG AND RD OUTPUTS**

Both the FG and RD outputs are the open collector outputs.

The FG output is pulse proportional to the number of revolutions (the cycle is the same as OUT B) and the RD output is at the GND level (actually, at  $V_{sat}$  (RD) level) when the motor is being driven and the RD output at the potential level that is to be applied to the RD terminal as shown in Fig.2 is output when the motor is kept restrained.

**AUTOMATIC SELF ROTATION RECOVERY CIRCUIT**

If the rotation of the fan motor is forced to stop by any physical power, the driving coil may be burnt as inducing voltage caused when the motor is running disappears and large current flows to the driving coil.

Therefore, it becomes necessary to provide the fan motor with a circuit to prevent the driving coil from being burned by detecting the forced stop of the motor rotation from the outside by some method and a circuit to automatically rotate the motor when it is released from the restraint.

The TA8473F and TA8473FN are ICs that have cleared the above problems by the burning preventive automatic return circuit.

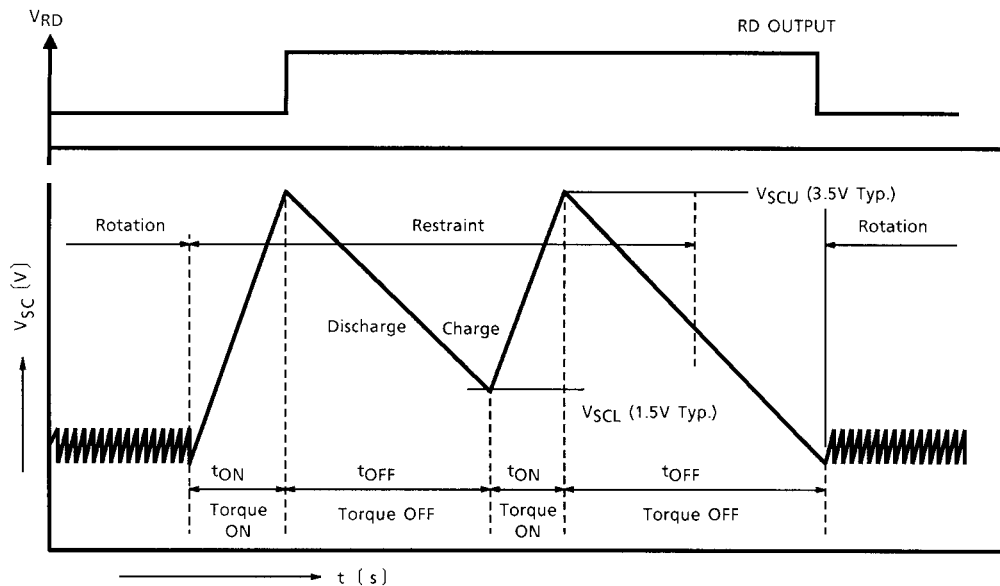

**Fig. 2**

This operation is shown in Fig.2.

The capacitor CSC connected to the CSC terminal is charged by the charging current ISL and its potential rises as shown below :

$$V = \frac{1}{C_{SC}} \int I_{SL} dt$$

When the motor is rotating, it is charged and discharged repeatedly by trigger pulse but if the motor rotation is physically restrained, CSC discharge by trigger pulse is stopped and the potential further increases. During this period, current flows continuously to the motor. If VSC (OSC potential) reaches VSCU, discharge starts slowly and at the same time, the output is turned OFF to cur off current flowing to the motor. When the VSC potential reaches VSCL, the output is turned ON to allow current flow to the motor and torque is generated.

As long as the motor rotation is kept restrained, this operation is repeated and the output is turned ON / OFF at a ratio of nearly 1 : 5.

By this operation, the motor is heated and cooled and its temperature rise can be suppressed to a certain level. If the motor is released from the above restraint, the motor is started to run again by the generated torque and is continuously rotated by the generated trigger pulse.

## FUNCTION

MODE	INPUT		OUTPUT	
	H + (15)	H - (14)	OUT1 (3)	OUT2 (6)
MODE 1	H	L	ON	OFF
MODE 2	L	H	OFF	ON

## MAXIMUM RATINGS (Ta = 25°C)

CHARACTERISTIC		SYMBOL	RATING	UNIT	
Output Terminal Breakdown Voltage		V <sub>CER</sub>	30	V	
Operating Supply Voltage		V <sub>CC (opr.)</sub>	13.8	V	
Output Current	AVE.	I <sub>O (AVE.)</sub>	0.4	A	
	PEAK	I <sub>O (PEAK)</sub>	1.2 (Note 1)		
RD Output Current		I <sub>RD</sub>	10	mA	
FG Output Current		I <sub>FG</sub>	10	mA	
Hall Input Voltage		V <sub>HM</sub>	300 (Note 2)	mV	
Power Dissipation		P <sub>D</sub>	F	800 (Note 3)	mW
			FN	735 (Note 3)	
Operating Temperature		T <sub>opr</sub>	-30~85	°C	
Storage Temperature		T <sub>stg</sub>	-55~150	°C	

Note 1: t = 0.1 s

Note 2: T<sub>j</sub> = -25~150°C

Note 3: This value is obtained by 50 × 50 × 1.6 mm PCB mounting occupied in excess of 40% of copper area.

## ELECTRICAL CHARACTERISTICS (Ta = 25°C, V<sub>CC</sub> = 12 V)

CHARACTERISTIC		SYMBOL	TEST CIR-CUIT	TEST CONDITION	MIN	TYP.	MAX	UNIT
Supply Current		I <sub>CC</sub>	—	V <sub>CC</sub> = 12 V, OUT1 "ON"	—	7.0	12.0	mA
Output Saturation Voltage		V <sub>sat1</sub>	—	I <sub>O</sub> = 0.2 A, T <sub>j</sub> = 25°C	—	0.9	1.1	V
		V <sub>sat2</sub>	—	I <sub>O</sub> = 1.0 A, T <sub>j</sub> = 25°C	—	1.3	1.8	
Automatic Self Rotation Recovery Circuit	Discharge Current	I <sub>SL</sub>	—	—	0.2	0.5	1.0	μA
	Charge Current	I <sub>SU</sub>	—	—	1.4	2.0	3.0	μA
	Discharge Voltage	V <sub>SL</sub>	—	—	—	1.5	—	V
	Charge Voltage	V <sub>SU</sub>	—	—	—	4	—	V
	Time Constant	T <sub>SC</sub>	—	C = 0.22 μF, ON time	—	0.25	—	s
	Duty	DR	—	—	3	5	8	
Hall Amp.	Hall Input Voltage	V <sub>HM</sub>	—	—	±10	±50	±300	mV
	Hysterisis	ΔV <sub>H</sub>	—	—	—	8	—	mV
	Offset Voltage	V <sub>HO</sub>	—	—	—	0	—	mV
	Opereating DC Potential	CMR	—	—	0	—	V <sub>CC</sub> -2	V
	Input Bias Current	I <sub>IN</sub>	—	—	—	1	3.0	μA
RD Output Saturation Voltage		V <sub>sat (RD)</sub>	—	I <sub>RD</sub> = 5 mA	—	0.2	0.4	V
FG Output Saturation Voltage		V <sub>sat (FG)</sub>	—	I <sub>FG</sub> = 5 mA	—	0.2	0.4	V
Variable Speed	Terminal Voltage	V <sub>TH</sub>	—	R <sub>TH</sub> = 10 kΩ	0.7	1	1.5	V
	Full Speed	R <sub>TH (FS)</sub>	—	R <sub>ref</sub> = 10 kΩ	—	6	—	kΩ
	Half Speed	R <sub>TH (HS)</sub>	—	R <sub>ref</sub> = 10 kΩ	—	10	—	kΩ
Termal Shutdown Operating Temperature		T <sub>SD</sub>	—	—	150	—	—	°C

## APPLICATION CIRCUIT

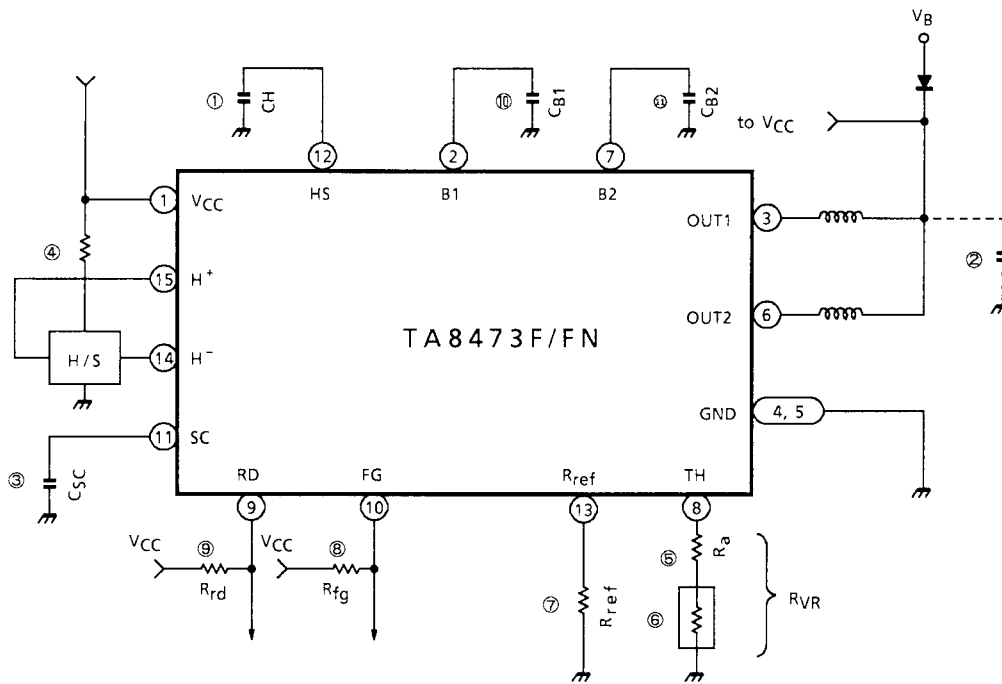

### <External parts>

- |      |                  |  |
|------|------------------|--|
| (1)  | CH               | The Half-speed is decided by CH and RH                                     |
| (2)  | T.B.D            | Insert this if a noise comes in from the Power Supply.                     |
| (3)  | C <sub>SC</sub>  | 0.22 μF Capacitor for burning protection circuit.                          |
| (4)  | 2 kΩ             | Hall sensor bias resistor.   |
| (5)  | R <sub>a</sub>   | T.B.D Resistor for adjusting temperature at which the motor speed changes. |
| (6)  |                  | Thermistor   |
| (7)  | R <sub>ref</sub> | (10 kΩ) Reference resistor   |
| (8)  | R <sub>fg</sub>  | 10 kΩ Pull-up resistor   |
| (9)  | R <sub>rd</sub>  | 10 kΩ Pull-up resistor   |
| (10) | C <sub>B1</sub>  | (0.01 μF) Capacitor for noise reduction                                    |
| (11) | C <sub>B2</sub>  | (0.01 μF) Capacitor for noise reduction                                    |

Note: Utmost care is necessary in the design of the output line, V<sub>CC</sub> and GND line since IC may be destroyed due to short-circuit between outputs, air contamination fault, or fault by improper grounding.



**PACKAGE DIMENSIONS**

SSOP16-P-225-1.00A

Unit : mm

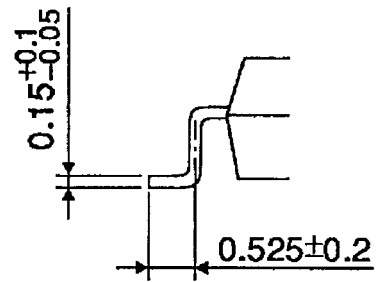
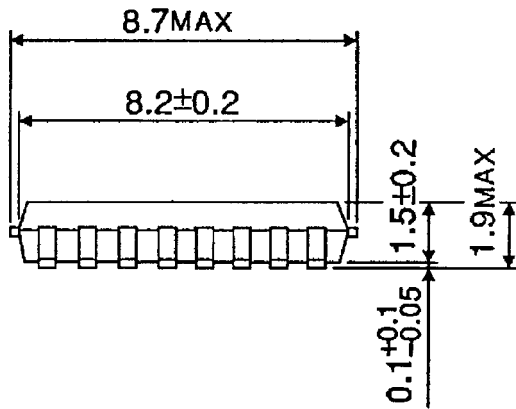
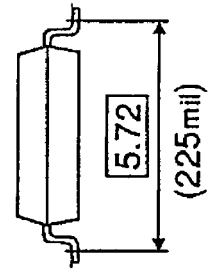
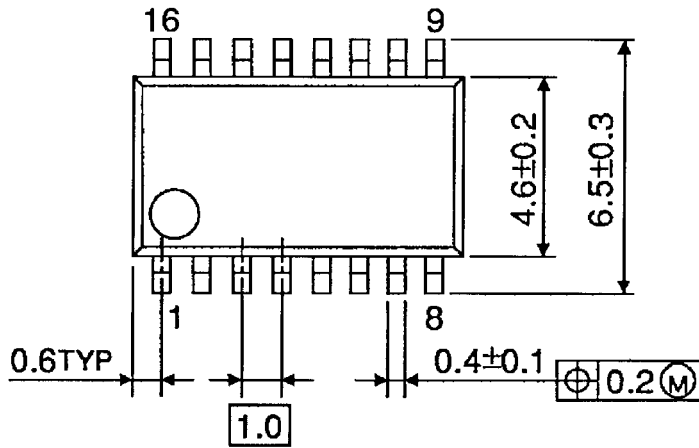

Weight : 0.14 g (Typ.)

**PACKAGE DIMENSIONS**

SSOP16-P-225-0.65B

Unit : mm

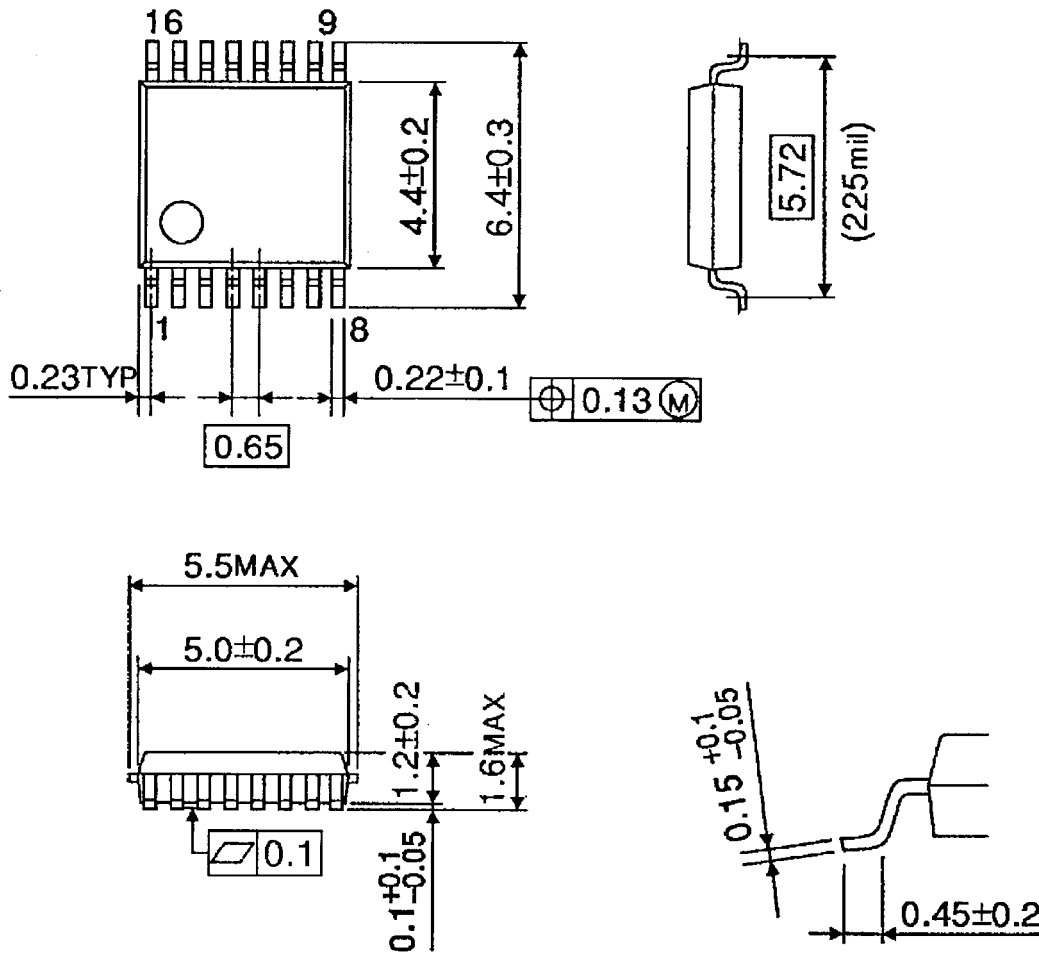

Weight : 0.07 g (Typ.)

**RESTRICTIONS ON PRODUCT USE**

000707EBA

- TOSHIBA is continually working to improve the quality and reliability of its products. Nevertheless, semiconductor devices in general can malfunction or fail due to their inherent electrical sensitivity and vulnerability to physical stress. It is the responsibility of the buyer, when utilizing TOSHIBA products, to comply with the standards of safety in making a safe design for the entire system, and to avoid situations in which a malfunction or failure of such TOSHIBA products could cause loss of human life, bodily injury or damage to property.  
In developing your designs, please ensure that TOSHIBA products are used within specified operating ranges as set forth in the most recent TOSHIBA products specifications. Also, please keep in mind the precautions and conditions set forth in the "Handling Guide for Semiconductor Devices," or "TOSHIBA Semiconductor Reliability Handbook" etc..
- The TOSHIBA products listed in this document are intended for usage in general electronics applications (computer, personal equipment, office equipment, measuring equipment, industrial robotics, domestic appliances, etc.). These TOSHIBA products are neither intended nor warranted for usage in equipment that requires extraordinarily high quality and/or reliability or a malfunction or failure of which may cause loss of human life or bodily injury ("Unintended Usage"). Unintended Usage include atomic energy control instruments, airplane or spaceship instruments, transportation instruments, traffic signal instruments, combustion control instruments, medical instruments, all types of safety devices, etc.. Unintended Usage of TOSHIBA products listed in this document shall be made at the customer's own risk.
- The products described in this document are subject to the foreign exchange and foreign trade laws.
- The information contained herein is presented only as a guide for the applications of our products. No responsibility is assumed by TOSHIBA CORPORATION for any infringements of intellectual property or other rights of the third parties which may result from its use. No license is granted by implication or otherwise under any intellectual property or other rights of TOSHIBA CORPORATION or others.
- The information contained herein is subject to change without notice.