

TC9244P

LSI FOR REMOTE CONTROL RECEIVING

The TC9244P is an LSI for infrared Remote Control receiving. It is used for remote control of devices such as audio system, TVs, VTRs, CD players.

Remote control systems are easily constructed using TC9244P in combination with transmitting LSIs TC9243P and TC9243F.

FEATURES

- Basic function : 9
 - Hold pulse function : 7
 - Cyclic pulse function : 2
- 3 functions out of 7 hold pulse functions are shift key outputs and can be output in parallel with other outputs corresponding to double-pushed signals sent from sending side.
- 1 function out of 2 cyclic pulse functions can be control outputs using an external key in addition to control by remote control signal.
- 8bit system codes are detected. System codes permitting signal receiving can be set up to 4 bits. Interference with other equipment can be thus prevented.

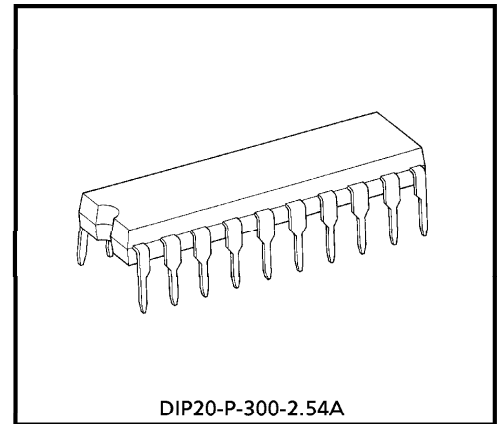

Weight : 1.4g (Typ.)

PIN CONNECTION (TOP VIEW)

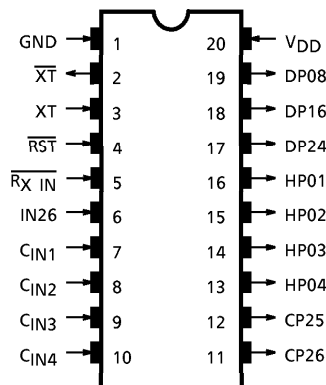

BLOCK DIAGRAM

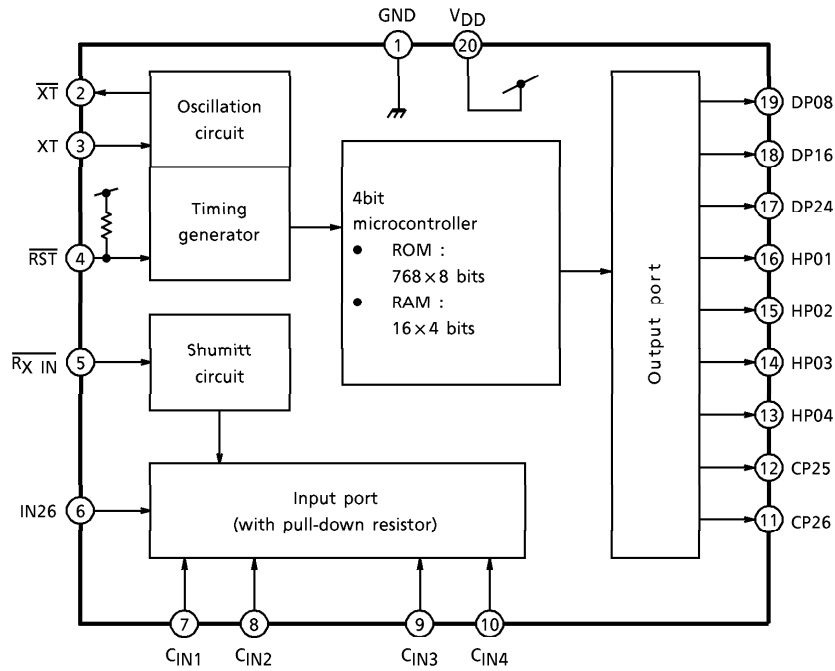

PIN FUNCTION

PIN No.	SYMBOL	PIN NAME	FUNCTION AND OPERATION	
1	GND	Power supply terminal	Applies power supply voltage. ($V_{DD} = 5.0V$, Typ.)	
20	V_{DD}			
2	\overline{XT}	Oscillator terminal	Ceramic oscillator output and input amplifier circuit and feedback resistor are built in.	
3	XT			
4	\overline{RST}	Reset input	When set to "L" level, initializes internal states. pull-up resistor are built in.	
5	$\overline{RX IN}$	Remote control signal input	Input remote control signal whose sub-carrier signal is removed.	
6	IN26	Cyclic input	Inverts corresponding output (CP26) each time "H" level is input. Pull-down resistors are built in.	
7~10	$C_{IN1} \sim C_{IN4}$	Code input	Inputs system code which enables receiving. Pull-down resistors are built in.	
11, 12	CP26, CP25	Cyclic output	Inverted by corresponding remote control signal and key input. "L" level when power is turned on. (reset)	
13~16 17~19	HP04~HP01 DP24, 16, 08	Hold output	Remains at "H" level during remote control signal input.	

OUTPUT FORMAT

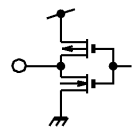

OPERATIONS

1. Setting receive-enable system code

Transmitting LSIs TC9243P and TC9243F support an 8bit system code transmitting format to prevent interference with other machines.

This code makes each machine unique and thus prevents interference.

With TC9244P, the lower 4 bits of the 8bit system code used to enable receive can be set.

The upper 4 bits are fixed to "1000". (Setting value range : "80"~"8F" HEX.)

Once this receive-enabling system code is set, a match between the system code of the remote control input signal and the set system code enables reception of the subsequent key data code.

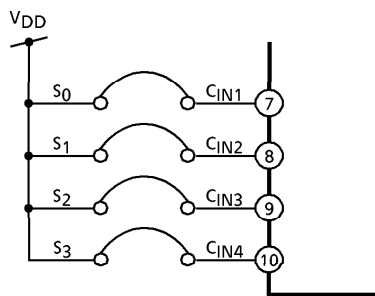

To set the receive-enabling system code, connect pins C1N1~4 to VDD using jumpers.

The jumpers correspond to system code bits 0~3 (S0~S3).

Connecting the pins to VDD using jumpers sets the corresponding bits to 1.

2. Receive signal check

The transmitting LSIs TC9243P and TC9243F support transmission of a check code in one-shot waveforms in order to prevent malfunctioning due to data read errors.

As the check code, the same system code is sent again ; after the key data code, the inverted key data code is sent.

Leader pulse	System code								System code								Key data code								$\overline{\text{Key data code}}$							
	S ₀	S ₁	S ₂	S ₃	S ₄	S ₅	S ₆	S ₇	S ₀	S ₁	S ₂	S ₃	S ₄	S ₅	S ₆	S ₇	D ₀	D ₁	D ₂	D ₃	D ₄	D ₅	D ₆	D ₇	$\overline{D_0}$	$\overline{D_1}$	$\overline{D_2}$	$\overline{D_3}$	$\overline{D_4}$	$\overline{D_5}$	$\overline{D_6}$	$\overline{D_7}$

TC9244P decodes all data. The code is sent twice. TC9244P determines that the data are valid only when codes in both transmissions match.

3. HP, DP and CP output pulses

3-1. HP01~HP04, DP08, DP16, DP24 (Hold pulse)

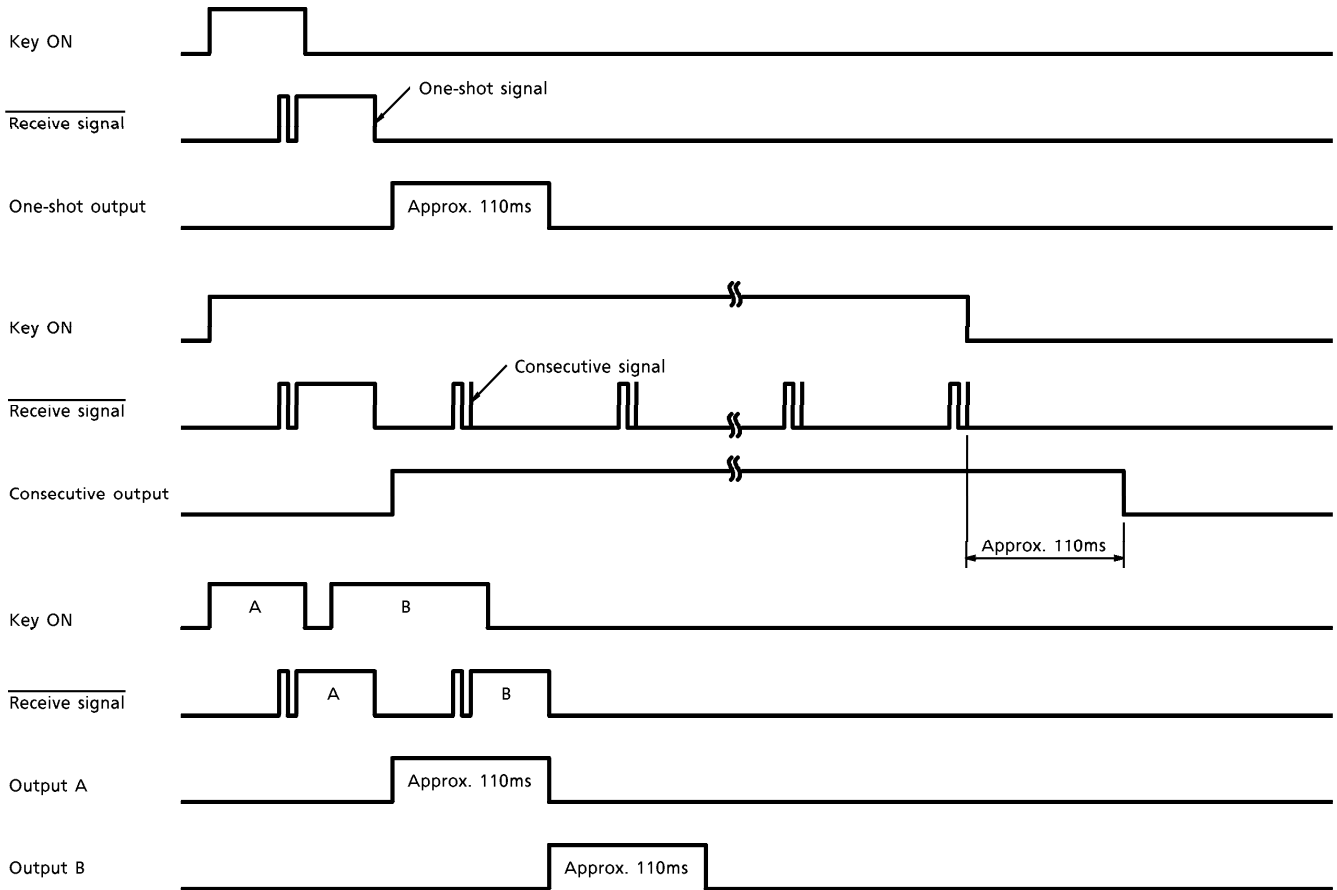

When the initial one-shot system code and the receive signal are checked and the data are valid, the hold pulse is switched to "H" level.

If the receive signal is only a one-shot signal, the output switches to "L" level after approximately 110ms.

If the key is held down after the one-shot signal is output and signals are input consecutively, the output stays at "H" level.

When the key is released and the consecutive signal input stops, key release is determined after 110ms elapses after the last consecutive signal input.

The output is switched to "L" level.

DP08, DP16, DP24 are used for outputting shift pulses.

These are set to "H" level in parallel to other output in response to a signal indicating that two keys are pressed simultaneously sent by the transmitter.

This type of output is optimal for tape deck RECORD-PLAY, RECORD-PAUSE and RECORD-REVERSE output.

3-2. CP25 and CP26 (Cyclic pulses)

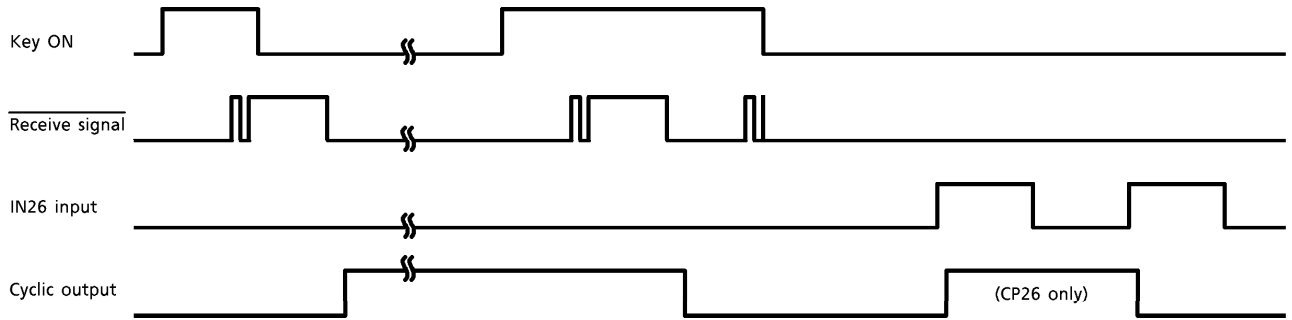

Cyclic pulses are inverted each time a one-shot signal is received.
 Setting pin IN26 to "H" level also inverts CP26.
 Unless output is stabilized within 4ms, cyclic pulse is not valid.
 Thus, an external component used to prevent chatter is not required.
 Cyclic pulse output is optimal for turning power on/off and for muting.

4. Code assignment (Key numbers : TC9243P and TC9243F send key numbers)

KEY NUMBER	KEY DATA CODE								OUTPUT	FUNCTION
	D ₀	D ₁	D ₂	D ₃	D ₄	D ₅	D ₆	D ₇		
K ₀₁	1	0	0	0	0	(*)	(*)	(*)	HP01	Hold
K ₀₂	0	1	0	0	0	(*)	(*)	(*)	HP02	
K ₀₃	1	1	0	0	0	(*)	(*)	(*)	HP03	
K ₀₄	0	0	1	0	0	(*)	(*)	(*)	HP04	
K ₀₈	(*)	(*)	(*)	(*)	(*)	1	0	0	DP08	Hold and Shift
K ₁₆	(*)	(*)	(*)	(*)	(*)	1	1	0	DP16	
K ₂₄	(*)	(*)	(*)	(*)	(*)	1	0	1	DP32	
K ₂₅	1	0	0	1	1	(*)	(*)	(*)	CP25	Cyclic
K ₂₆	0	1	0	1	1	(*)	(*)	(*)	CP26	

(*) Don't care (Corresponding output changes regardless of data)

MAXIMUM RATING (Ta = 25°C)

CHARACTERISTIC	SYMBOL	RATING	UNIT
Supply Voltage	V _{DD}	-0.3~6.0	V
Input Voltage	V _{IN}	GND - 0.3~V _{DD} + 0.3	V
Power Dissipation	P _D	350	mW
Operating Temperature	T _{opr}	-40~85	°C
Storage Temperature	T _{stg}	-65~150	°C

ELECTRICAL CHARACTERISTICS

Recommended operating conditions (Unless otherwise specified, V_{DD} = 5.0V, Ta = 25°C)

CHARACTERISTIC	SYMBOL	TEST CIR-CUIT	TEST CONDITION	MIN.	TYP.	MAX.	UNIT
Operating Supply Voltage	V _{DD}	—	Ta = -40~85°C	4.5	—	5.5	V
Oscillation Frequency	f _{osc}	—	—	400	—	800	kHz
Input Voltage	"H" Level	V _{IH1}	(Except \overline{RST} , $\overline{RX IN}$)	V _{DD} × 0.7	—	V _{DD}	V
	"H" Level	V _{IH2}	(\overline{RST} , $\overline{RX IN}$)	V _{DD} × 0.8	—	V _{DD}	V
	"L" Level	V _{IL1}	(Except \overline{RST} , $\overline{RX IN}$)	0	—	V _{DD} × 0.3	V
	"L" Level	V _{IL2}	(\overline{RST} , $\overline{RX IN}$)	0	—	V _{DD} × 0.2	V

DC Characteristics (Unless otherwise specified, V_{DD} = 5.0V, Ta = 25°C)

CHARACTERISTIC	SYMBOL	TEST CIR-CUIT	TEST CONDITION	MIN.	TYP.	MAX.	UNIT
Operating Supply Current	I _{DD}	—	f _{osc} = 455kHz	—	1.0	3.0	mA
Pull-down Resistor	R _D	—	(IN26, C _{IN})	100	200	400	kΩ
Pull-up Resistor	R _U	—	(\overline{RST})	25	50	100	kΩ
Output Current	"H" Level	I _{OH}	(CP, HP, DP) V _{OH} = 4V	-1.0	-4.0	—	mA
	"L" Level	I _{OL}	(CP, HP, DP) V _{OL} = 1V	1.0	8.0	—	mA
Input Leak Current	I _{LI}	—	V _{IN} = V _{DD} , GND	-1.0	—	1.0	μA

APPLICATION CIRCUIT

1. TC9244P circuit

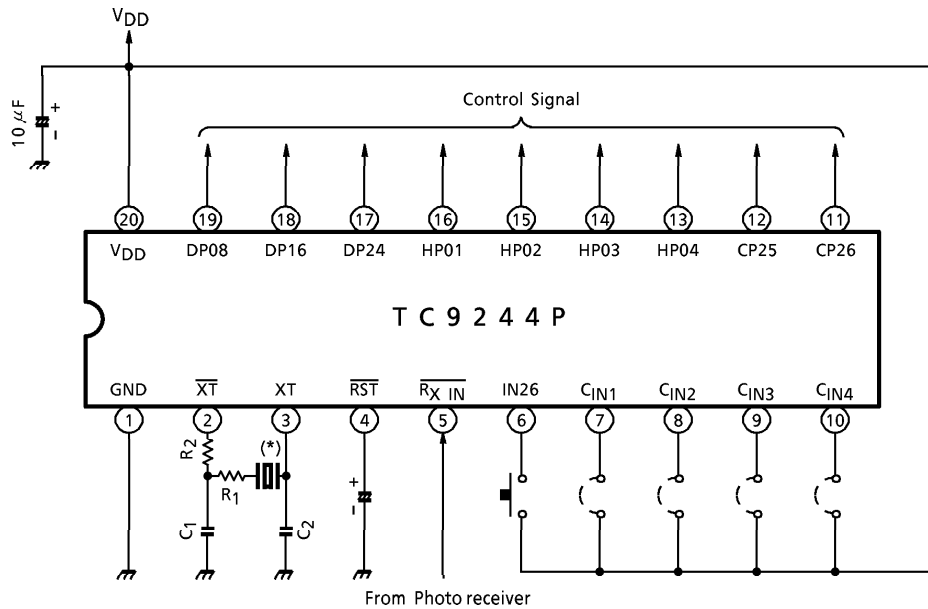

(*) Ceramic oscillator

CSB455E (Murata Seisakusyo) $C_1 = C_2 = 100\text{pF}$, $R_2 = \text{unnecessary}$

In case of influenced by oscillation noise, add resistor R_1 to $10\text{k}\Omega$ MAX.

FCR455K3 (TDK) $C_1 = C_2 = 220\text{pF}$, $R_2 = 4.7\text{k}\Omega$, $R_1 = \text{unnecessary}$

In case of influenced by oscillation noise, add resistor R_2 to large ($>4.7\text{k}\Omega$).
or equivalent

PACKAGE DIMENSIONS
DIP20-P-300-2.54A

Unit : mm

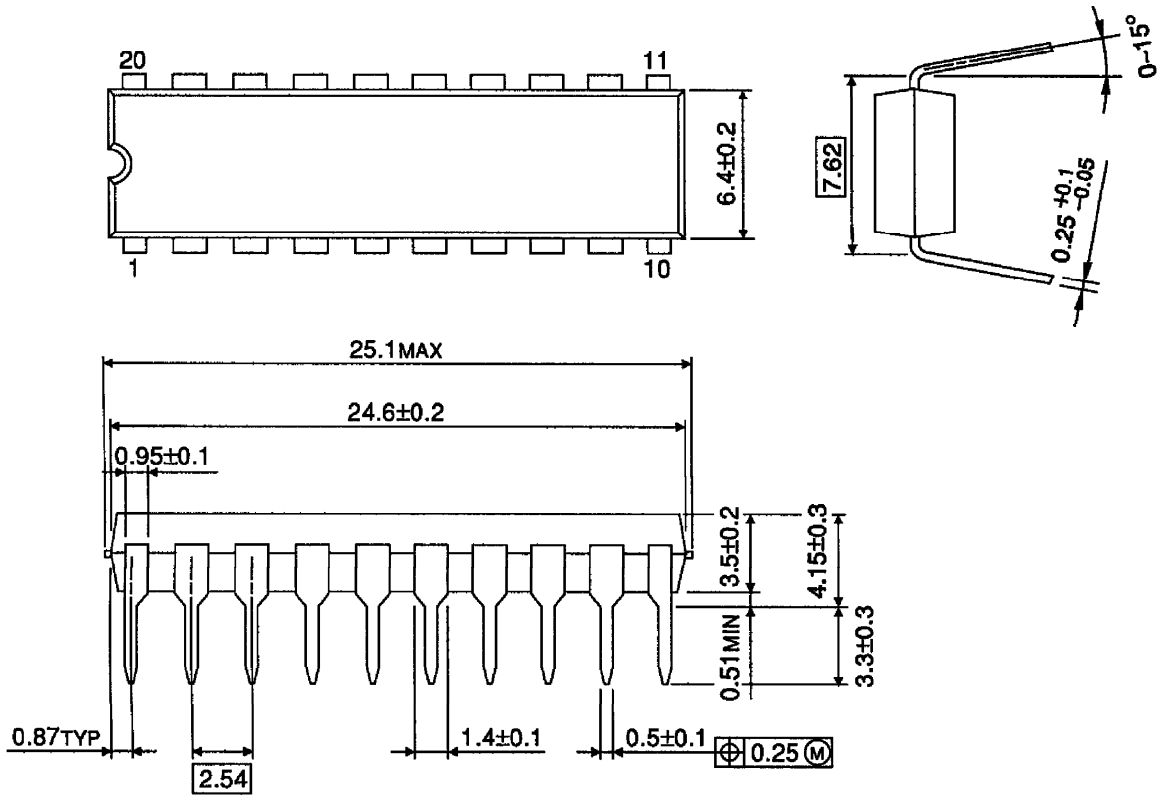

Weight : 1.4g (Typ.)

RESTRICTIONS ON PRODUCT USE

000707EBA

- TOSHIBA is continually working to improve the quality and reliability of its products. Nevertheless, semiconductor devices in general can malfunction or fail due to their inherent electrical sensitivity and vulnerability to physical stress. It is the responsibility of the buyer, when utilizing TOSHIBA products, to comply with the standards of safety in making a safe design for the entire system, and to avoid situations in which a malfunction or failure of such TOSHIBA products could cause loss of human life, bodily injury or damage to property. In developing your designs, please ensure that TOSHIBA products are used within specified operating ranges as set forth in the most recent TOSHIBA products specifications. Also, please keep in mind the precautions and conditions set forth in the "Handling Guide for Semiconductor Devices," or "TOSHIBA Semiconductor Reliability Handbook" etc..
- The TOSHIBA products listed in this document are intended for usage in general electronics applications (computer, personal equipment, office equipment, measuring equipment, industrial robotics, domestic appliances, etc.). These TOSHIBA products are neither intended nor warranted for usage in equipment that requires extraordinarily high quality and/or reliability or a malfunction or failure of which may cause loss of human life or bodily injury ("Unintended Usage"). Unintended Usage include atomic energy control instruments, airplane or spaceship instruments, transportation instruments, traffic signal instruments, combustion control instruments, medical instruments, all types of safety devices, etc.. Unintended Usage of TOSHIBA products listed in this document shall be made at the customer's own risk.
- The products described in this document are subject to the foreign exchange and foreign trade laws.
- The information contained herein is presented only as a guide for the applications of our products. No responsibility is assumed by TOSHIBA CORPORATION for any infringements of intellectual property or other rights of the third parties which may result from its use. No license is granted by implication or otherwise under any intellectual property or other rights of TOSHIBA CORPORATION or others.
- The information contained herein is subject to change without notice.