

TD62445FN

LOW-SATURATION-TYPE SINK DRIVER WITH 4-CIRCUIT OVER-CURRENT DETECTION FUNCTION

The TD62445FN is a sink driver with over-current detector circuits. Each of four circuits can setting the limit current. Using an internal comparator, the TD62445FN detects over-current by comparing the current output through the external resistors as voltage. Over current detection is detected by the ERR terminal which is an open collector, comes on. Construct a system so that the input signal turns off immediately the ERR pin comes on.

FEATURES

- Includes current limiter circuits:
By connecting external resistors, each bit can be set to any limit current value.
- Includes an error detection signal filter pin:
Connecting any capacitor between the LP pin and the GND filters the internal comparator detection signal and outputs this to the ERR pin.
- Over-current monitor detection output:
Includes an ERR pin output to warn when current exceeds the limit. Construct a system so that the input signal turns off immediately the ERR pin comes on (open collector).
- Common input pin (CO-IN (pin 4)) :
Using this pin, the four over-current detector circuits can be forcibly turned off together.
- Low-saturation-type output (open collector):
The voltage drop between the collector and emitter is $V_{OL1} = 0.4 \text{ V (max) @ } I_O = 100 \text{ mA}$.
- Supply voltage : $V_{CC} = 4.5 \text{ to } 5.5$
- Input is TTL compatible.
- Ultra-compact package : SSOP 18 pins (0.65mm pitch)
- Output rating : $V_{CEO} = 30 \text{ V, } I_O = 150 \text{ mA / ch}$
- Packing : Embossed taping only

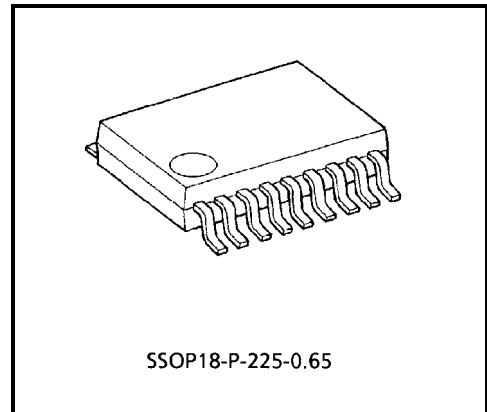

Weight: 0.08 g (Typ.)

PIN CONNECTION (TOP VIEW)

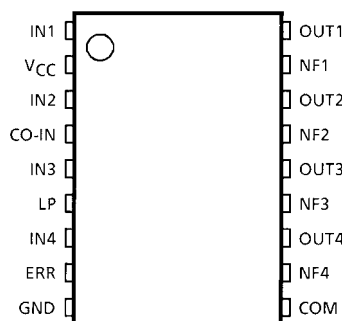

EQUIVALENT CIRCUIT DIAGRAM (Showing One Circuit)

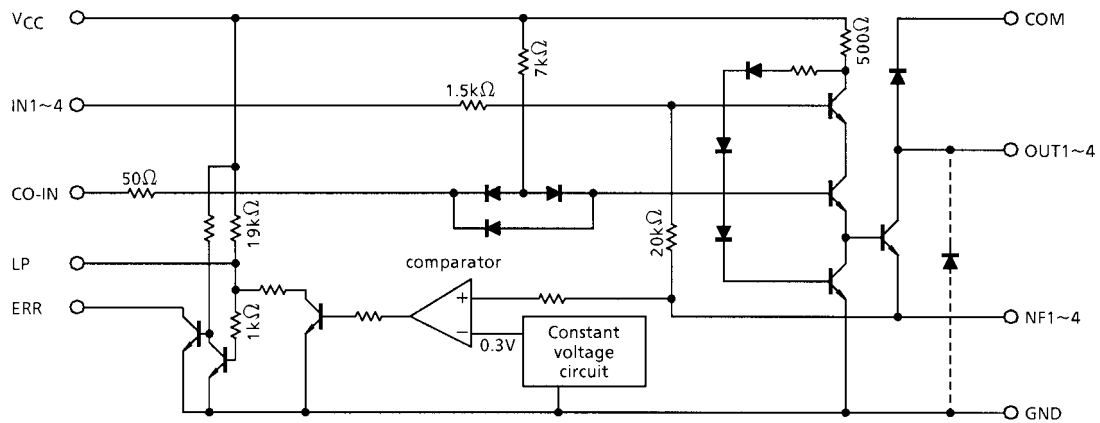

- When the output pins of this IC are connected to the load power supply, over-current may flow to the outputs. While the device includes an over-current detection function, the device is not designed for applications where the output pins and load power supply are intentionally connected.
- Be sure to use the device with the NF1 to 4 and the GND pins connected via resistors or directly connected. Do not use with the NF1 to 4 pins open.
This also applies to unused channels. If the pins are not connected, the operation of the over-current detection function is unstable.
Note that if the NF1 to 4 and GND pins are directly connected, the over-current detection function does not operate.
- A parasitic diode is installed between the GND and output pins. While current is supplied to this diode, other circuit outputs may come on or be otherwise affected. If this phenomenon adversely affects the operation of the device, Toshiba recommends connecting an external diode.

TRUTH TABLE

IN1~4	CO-IN	OUT1~4	VOLTAGE BETWEEN NF1 TO 4 AND GND	ERR
L	H	OFF	0 V	OFF
H	H	ON	0.3 V max	OFF
H	H	ON	0.3 V min	ON
X	L	OFF	0 V	OFF

Note: The above comparator circuit assumes some resistance connected between the NF1 to 4 and GND pins when the circuit operates.

PIN DESCRIPTION

PIN No.	PIN NAME	FUNCTION
1, 3, 5, 7	IN1 to 4	Driver input pins. TTL compatible input level. At high level the output is on; at low level the output is off.
2	V _{CC}	Power supply voltage pin.
4	CO-IN	Output control pin. When high the output operates in accordance with input logic; when low the output is forcibly turned off regardless of the input logic.
6	LP	CR filter circuit pin. Connecting a capacitor to the GND creates a filter for the over-current detection signal from the comparator. When not in use, leave open.
8	ERR	Over-current detection signal output pin. Comes on when excess current is detected. Normally, set to high impedance.
9	GND	GND pin.
10	COM	Clamp diode's common cathode pin.
17, 15, 13, 11	NF1 to 4	Resistor connecting pins for over-current detection setting. By connecting resistors between these pins and GND, the detection level can be set separately for each circuit.
18, 16, 14, 12	OUT1 to 4	Open collector output pins.

MAXIMUM RATINGS

CHARACTERISTICS	SIGNAL	RATING	UNIT
Power Supply Voltage	V _{CC}	7.0	V
COM Pin Voltage	V _{COM}	30.0	V
Output Voltage	V _{CEO}	30.0	V
ERR Pin Output Voltage	V _{ERR}	7.0	V
Output Sink Current	I _{OUT}	0~150	mA
ERR Pin Sink Current	I _{ERR}	10	mA
Input Voltage	V _{IN}	-0.3~V _{CC} + 0.3	V
NF Pin Voltage	V _{IN (NF)}	-0.3~1.0	V
LP Pin Voltage	V _{IN (LP)}	-0.3~V _{CC} + 0.3	V
Clamp Diode Reverse Voltage	V _{r1}	30	V
Clamp Diode Forward Current	I _{f1}	150	mA
Output Parasitic Diode Forward Current	I _{f2}	100	mA
Power Dissipation	P _D (Note)	960	mW
Operating Temperature	T _{opr}	-10~85	°C
Storage Temperature	T _{stg}	-55~150	°C

Note: When the device is mounted on a PCB (with one surface 50 × 50 × 1.6 mm Cu 40% glass epoxy)
When operating at an ambient temperature of 25°C or higher, derate the power dissipation at 7.6 mW / °C.

RECOMMENDED OPERATING CONDITIONS

(Unless otherwise specified, $V_{CC} = 5.0\text{ V}$, $T_a = -10\text{ to }85^\circ\text{C}$)

CHARACTERISTIC	SYMBOL	TEST CONDITION	MIN	TYP.	MAX	UNIT
Power Supply Voltage	V_{CC}	—	4.5	5.0	5.5	V
Output Voltage	V_{CEO}	OUT1~4	0	—	30.0	V
	V_{ERR}	ERR	0	—	$V_{CC} + 0.3$	V
Output Current	I_{OUT}	—	0	—	120	mA
	I_{ERR}	ERR	0	—	8	mA
Input Voltage	V_{IN}	$V_{CC} = 5.0\text{V}$: IN1~4, CO-IN, LP	0	—	V_{CC}	V
Power Dissipation	P_{D1}	$T_a = 60^\circ\text{C}$	—	—	0.69	W / IC
	P_{D2}	$T_a = 85^\circ\text{C}$	—	—	0.50	W / IC

ELECTRICAL CHARACTERISTICS

(Unless otherwise specified, $V_{CC} = 5.0\text{ V} \pm 10\%$, $T_a = -10\text{ to }85^\circ\text{C}$, $V_{IN}(\text{NF}) = \text{GND}$)

CHARACTERISTIC	SYMBOL	TEST CIR-CUIT	TEST CONDITION	MIN	TYP.	MAX	UNIT
Operating Power Supply Voltage	V_{CC}	—	—	4.5	5.0	5.5	V
Output Leakage Current	I_{Oleak1}	1	$V_{CE} = 30\text{ V}$, $V_{IN} = 0\text{ V}$, $T_a = 25^\circ\text{C}$: OUT1~4	0	—	100	μA
	I_{Oleak2}	1	$V_{CE} = 7.0\text{V}$, $V_{NF} = 0\text{ V}$, $T_a = 25^\circ\text{C}$: ERR	0	—	50	
Output Saturation Voltage	V_{OL1}	2	$I_{OUT} = 100\text{ mA}$, $R_{NF} = 0$: OUT1~4	0	0.15	0.40	V
	V_{OL2}	3	$I_{OL} = 10\text{ mA}$: ERR	0	0.20	0.60	
Input Voltage	V_{I+}	3	$V_{ERR} = \text{"L"}$, $T_a = -10\sim 85^\circ\text{C}$: NF1~4	0.25	0.30	0.35	V
	V_{IH}	2	IN1~4, CO-IN	2.50	—	—	
	V_{IL}	1	NF1~4, CO-IN	—	—	0.70	
Input Current	I_{IH}	2	$V_{IN} = 2.5\text{ V}$, $T_a = 25^\circ\text{C}$: IN1~4	—	+0.5	+0.1	mA
	I_{IL1}	1	$V_{IN} = 0.7\text{ V}$, $T_a = 25^\circ\text{C}$: IN1~4	—	+0.1	+0.1	
	I_{IL2}	1	$V_{IN} = 0.7\text{ V}$, $T_a = 25^\circ\text{C}$: CO-IN	—	-1.0	-3.4	
Power Supply Current When Not Operating	I_{CC}	4	$V_{IN} = 0.7\text{ V}$: CO-IN, IN1~4, $T_a = 25^\circ\text{C}$ All outputs off	—	8	10	mA / IC
Power Supply Current When Operating	I_{CCopr}	4	$V_{IN} = 2.5\text{ V}$, $I_{OUT} = 150\text{ mA}$, $T_a = 25^\circ\text{C}$ All outputs on	—	40	70	mA / IC
Clamp Diode Forward Voltage	V_{f1}	5	$I_f = 100\text{ mA}$: OUT1~4 to COM	—	1.20	2.00	V
Clamp Diode Reverse Voltage	V_{r1}	1	$I_r = 100\text{ }\mu\text{A}$: COM to OUT1~4	30	—	—	V
Input / Output Delay Time	$t_{PDIO1} (t_{pLH})$	6	$T_a = 25^\circ\text{C}$, $V_{CE} = 30\text{ V}$, $I_{OUT} = 150\text{ mA}$, $C_L = 10\text{ pF}$: IN1~4 to OUT1~4	—	(Note) 0.25	(Note) 1.25	μs
	$t_{PDIO1} (t_{pHL})$	6		—	(Note) 0.40	(Note) 2.00	

Note: The switching characteristic values indicate the guaranteed design limits.

CHARACTERISTIC	SYMBOL	TEST CIR-CUIT	TEST CONDITION	MIN	TYP.	MAX	UNIT
Input / Output Delay Time	$t_{PDIO2} (t_{pLH})$	7	$T_a = 25^\circ\text{C}$, $V_{ERR} = 5.0\text{ V}$, $I_{OL} = 10\text{ mA}$, $C_L = 10\text{ pF}$, $V_{NF}=0\text{ to }0.4\text{ V}$: NF1~4 to ERR	—	(Note) 0.30	(Note) 1.50	μs
	$t_{PDIO2} (t_{pHL})$	7		—	(Note) 5.00	(Note) 15.0	
	$t_{PDIO3} (t_{pLH})$	6	$T_a = 25^\circ\text{C}$, $V_{CE} = 30\text{ V}$, $I_{OUT} = 150\text{ mA}$, $C_L = 50\text{ pF}$: CO-IN to OUT1~4	—	(Note) 0.25	(Note) 1.25	
	$t_{PDIO3} (t_{pHL})$	6		—	(Note) 0.40	(Note) 2.00	
Output Rise Time	(t_{pLH})	6	$T_a = 25^\circ\text{C}$, $V_{CE} = 30\text{ V}$, $I_{OUT} = 150\text{ mA}$, $C_L = 50\text{ pF}$, 10%~90%: OUT1~4	—	(Note) 0.40	(Note) 1.00	μs
	t_{rERR}	7	$T_a = 25^\circ\text{C}$, $V_{ERR} = 5.0\text{ V}$, $I_{OL} = 10\text{ mA}$, $C_L = 10\text{ pF}$, 10%~90%: ERR	—	(Note) 0.40	(Note) 1.00	
Output Fall Time	t_{fOUT}	6	$T_a=25^\circ\text{C}$, $V_{CE} = 30\text{ V}$, $I_{OUT} = 150\text{ mA}$, $C_L = 50\text{ pF}$, 90%~10%: OUT1~4	—	(Note) 0.10	(Note) 1.00	μs
	t_{fERR}	7	$T_a = 25^\circ\text{C}$, $V_{ERR} = 5.0\text{ V}$, $I_{OL} = 10\text{ mA}$, $C_L = 10\text{ pF}$, 90%~10%: ERR	—	(Note) 0.02	(Note) 1.00	

Note: The switching characteristic values indicate the guaranteed design limits.

TEST CIRCUIT

(1) V_{IL} , $I_{IL1\sim2}$, V_{r1} , V_{CEO} , I_{oleak1} , I_{oleak2}

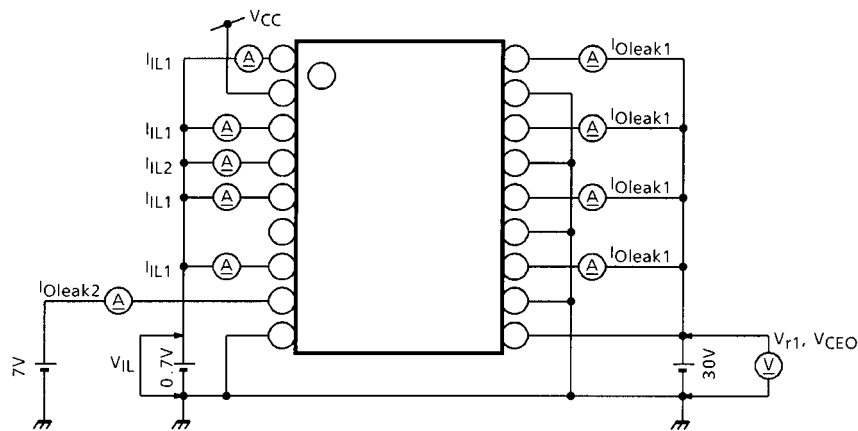

(2) V_{IH} , I_{IH} , V_{OL1}

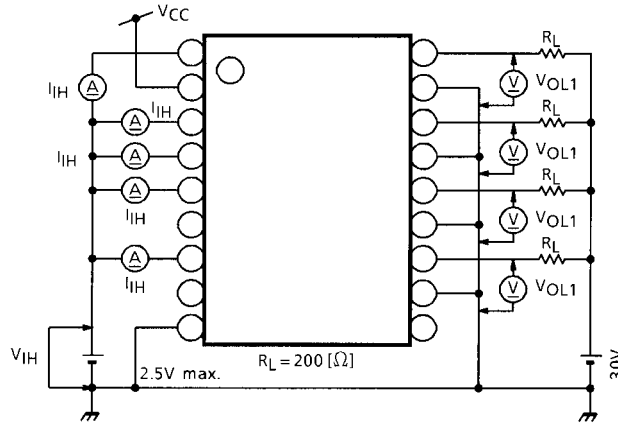

(3) V_{I+} , V_{ERR} , I_{ERR} , V_{OL2}

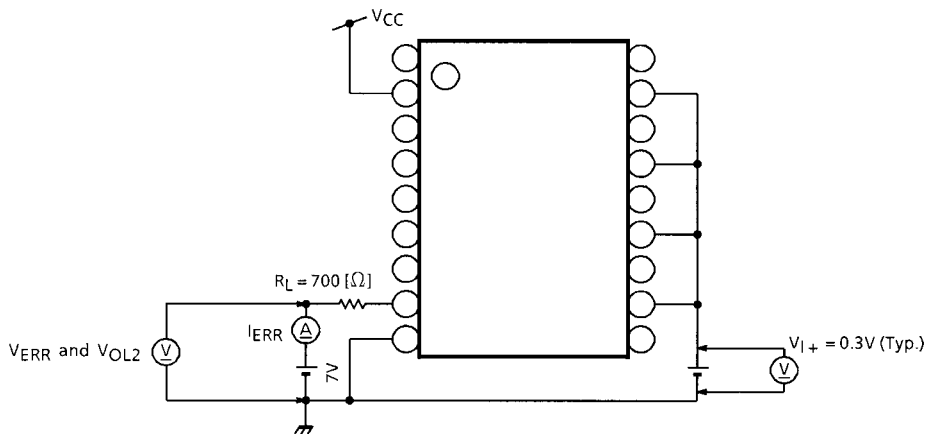

(4) I_{CC} , I_{CCopr}

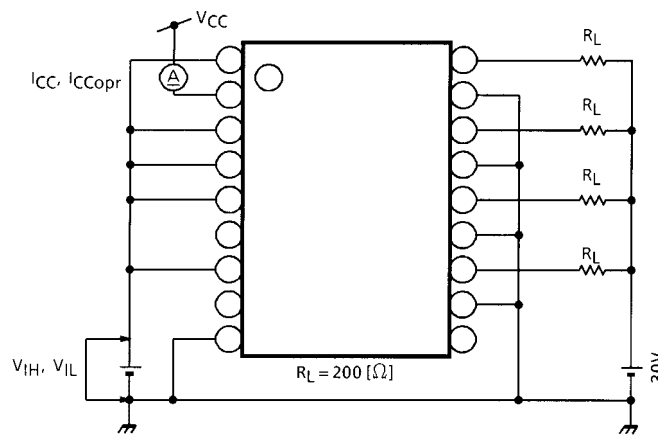

(5) V_{f1}

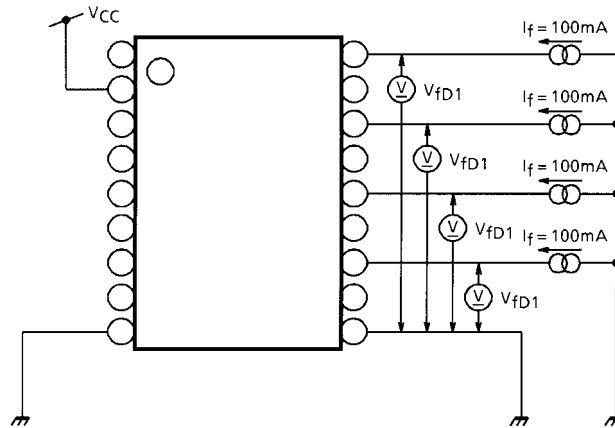

(6) t_{PDIO1} , t_{PDIO3} , t_{rOUT} , t_{fOUT}

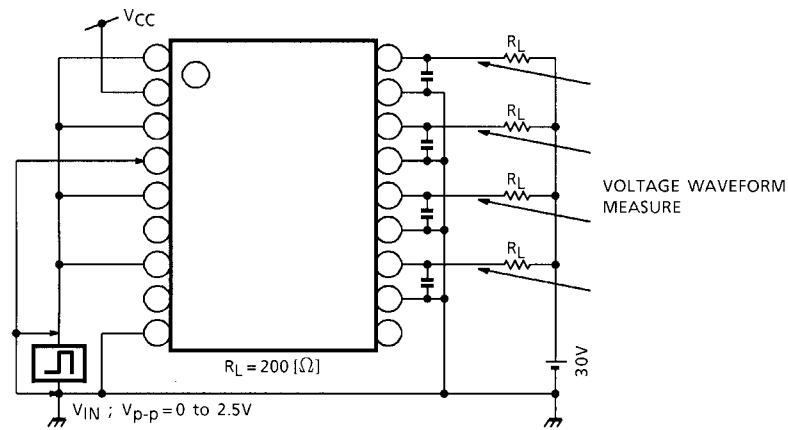

(7) t_{PDIO2} , t_{rERR} , t_{fERR} , $C(LP)$

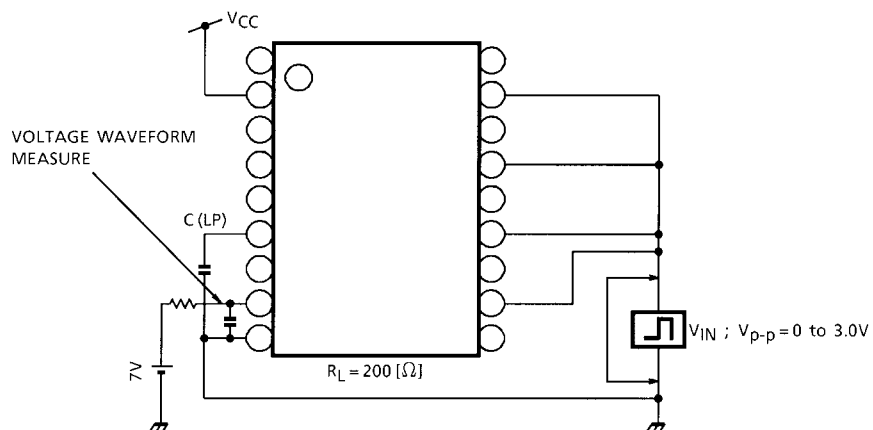

SWITCHING WAVEFORM

[$t_{PDIO1, 3}$, t_{rOUT} , t_{fOUT}]

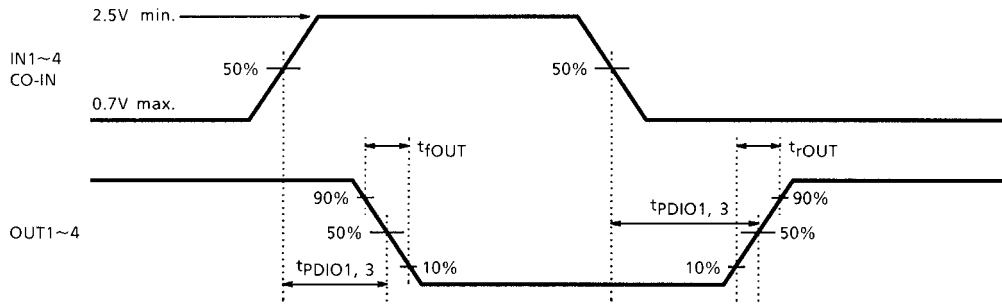

[t_{PDIO2} , t_{rERR} , t_{fERR}]

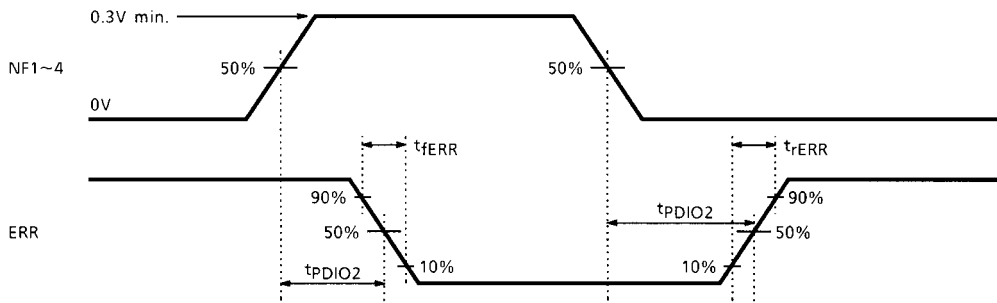

APPLICATION CIRCUIT

1. Using resistive load drive

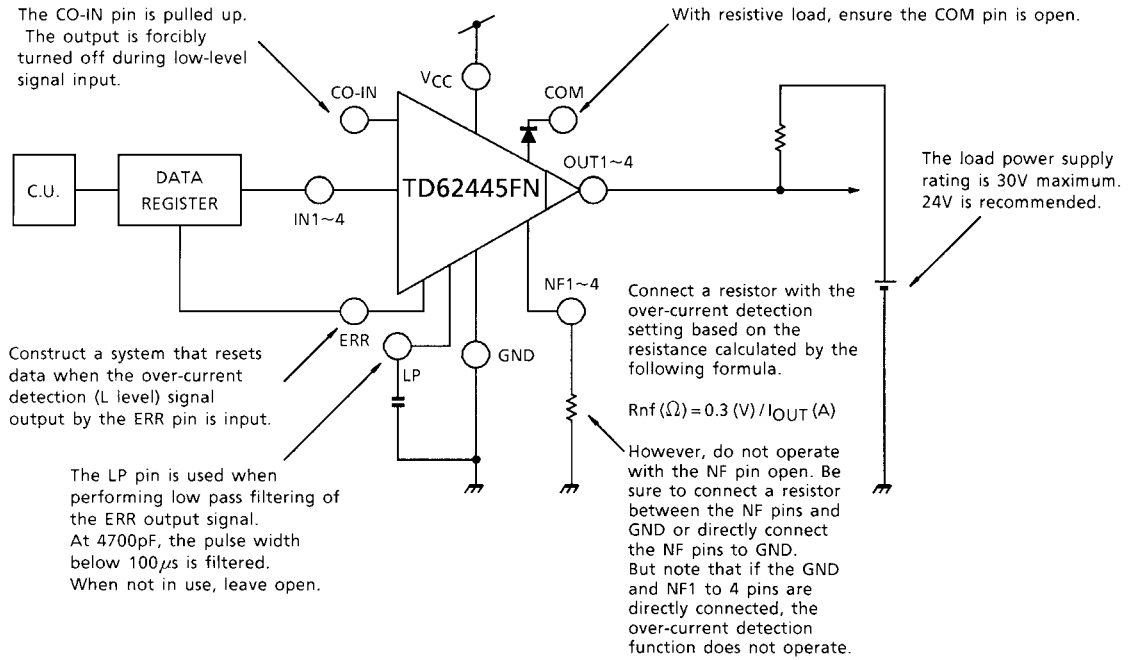

2. Using inductive load (eg, relay) drive

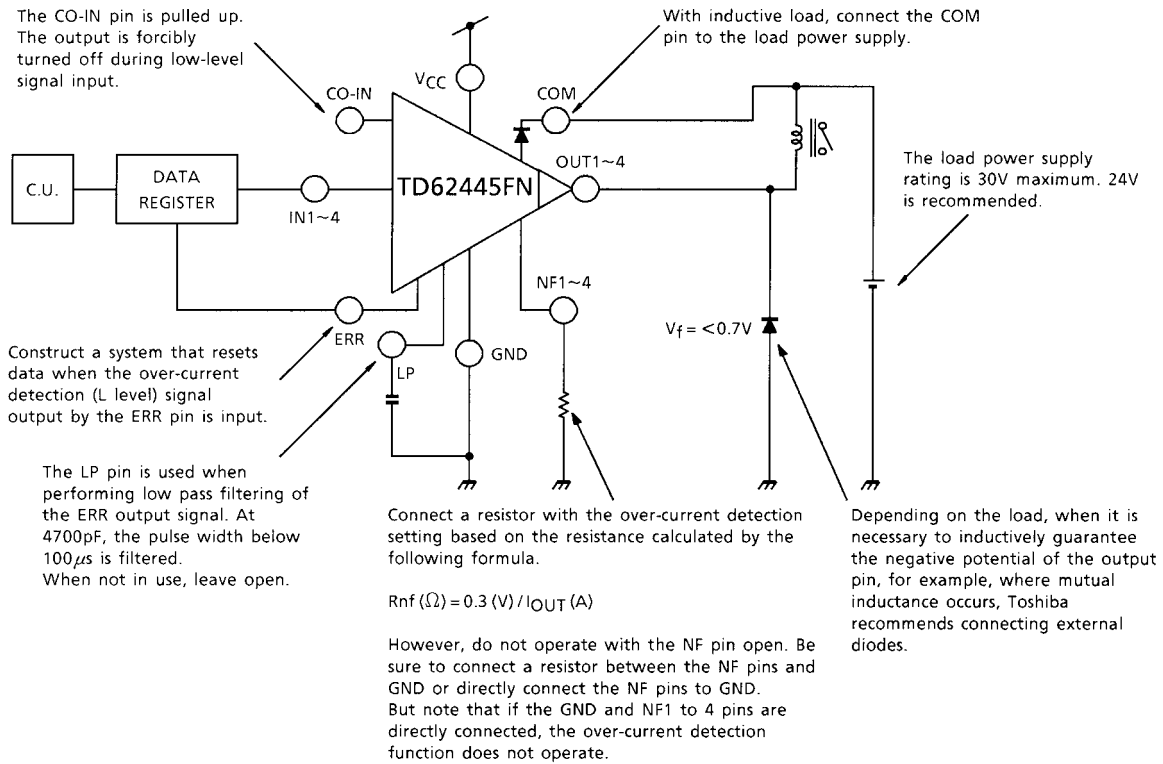

PRECAUTIONS for USING

This IC does not integrate protection circuits such as overcurrent and overvoltage protectors. Thus, if excess current or voltage is applied to the IC, the IC may be damaged. Please design the IC so that excess current or voltage will not be applied to the IC.

Utmost care is necessary in the design of the output line, VCC, COMMON and GND line since IC may be destroyed due to short-circuit between outputs, air contamination fault, or fault by improper grounding.

detectable pulse width
(At $T_a = 25^\circ\text{C}$, ERR pin outputs a low-level pulse width of $1\mu\text{s}$.)

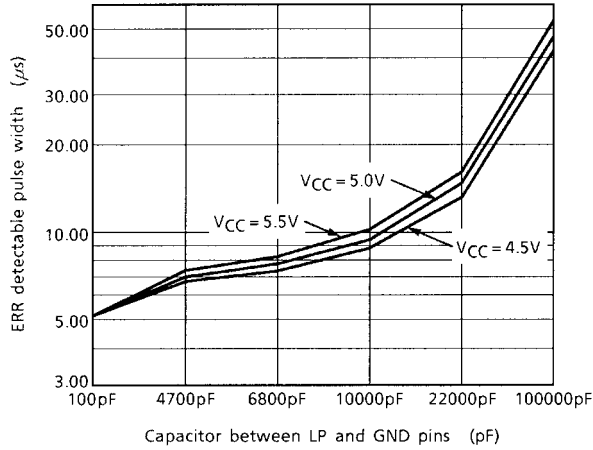

Output pin OUTn
Output saturation voltage vs Output pin current

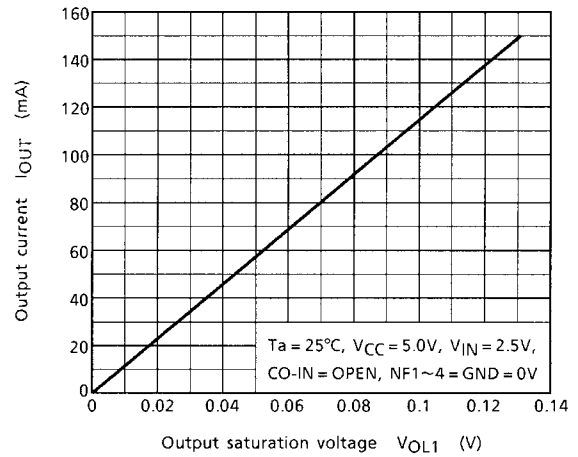

ERR pin
Output saturation voltage vs Output pin current

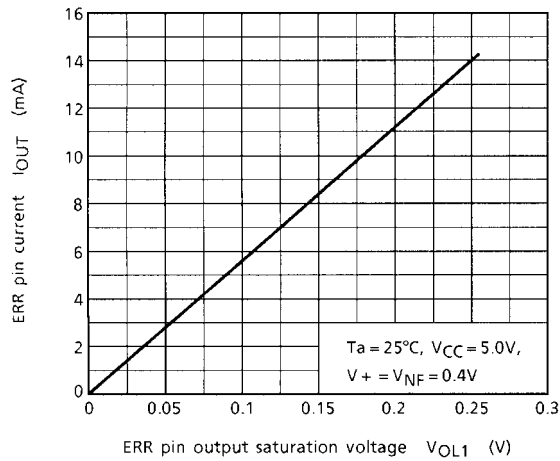

Input pin INn
Input pin voltage vs Input pin current

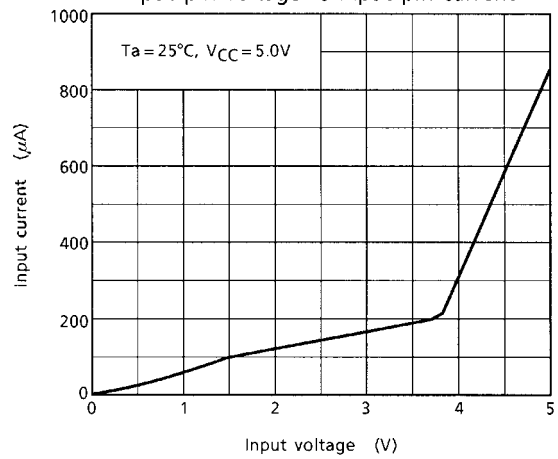

Clamp diode COM
Forward voltage V_f vs Forward current I_f
characteristics

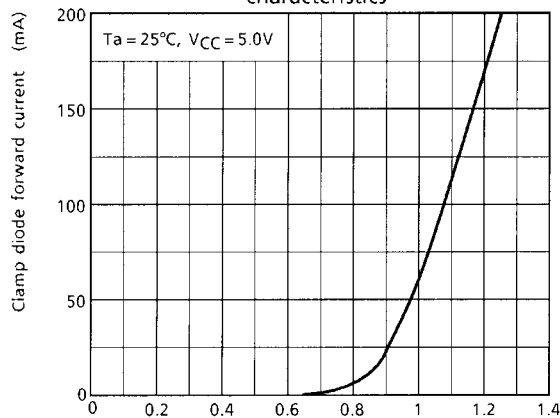

Power supply voltage V_{CC}
Applied power supply voltage V_{CC} vs Power
supply current during operation I_{CCopr}

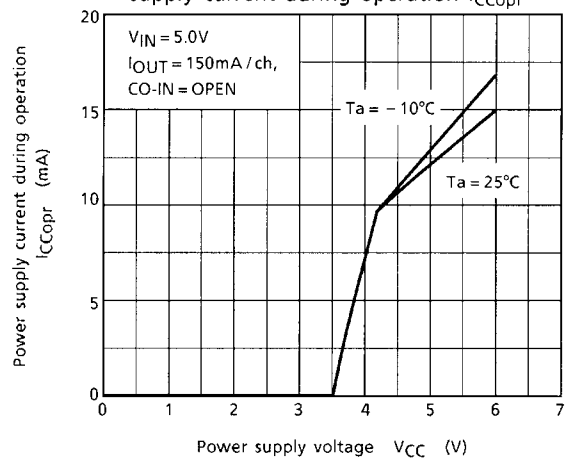

PACKAGE DIMENSIONS

SSOP18-P-225-0.65

Unit: mm

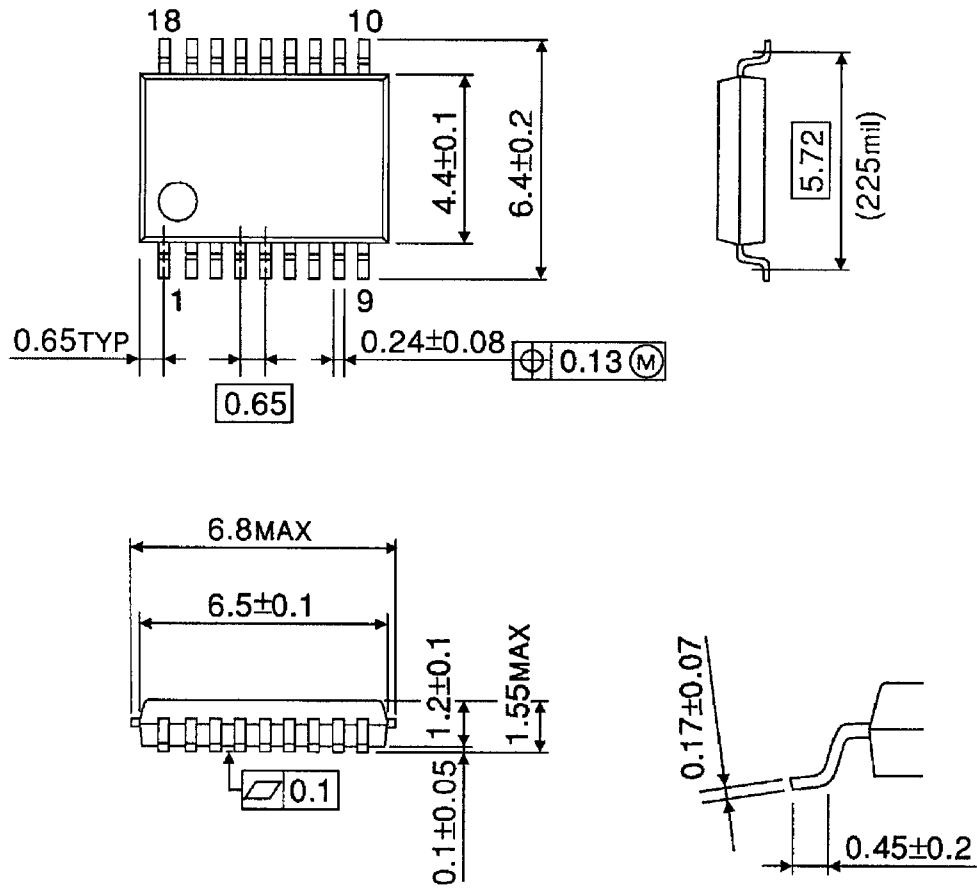

Weight: 0.08 g (Typ.)

RESTRICTIONS ON PRODUCT USE

000707EBA

- TOSHIBA is continually working to improve the quality and reliability of its products. Nevertheless, semiconductor devices in general can malfunction or fail due to their inherent electrical sensitivity and vulnerability to physical stress. It is the responsibility of the buyer, when utilizing TOSHIBA products, to comply with the standards of safety in making a safe design for the entire system, and to avoid situations in which a malfunction or failure of such TOSHIBA products could cause loss of human life, bodily injury or damage to property.
In developing your designs, please ensure that TOSHIBA products are used within specified operating ranges as set forth in the most recent TOSHIBA products specifications. Also, please keep in mind the precautions and conditions set forth in the "Handling Guide for Semiconductor Devices," or "TOSHIBA Semiconductor Reliability Handbook" etc..
- The TOSHIBA products listed in this document are intended for usage in general electronics applications (computer, personal equipment, office equipment, measuring equipment, industrial robotics, domestic appliances, etc.). These TOSHIBA products are neither intended nor warranted for usage in equipment that requires extraordinarily high quality and/or reliability or a malfunction or failure of which may cause loss of human life or bodily injury ("Unintended Usage"). Unintended Usage include atomic energy control instruments, airplane or spaceship instruments, transportation instruments, traffic signal instruments, combustion control instruments, medical instruments, all types of safety devices, etc.. Unintended Usage of TOSHIBA products listed in this document shall be made at the customer's own risk.
- The products described in this document are subject to the foreign exchange and foreign trade laws.
- The information contained herein is presented only as a guide for the applications of our products. No responsibility is assumed by TOSHIBA CORPORATION for any infringements of intellectual property or other rights of the third parties which may result from its use. No license is granted by implication or otherwise under any intellectual property or other rights of TOSHIBA CORPORATION or others.
- The information contained herein is subject to change without notice.