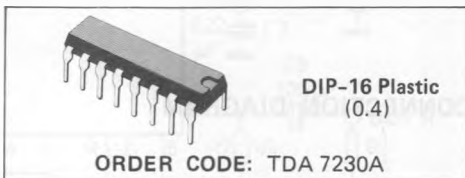
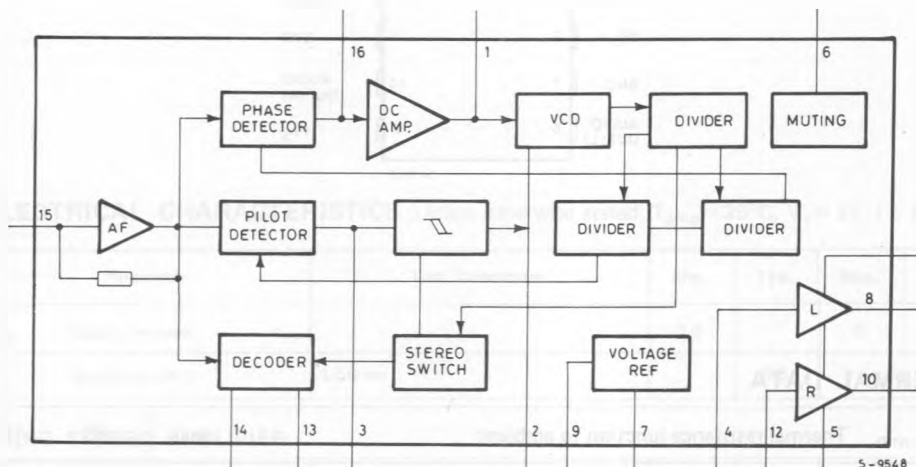

STEREO DECODER AND HEADPHONE AMPLIFIER

- OPERATING SUPPLY VOLTAGE RANGE: 1.8 to 6V
- LED DRIVING FOR STEREO INDICATION
- STEREO/MONO SWITCH
- ONLY OSCILLATOR FREQUENCY ADJUSTMENT NECESSARY
- LOW DISTORTION AND LOW NOISE
- VERY LOW POP ON/OFF NOISE
- FEW EXTERNAL COMPONENTS
- SOFT CLIPPING

The TDA7230A is a monolithic integrated circuit in 16 pin plastic package designed for stereo decoder and headphone amplifier applications in portable radio.

BLOCK DIAGRAM

ABSOLUTE MAXIMUM RATINGS

V_s	Supply voltage	9	V
I_L	LED current	8	mA
I_O	Peak output current	200	mA
P_{tot}	Total power dissipation at $T_{amb} = 70^\circ\text{C}$	1	W

CONNECTION DIAGRAM

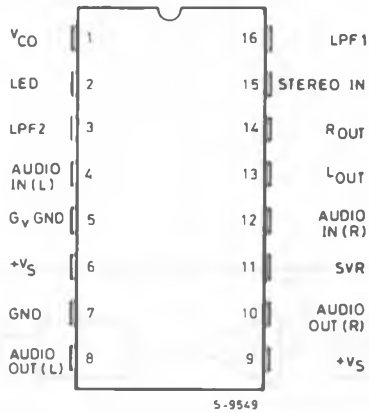

THERMAL DATA

$R_{th\ j-amb}$	Thermal resistance junction to ambient	max	80	$^\circ\text{C/W}$
-----------------	--	-----	----	--------------------

TEST CIRCUIT

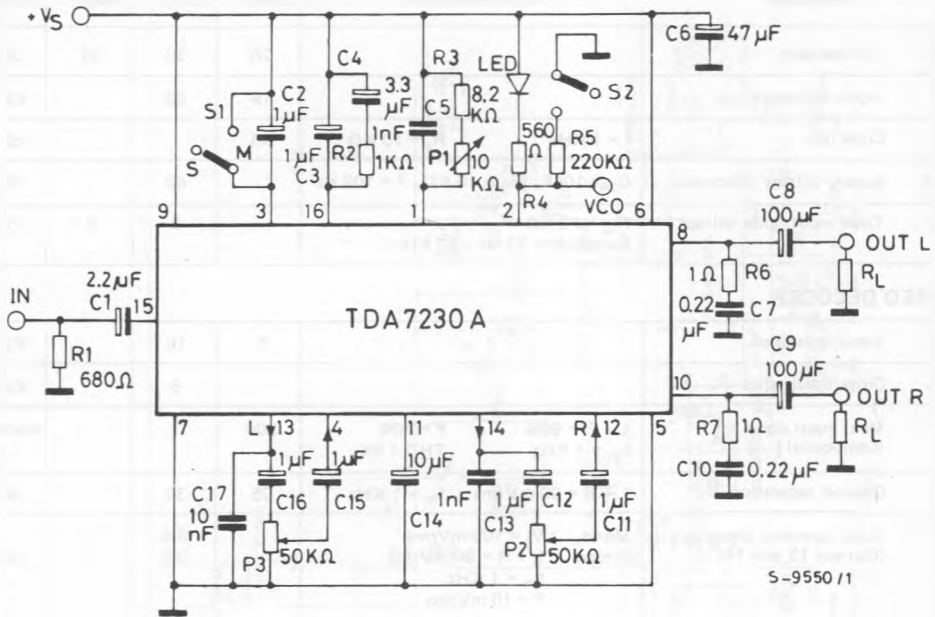
ELECTRICAL CHARACTERISTICS (Unless otherwise stated, $T_{amb} = 25^{\circ}\text{C}$, $V_s = 3\text{V}$, $f = 1\text{KHz}$)

Parameter	Test Conditions	Min.	Typ.	Max.	Unit
V_s Supply voltage		1.8		6	V
I_s Supply current	LED on		9.5		mA

AUDIO STEREO AMPLIFIER

P_o Output power	$V_s = 3\text{V}$, $R_L = 32\Omega$, $d = 10\%$	27	30		mW
	$V_s = 3\text{V}$, $R_L = 16\Omega$, $d = 10\%$	45	48		mW
	$V_s = 1.8\text{V}$, $R_L = 32\Omega$, $d = 10\%$	6	7		mW
d Distortion	$P_o = 10\text{mW}$, $f = 1\text{KHz}$, $R_L = 32\Omega$		0.2	1	%

ELECTRICAL CHARACTERISTICS (continued)

Parameter		Test Conditions	Min.	Typ.	Max.	Unit
G_v	Voltage gain		28	30	32	dB
R_i	Input resistance		15	20		$K\Omega$
	Cross talk	$f = 1 \text{ KHz}$ $R_s = 10 \text{ K}\Omega$	40			dB
SVR	Supply voltage rejection	$C_{14} = 10\mu\text{F}$, $R_g = 10 \text{ K}\Omega$, $f = 100 \text{ Hz}$		40		dB
e_N	Total input noise voltage	$R_G = 10 \text{ K}\Omega$ Bandwidth: 22 Hz - 22 KHz		2	5	μV

STEREO DECODER

R_i	Input resistance		6	10		$K\Omega$
R_o	Output resistance			5		$K\Omega$
V_i	Max. Input signal (composite)	$L + R = 90\%$ $P = 10\%$ $f_m = 1 \text{ KHz}$ THD = 5%	200			mVrms
S_c	Channel separation	$L + R = 90 \text{ mVrms}$ $f_m = 1 \text{ KHz}$	25	35		dB
d	Total harmonic distortion (Out pin 13, pin 14)	Mono $V_i = 100 \text{ mVrms}$ Stereo $L + R = 90 \text{ mVrms}$ $f_m = 1 \text{ KHz}$ $P = 10 \text{ mVrms}$		0.4 0.5	1 1	%
G_v	Voltage gain	$V_i = 100 \text{ mVrms}$	-3		+3	dB
	Channel balance	$V_i = 100 \text{ mVrms}$	-1	0	+1	dB
	LED on	Pilot input		8	11	mVrms
	LED off			6		mVrms
	LED Hysteresis	Turn OFF from Turn ON		3		mVrms
	Capture range	$P = 10 \text{ mVrms}$		± 3		%
S/N	Carrier leak 19 KHz 38 KHz	$P = 10 \text{ mVrms}$ $L + R = 90\text{mVrms}$	-25 -40	-32 -48		dB dB
S/N	Signal to noise	$V_i = 100 \text{ mVrms}$ $R_G = 600\Omega$		82		dB

TYPICAL APPLICATION

Fig. 1 - 3V stereo AM/FM mini-radio

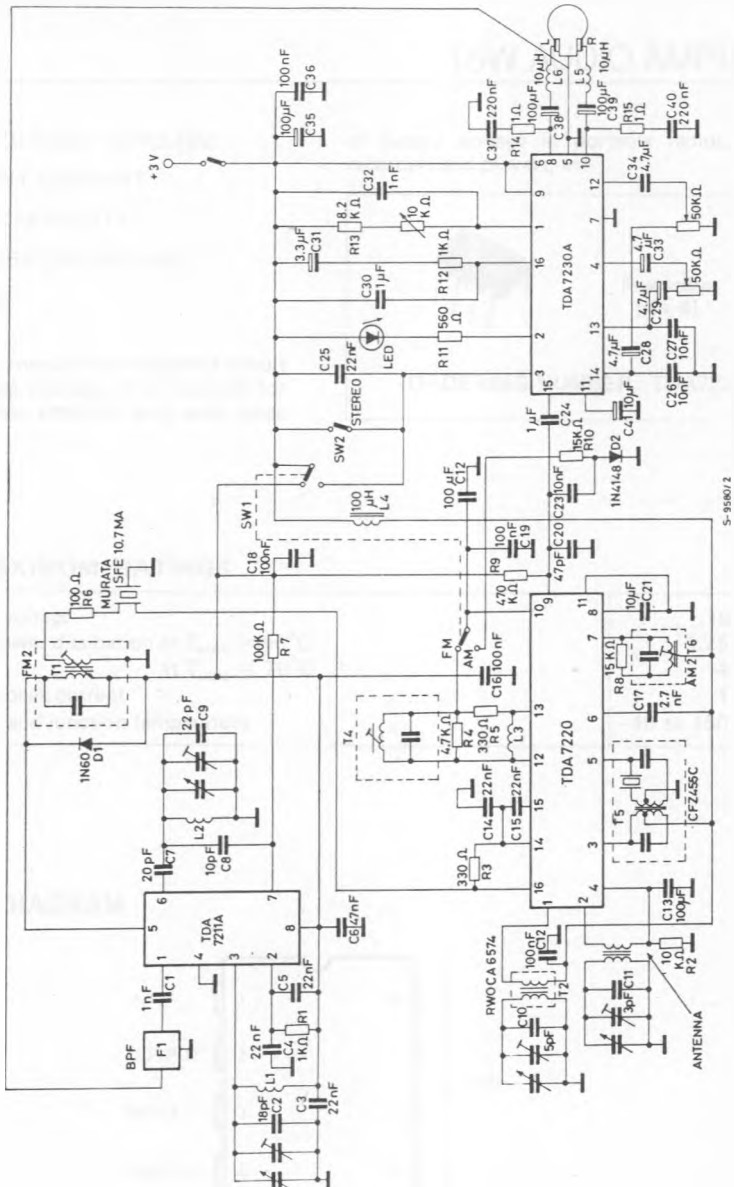

S-9580/2