

AM/FM CAR RADIO SYSTEM

ADVANCE DATA

The TDA7322 is high performance AM/FM radio IC designed for use in a wide range of car radio and home radio applications, operating with a supply voltage from 7 to 14V. The TDA7322 is supplied in a 20 pin plastic DIP package.

AM SECTION

- WB balanced RF amplifier
- Double balanced mixer
- Balanced detector
- Level controlled oscillator
- Oscillator booster for digital tuning
- Field strength meter

FM SECTION

- IF balanced amplifier and limiter
- Quadrature detector
- Field strength meter and AFC outputs
- Adjustable interstation noise mute
- Stop station function

FEATURES

- Soft AM/FM switching μ P compatible
- High recovered audio signal
- Very good AM signal handling
- Suitable for capacitance, varicap and inductive tuning (SW included)
- Low crossmodulation
- Very low tweet

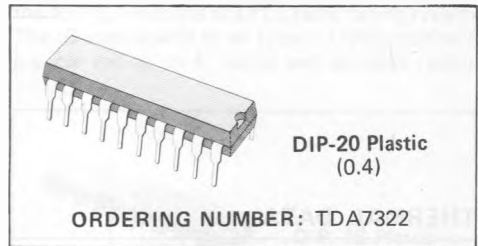

ABSOLUTE MAXIMUM RATINGS

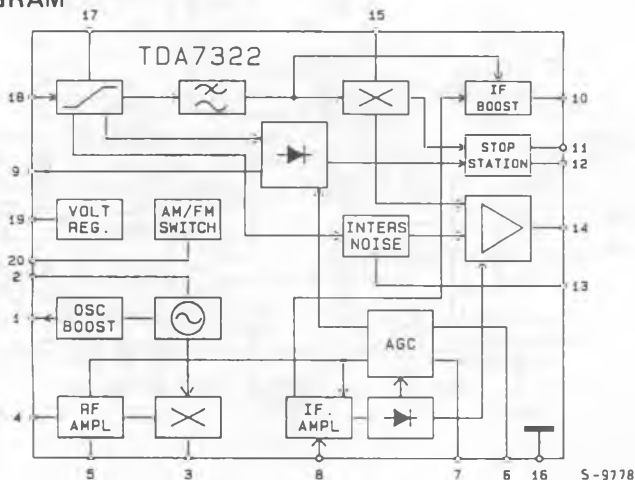
V_s	Supply voltage	14	V
P_{tot}	Total power dissipation at $T_{amb} < 85^\circ\text{C}$	0.8	W
T_{op}	Operating temperature	-30 to 85	$^\circ\text{C}$
T_{stg}, T_j	Storage and junction temperature	-56 to 150	$^\circ\text{C}$

BLOCK DIAGRAM

CONNECTION DIAGRAM

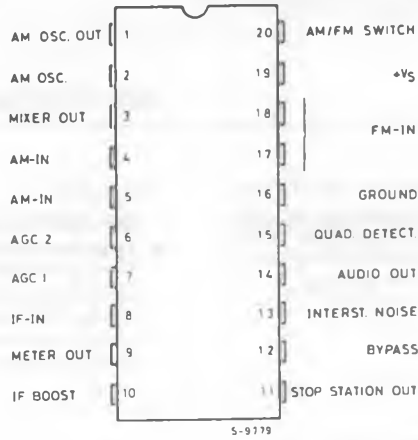
(Top view)



THERMAL DATA

$R_{thj-amb}$	Thermal resistance junction-ambient	max	80 °C/W
---------------	-------------------------------------	-----	---------

Fig. 1 - Test circuit

