

DATA SHEET

TDA8011T IF amplifier for satellite TV receivers

Product specification
File under Integrated Circuits, IC02

February 1995

Philips Semiconductors



PHILIPS

IF amplifier for satellite TV receivers

TDA8011T

FEATURES

- High voltage gain, up to 860 MHz
- Low noise
- Large dynamic gain control
- High impedance differential input stage
- Low output impedance.

APPLICATIONS

- Second IF amplifier for satellite TV receivers.

DESCRIPTION

The TDA8011T is a broadband low-noise AGC amplifier which is used for the second IF amplifier in satellite TV receivers. The amplifier is powered from a single 5 V supply. The amplifier gain can be easily controlled over a large dynamic range by using a single ground reference voltage. The two outputs are 180° out of phase and are separately buffered. The two outputs can therefore, be used in either the differential or asymmetrical mode.

QUICK REFERENCE DATA

SYMBOL	PARAMETER	CONDITIONS	MIN.	TYP.	MAX.	UNIT
V_{CC}	supply voltage		4.5	5.0	5.5	V
I_{CC}	supply current	$V_{CC} = 5\text{ V}; T_{amb} = 25\text{ °C}; I_{AGC} = 0\text{ mA}$	27	35	45	mA
V_i	input voltage level		–	–	96	dB μ V
V_o	output voltage level		–	–	85	dB μ V
$G_{V(max)}$	maximum voltage gain		25	–	–	dB
$G_{V(min)}$	minimum voltagegain		–	–	–21	dB

ORDERING INFORMATION

TYPE NUMBER	PACKAGE		
	NAME	DESCRIPTION	VERSION
TDA8011T	SO8	plastic small outline package; 8 leads; body width 3.9 mm	SOT96-1

IF amplifier for satellite TV receivers

TDA8011T

BLOCK DIAGRAM

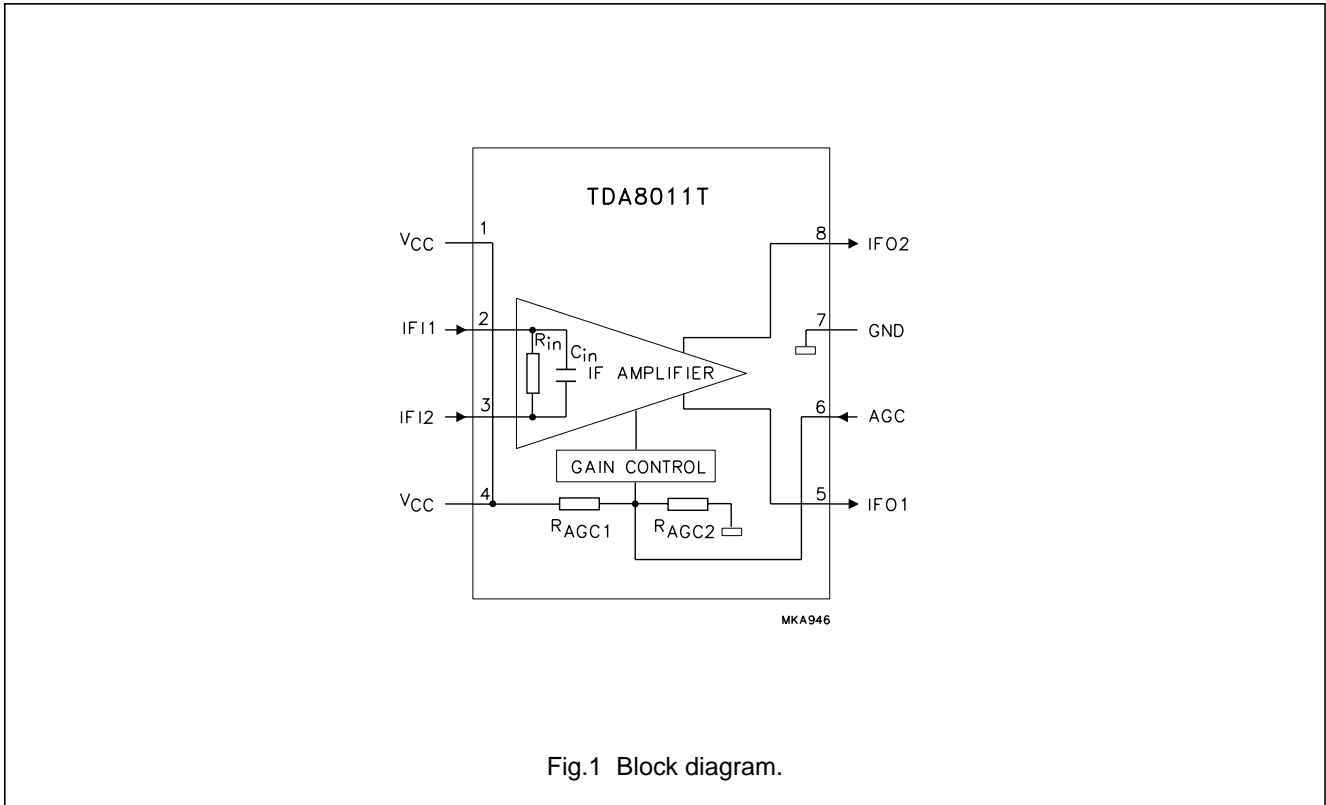

PINNING

SYMBOL	PIN	DESCRIPTION
V _{CC}	1	supply voltage
IFI1	2	IF input 1
IFI2	3	IF input 2
V _{CC}	4	supply voltage
IFO1	5	IF output 1
AGC	6	AGC input
GND	7	ground
IFO2	8	IF output 2

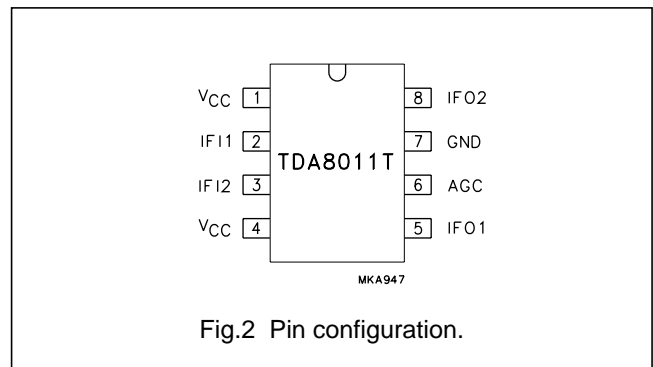

IF amplifier for satellite TV receivers

TDA8011T

LIMITING VALUES

In accordance with the Absolute Maximum Rating System (IEC 134).

SYMBOL	PARAMETER	MIN.	MAX.	UNIT
V_{CC}	supply voltage	-0.3	6.0	V
$V_{(max)}$	maximum voltage on all pins	-0.3	V_{CC}	V
$I_{source(max)}$	maximum output source current	-	10	mA
$t_{sc(max)}$	maximum short-circuit time on outputs	-	10	s
T_{stg}	storage temperature	-55	+150	°C
T_j	junction temperature	-	+150	°C
T_{amb}	operating ambient temperature	-10	+80	°C

THERMAL CHARACTERISTICS

SYMBOL	PARAMETER	VALUE	UNIT
$R_{th\ j-a}$	thermal resistance from junction to ambient in free air	160	K/W

HANDLING

Inputs and outputs are protected against electrostatic discharge in normal handling. However, to be totally safe it is desirable to take normal precautions appropriate to handling MOS devices.

CHARACTERISTICS

$V_{CC} = 5\text{ V}$; $f_i = 70, 480\text{ and }610\text{ MHz}$; $T_{amb} = 25\text{ °C}$; measured in application circuit of Fig.6; unless otherwise specified.

SYMBOL	PARAMETER	CONDITIONS	MIN.	TYP.	MAX.	UNIT
Supply						
I_{CC}	supply current		27	35	45	mA
IF amplifier						
$G_{V(max)}$	maximum voltage gain	$V_{AGC} = 0.9V_{CC}$; note 1	25	-	-	dB
$G_{V(min)}$	minimum voltage gain	$V_{AGC} = 0.1V_{CC}$; note 1	-	-	-21	dB
ΔG	tilt	$\Delta f_i = 20\text{ MHz}$; note 2	-	0.4	-	dB
V_i	input voltage level		-	-	96	dB μ V
$V_{I(DC)}$	DC input voltage level		-	2.5	-	V
V_o	output voltage level		-	-	85	dB μ V
$V_{O(DC)}$	DC output voltage level		-	2.2	-	V
F	noise figure	unmatched configuration; note 3	-	-	15	dB
$F_{(min)}$	minimum noise figure	note 4	-	-	11	dB
IM3	third-order intermodulation distance	note 5	-	40	-	dB
$R_{i(diff)}$	differential input resistance	note 6	-	4	-	k Ω
$C_{i(diff)}$	differential input capacitance	note 6	-	0.75	-	pF
$R_{o(SE)}$	single-ended output resistance		-	50	-	Ω

IF amplifier for satellite TV receivers

TDA8011T

SYMBOL	PARAMETER	CONDITIONS	MIN.	TYP.	MAX.	UNIT
Gain control						
V _{AGC}	AGC input voltage	G ≤ G _{v(min)}	0.1V _{CC}	–	–	V
		G ≥ G _{v(max)}	–	–	0.9V _{CC}	V
R _{AGC1}	AGC resistor 1		–	4.3	–	kΩ
R _{AGC2}	AGC resistor 2		–	110	–	kΩ

Notes

- The voltage gain G_v is defined as the ratio between the single-ended output voltage and the differential input voltage with a 150 Ω output load: $G = 20 \times \log \left(\frac{V_{IF0}}{V_i} \right)$
- The tilt is defined as the maximum absolute difference between the gain at the frequency f_o = 480 MHz and the gain at the frequency f_o = 480 MHz ±20 MHz. Where $\Delta G_v = \max |G(f_o \pm \Delta f) - G(f_o)|$
- The unmatched noise figure (F) is measured at f_i = 480 MHz in the application circuit (see Fig.6). With the hybrid coupler used, the equivalent source impedance is equal to 100 Ω.
- The minimum noise figure [F_(min)] is measured at f_i = 480 MHz with the input matching circuit shown in Fig.3; (L1: 4.5 turns on, Φ_{int} = 3 mm, wire = 0.4 mm; L2: 11 turns on, Φ_{int} = 3 mm, wire = 0.4 mm).
- The third-order intermodulation distance (IM3) is measured with an AGC voltage set to obtain a gain of –17 dB. The input signal applied to the amplifier consists of two sine wave signals at f_i = 479.5 MHz and f_i = 480.5 MHz with an amplitude equal to 90 dBμV for each tone.
- The differential input impedance is represented by an equivalent parallel resistance and capacitance as shown in Fig.1. The specified values are measured at f_i = 480 MHz.

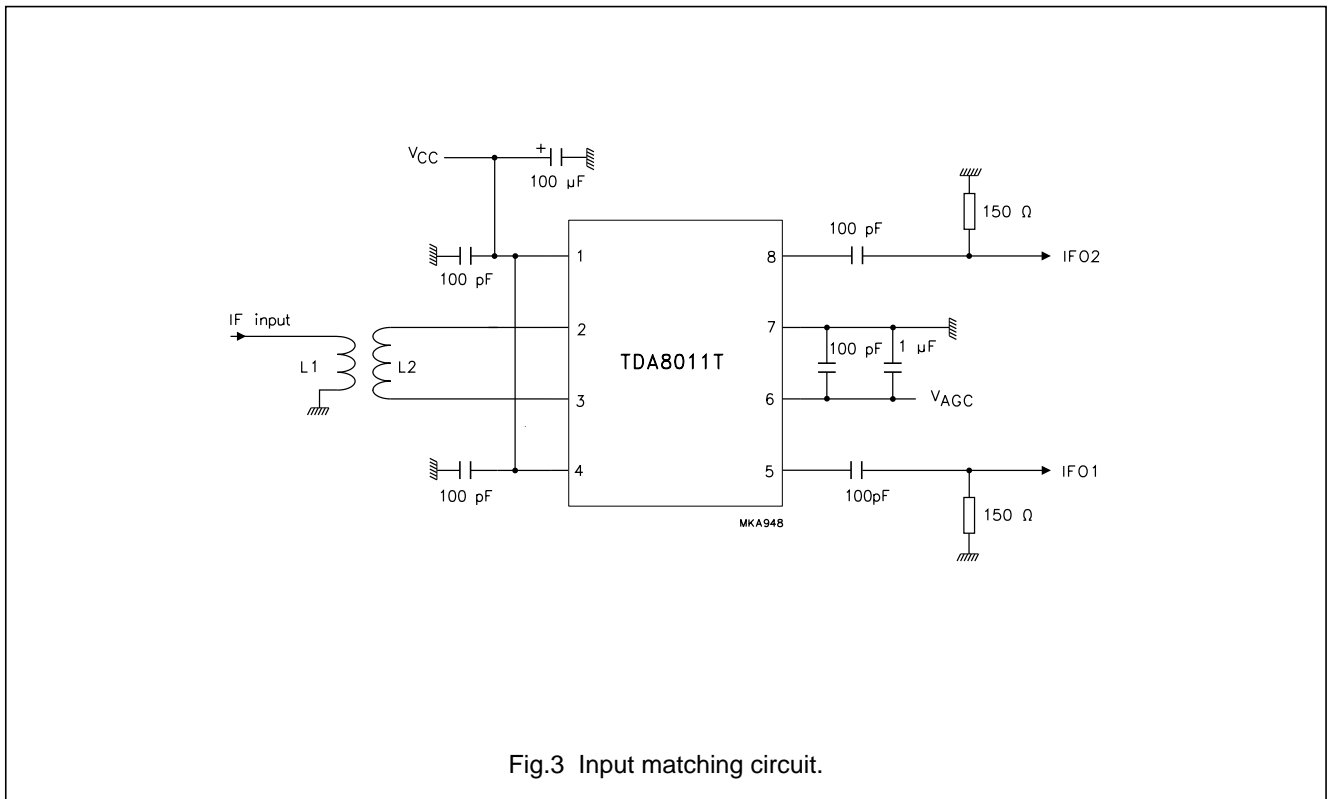

Fig.3 Input matching circuit.

IF amplifier for satellite TV receivers

TDA8011T

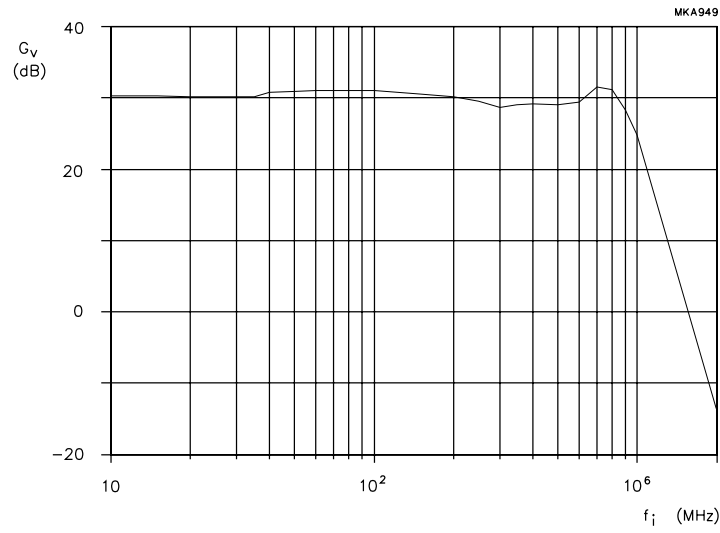

Fig.4 Typical frequency response curve.

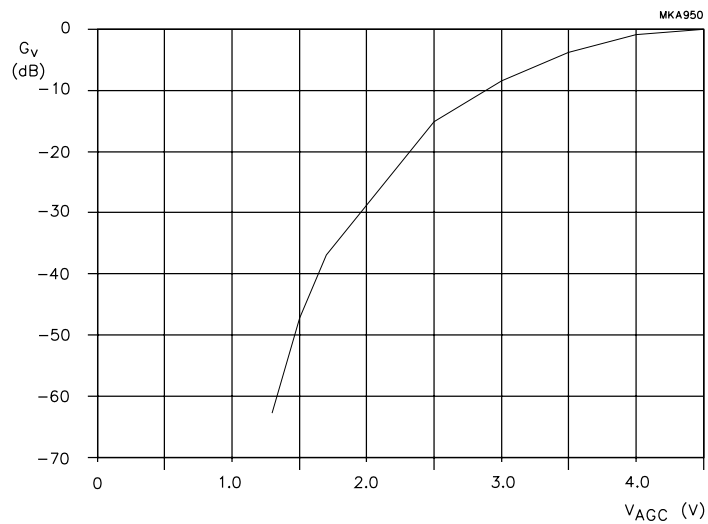

Fig.5 Typical gain control response curve.

IF amplifier for satellite TV receivers

TDA8011T

APPLICATION INFORMATION

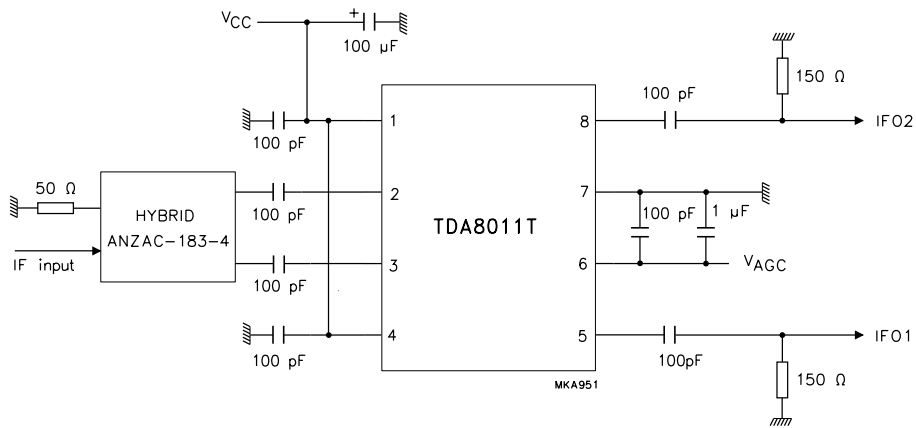

Fig.6 Application circuit.

IF amplifier for satellite TV receivers

TDA8011T

PACKAGE OUTLINE

S08: plastic small outline package; 8 leads; body width 3.9 mm

SOT96-1

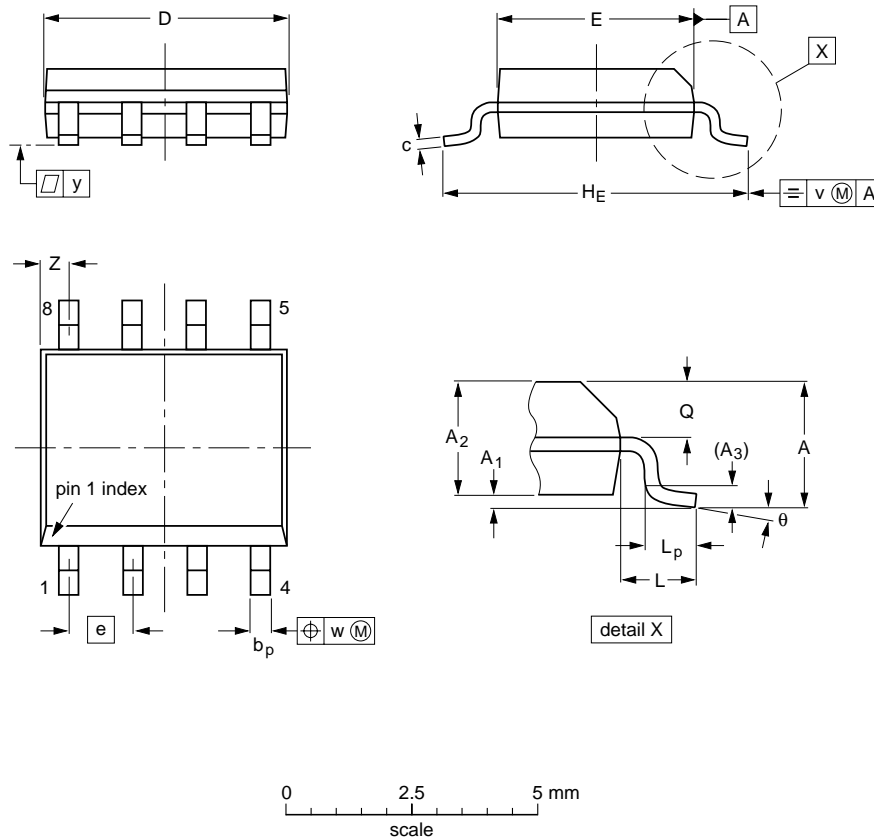

DIMENSIONS (inch dimensions are derived from the original mm dimensions)

UNIT	A max.	A ₁	A ₂	A ₃	b _p	c	D ⁽¹⁾	E ⁽²⁾	e	H _E	L	L _p	Q	v	w	y	z ⁽¹⁾	θ
mm	1.75	0.25 0.10	1.45 1.25	0.25	0.49 0.36	0.25 0.19	5.0 4.8	4.0 3.8	1.27	6.2 5.8	1.05	1.0 0.4	0.7 0.6	0.25	0.25	0.1	0.7 0.3	8° 0°
inches	0.069	0.010 0.004	0.057 0.049	0.01	0.019 0.014	0.0100 0.0075	0.20 0.19	0.16 0.15	0.050	0.244 0.228	0.041	0.039 0.016	0.028 0.024	0.01	0.01	0.004	0.028 0.012	

Notes

1. Plastic or metal protrusions of 0.15 mm maximum per side are not included.
2. Plastic or metal protrusions of 0.25 mm maximum per side are not included.

OUTLINE VERSION	REFERENCES				EUROPEAN PROJECTION	ISSUE DATE
	IEC	JEDEC	EIAJ			
SOT96-1	076E03S	MS-012AA				95-02-04 97-05-22

IF amplifier for satellite TV receivers

TDA8011T

SOLDERING

Plastic small-outline packages

BY WAVE

During placement and before soldering, the component must be fixed with a droplet of adhesive. After curing the adhesive, the component can be soldered. The adhesive can be applied by screen printing, pin transfer or syringe dispensing.

Maximum permissible solder temperature is 260 °C, and maximum duration of package immersion in solder bath is 10 s, if allowed to cool to less than 150 °C within 6 s. Typical dwell time is 4 s at 250 °C.

A modified wave soldering technique is recommended using two solder waves (dual-wave), in which a turbulent wave with high upward pressure is followed by a smooth laminar wave. Using a mildly-activated flux eliminates the need for removal of corrosive residues in most applications.

BY SOLDER PASTE REFLOW

Reflow soldering requires the solder paste (a suspension of fine solder particles, flux and binding agent) to be

applied to the substrate by screen printing, stencilling or pressure-syringe dispensing before device placement.

Several techniques exist for reflowing; for example, thermal conduction by heated belt, infrared, and vapour-phase reflow. Dwell times vary between 50 and 300 s according to method. Typical reflow temperatures range from 215 to 250 °C.

Preheating is necessary to dry the paste and evaporate the binding agent. Preheating duration: 45 min at 45 °C.

REPAIRING SOLDERED JOINTS (BY HAND-HELD SOLDERING IRON OR PULSE-HEATED SOLDER TOOL)

Fix the component by first soldering two, diagonally opposite, end pins. Apply the heating tool to the flat part of the pin only. Contact time must be limited to 10 s at up to 300 °C. When using proper tools, all other pins can be soldered in one operation within 2 to 5 s at between 270 and 320 °C. (Pulse-heated soldering is not recommended for SO packages.)

For pulse-heated solder tool (resistance) soldering of VSO packages, solder is applied to the substrate by dipping or by an extra thick tin/lead plating before package placement.

DEFINITIONS

Data sheet status	
Objective specification	This data sheet contains target or goal specifications for product development.
Preliminary specification	This data sheet contains preliminary data; supplementary data may be published later.
Product specification	This data sheet contains final product specifications.
Limiting values	
Limiting values given are in accordance with the Absolute Maximum Rating System (IEC 134). Stress above one or more of the limiting values may cause permanent damage to the device. These are stress ratings only and operation of the device at these or at any other conditions above those given in the Characteristics sections of the specification is not implied. Exposure to limiting values for extended periods may affect device reliability.	
Application information	
Where application information is given, it is advisory and does not form part of the specification.	

LIFE SUPPORT APPLICATIONS

These products are not designed for use in life support appliances, devices, or systems where malfunction of these products can reasonably be expected to result in personal injury. Philips customers using or selling these products for use in such applications do so at their own risk and agree to fully indemnify Philips for any damages resulting from such improper use or sale.

IF amplifier for satellite TV receivers

TDA8011T

NOTES

IF amplifier for satellite TV receivers

TDA8011T

NOTES

Philips Semiconductors – a worldwide company

Argentina: IEROD, Av. Juramento 1992 - 14.b, (1428)
BUENOS AIRES, Tel. (541)786 7633, Fax. (541)786 9367

Australia: 34 Waterloo Road, NORTH RYDE, NSW 2113,
Tel. (02)805 4455, Fax. (02)805 4466

Austria: Triester Str. 64, A-1101 WIEN, P.O. Box 213,
Tel. (01)60 101-1236, Fax. (01)60 101-1211

Belgium: Postbus 90050, 5600 PB EINDHOVEN, The Netherlands,
Tel. (31)40 783 749, Fax. (31)40 788 399

Brazil: Rua do Rocio 220 - 5th floor, Suite 51,
CEP: 04552-903-SÃO PAULO-SP, Brazil.
P.O. Box 7383 (01064-970).

Tel. (011)821-2333, Fax. (011)829-1849

Canada: PHILIPS SEMICONDUCTORS/COMPONENTS:
Tel. (800) 234-7381, Fax. (708) 296-8556

Chile: Av. Santa Maria 0760, SANTIAGO,
Tel. (02)773 816, Fax. (02)777 6730

Colombia: IPRELENZO LTDA, Carrera 21 No. 56-17,
77621 BOGOTA, Tel. (571)249 7624/(571)217 4609,
Fax. (571)217 4549

Denmark: Prags Boulevard 80, PB 1919, DK-2300 COPENHAGEN S,
Tel. (032)88 2636, Fax. (031)57 1949

Finland: Sinikalliontie 3, FIN-02630 ESPOO,
Tel. (9)0-50261, Fax. (9)0-520971

France: 4 Rue du Port-aux-Vins, BP317,
92156 SURESNES Cedex,
Tel. (01)4099 6161, Fax. (01)4099 6427

Germany: P.O. Box 10 63 23, 20043 HAMBURG,
Tel. (040)3296-0, Fax. (040)3296 213.

Greece: No. 15, 25th March Street, GR 17778 TAVROS,
Tel. (01)4894 339/4894 911, Fax. (01)4814 240

Hong Kong: PHILIPS HONG KONG Ltd., 6/F Philips Ind. Bldg.,
24-28 Kung Yip St., KWAI CHUNG, N.T.,
Tel. (852)424 5121, Fax. (852)428 6729

India: Philips INDIA Ltd, Shivsagar Estate, A Block,
Dr. Annie Besant Rd. Worli, Bombay 400 018
Tel. (022)4938 541, Fax. (022)4938 722

Indonesia: Philips House, Jalan H.R. Rasuna Said Kav. 3-4,
P.O. Box 4252, JAKARTA 12950,
Tel. (021)5201 122, Fax. (021)5205 189

Ireland: Newstead, Clonskeagh, DUBLIN 14,
Tel. (01)640 000, Fax. (01)640 200

Italy: PHILIPS SEMICONDUCTORS S.r.l.,
Piazza IV Novembre 3, 20124 MILANO,
Tel. (0039)2 6752 2531, Fax. (0039)2 6752 2557

Japan: Philips Bldg 13-37, Kohnan2-chome, Minato-ku, TOKYO 108,
Tel. (03)3740 5028, Fax. (03)3740 0580

Korea: (Republic of) Philips House, 260-199 Itaewon-dong,
Yongsan-ku, SEOUL, Tel. (02)794-5011, Fax. (02)798-8022

Malaysia: No. 76 Jalan Universiti, 46200 PETALING JAYA,
SELANGOR, Tel. (03)750 5214, Fax. (03)757 4880

Mexico: 5900 Gateway East, Suite 200, EL PASO, TX 79905,
Tel. 9-5(800)234-7381, Fax. (708)296-8556

Netherlands: Postbus 90050, 5600 PB EINDHOVEN, Bldg. VB
Tel. (040)783749, Fax. (040)788399

New Zealand: 2 Wagener Place, C.P.O. Box 1041, AUCKLAND,
Tel. (09)849-4160, Fax. (09)849-7811

Norway: Box 1, Manglerud 0612, OSLO,
Tel. (022)74 8000, Fax. (022)74 8341

Pakistan: Philips Electrical Industries of Pakistan Ltd.,
Exchange Bldg. ST-2/A, Block 9, KDA Scheme 5, Clifton,
KARACHI 75600, Tel. (021)587 4641-49,
Fax. (021)577035/5874546.

Philippines: PHILIPS SEMICONDUCTORS PHILIPPINES Inc,
106 Valero St. Salcedo Village, P.O. Box 2108 MCC, MAKATI,
Metro MANILA, Tel. (02)810 0161, Fax. (02)817 3474

Portugal: PHILIPS PORTUGUESA, S.A.,
Rua dr. António Loureiro Borges 5, Arquiparque - Miraflores,
Apartado 300, 2795 LINDA-A-VELHA,
Tel. (01)4163160/4163333, Fax. (01)4163174/4163366.

Singapore: Lorong 1, Toa Payoh, SINGAPORE 1231,
Tel. (65)350 2000, Fax. (65)251 6500

South Africa: S.A. PHILIPS Pty Ltd.,
195-215 Main Road Martindale, 2092 JOHANNESBURG,
P.O. Box 7430 Johannesburg 2000,
Tel. (011)470-5911, Fax. (011)470-5494.

Spain: Balmes 22, 08007 BARCELONA,
Tel. (03)301 6312, Fax. (03)301 42 43

Sweden: Kottbygatan 7, Akalla. S-164 85 STOCKHOLM,
Tel. (0)8-632 2000, Fax. (0)8-632 2745

Switzerland: Allmendstrasse 140, CH-8027 ZÜRICH,
Tel. (01)488 2211, Fax. (01)481 77 30

Taiwan: PHILIPS TAIWAN Ltd., 23-30F, 66, Chung Hsiao West
Road, Sec. 1, Taipei, Taiwan ROC, P.O. Box 22978,
TAIPEI 100, Tel. (02)388 7666, Fax. (02)382 4382.

Thailand: PHILIPS ELECTRONICS (THAILAND) Ltd.,
209/2 Sanpavuth-Bangna Road Prakanong,
Bangkok 10260, THAILAND,
Tel. (662)398-0141, Fax. (662)398-3319.

Turkey: Talatpasa Cad. No. 5, 80640 GÜLTEPE/ISTANBUL,
Tel. (0212)279 2770, Fax. (0212)269 3094

United Kingdom: Philips Semiconductors LTD.,
276 Bath Road, Hayes, MIDDLESEX UB3 5BX,
Tel. (081)730-5000, Fax. (081)754-8421

United States: 811 East Arques Avenue, SUNNYVALE,
CA 94088-3409, Tel. (800)234-7381, Fax. (708)296-8556

Uruguay: Coronel Mora 433, MONTEVIDEO,
Tel. (02)70-4044, Fax. (02)92 0601

For all other countries apply to: Philips Semiconductors,
International Marketing and Sales, Building BE-p,
P.O. Box 218, 5600 MD, EINDHOVEN, The Netherlands,
Telex 35000 phtcnl, Fax. +31-40-724825

SCD36 © Philips Electronics N.V. 1994

All rights are reserved. Reproduction in whole or in part is prohibited without the prior written consent of the copyright owner.

The information presented in this document does not form part of any quotation or contract, is believed to be accurate and reliable and may be changed without notice. No liability will be accepted by the publisher for any consequence of its use. Publication thereof does not convey nor imply any license under patent- or other industrial or intellectual property rights.

Printed in The Netherlands

533061/1500/01/pp12
Document order number:

Date of release: February 1995
9397 746 70011

Philips Semiconductors



PHILIPS