

DATA SHEET

TDA8771A

Triple 8-bit video Digital-to-Analog
Converter (DAC)

Product specification
File under Integrated Circuits, IC02

1996 Jan 25

Triple 8-bit video Digital-to-Analog Converter (DAC)

TDA8771A

FEATURES

- 8-bit resolution
- Sampling rate up to 35 MHz
- Internal reference voltage regulator
- No deglitching circuit required
- Large output voltage range
- 1 k Ω output load
- Power dissipation only 200 mW
- Single 5 V power supply
- 44-pin QFP package.

GENERAL DESCRIPTION

The TDA8771A is a triple 8-bit video Digital-to-Analog Converter (DAC). It converts the digital input signals into analog voltage outputs at a maximum conversion rate of 35 MHz.

The DACs are based on resistor-string architecture with integrated output buffers. The output voltage range is determined by a built-in reference source.

The device is fabricated in a 5 V, CMOS process that ensures high functionality with low power dissipation.

APPLICATIONS

- General purpose high-speed digital-to-analog conversion
- Digital TV
- Graphic display
- Desktop video processing.

QUICK REFERENCE DATA

SYMBOL	PARAMETER	CONDITIONS	MIN.	TYP.	MAX.	UNIT
V _{DDA}	analog supply voltage		4.5	5.0	5.5	V
V _{DDD}	digital supply voltage		4.5	5.0	5.5	V
I _{DDA}	analog supply current	R _L = 1 k Ω ; note 1	10	33	45	mA
I _{DDD}	digital supply current	f _{clk} = 35 MHz	–	7	20	mA
INL	integral non-linearity	f _{clk} = 35 MHz; ramp input	–	±0.5	±1	LSB
DNL	differential non-linearity	f _{clk} = 35 MHz; ramp input	–	±0.25	±0.5	LSB
f _{clk(max)}	maximum clock frequency		35	–	–	MHz
P _{tot}	total power dissipation	R _L = 1 k Ω ; f _{clk} = 35 MHz; note 1	45	200	360	mW

Note

1. Minimum and maximum data of current and power consumption are measured in worse case conditions: for minimum data, all digital inputs are at logic level 0 while for maximum data, all digital inputs are at logic level 1.

ORDERING INFORMATION

TYPE NUMBER	PACKAGE		
	NAME	DESCRIPTION	VERSION
TDA8771AH	QFP44	plastic quad flat package; 44 leads (lead length 1.3 mm); body 10 × 10 × 1.75 mm	SOT307-2

Triple 8-bit video Digital-to-Analog Converter (DAC)

TDA8771A

BLOCK DIAGRAM

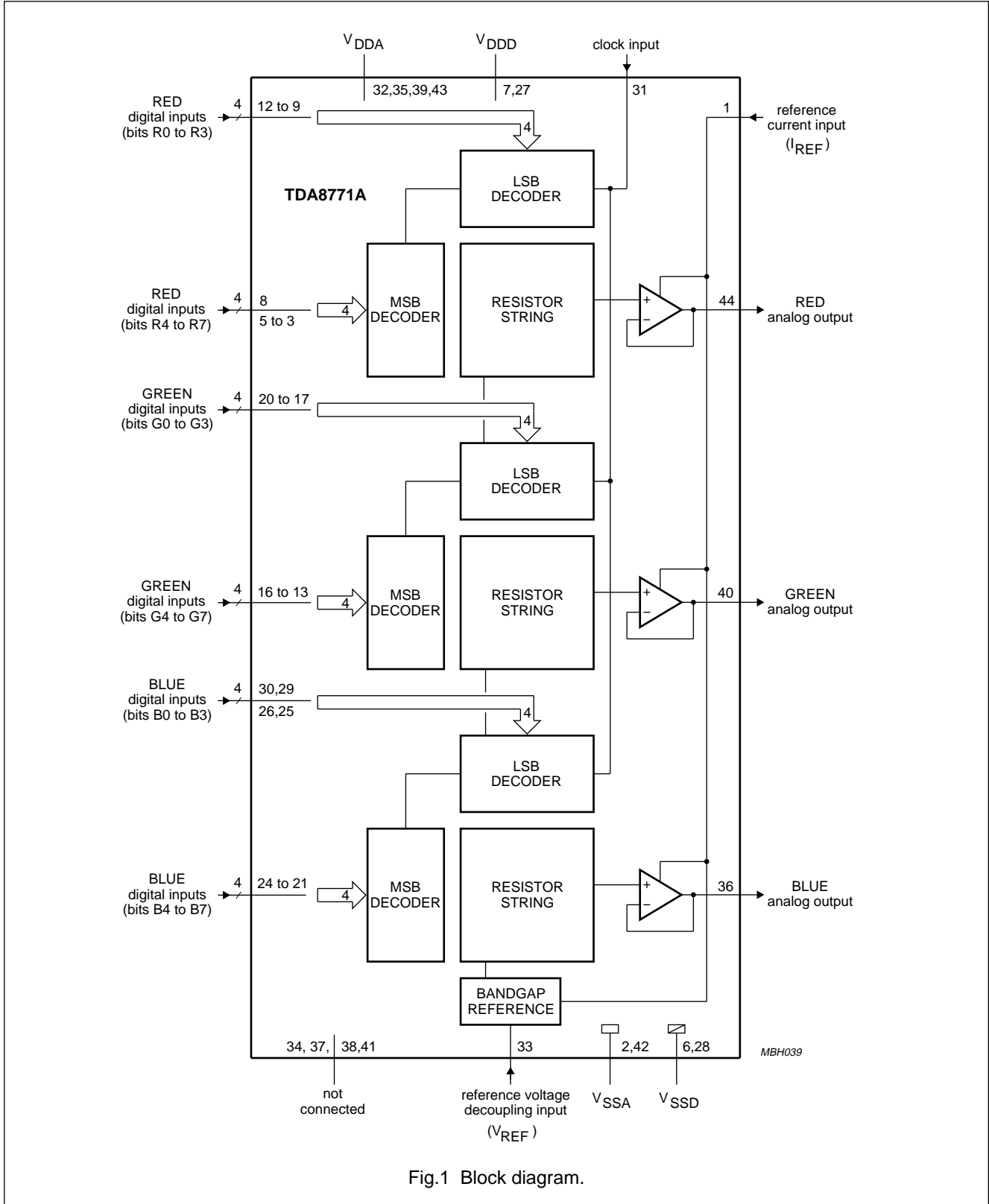

Fig.1 Block diagram.

Triple 8-bit video Digital-to-Analog Converter (DAC)

TDA8771A

PINNING

SYMBOL	PIN	DESCRIPTION
I _{REF}	1	reference current input for output buffers
V _{SSA1}	2	analog supply ground 1
R7	3	RED digital input data; bit 7 (MSB)
R6	4	RED digital input data; bit 6
R5	5	RED digital input data; bit 5
V _{SSD1}	6	digital supply ground 1
V _{DDD1}	7	digital supply voltage 1
R4	8	RED digital input data; bit 4
R3	9	RED digital input data; bit 3
R2	10	RED digital input data; bit 2
R1	11	RED digital input data; bit 1
R0	12	RED digital input data; bit 0 (LSB)
G7	13	GREEN digital input data; bit 7 (MSB)
G6	14	GREEN digital input data; bit 6
G5	15	GREEN digital input data; bit 5
G4	16	GREEN digital input data; bit 4
G3	17	GREEN digital input data; bit 3
G2	18	GREEN digital input data; bit 2
G1	19	GREEN digital input data; bit 1
G0	20	GREEN digital input data; bit 0 (LSB)
B7	21	BLUE digital input data; bit 7 (MSB)
B6	22	BLUE digital input data; bit 6
B5	23	BLUE digital input data; bit 5
B4	24	BLUE digital input data; bit 4
B3	25	BLUE digital input data; bit 3
B2	26	BLUE digital input data; bit 2
V _{DDD2}	27	digital supply voltage 2
V _{SSD2}	28	digital supply ground 2
B1	29	BLUE digital input data; bit 1
B0	30	BLUE digital input data; bit 0 (LSB)
CLK	31	clock input
V _{DDA1}	32	analog supply voltage 1
V _{REF}	33	decoupling input for reference voltage
n.c.	34	not connected
V _{DDA2}	35	analog supply voltage 2
OUTB	36	BLUE analog output
n.c.	37	not connected
n.c.	38	not connected
V _{DDA3}	39	analog supply voltage 3
OUTG	40	GREEN analog output

Triple 8-bit video Digital-to-Analog Converter (DAC)

TDA8771A

SYMBOL	PIN	DESCRIPTION
n.c.	41	not connected
V _{SSA2}	42	analog supply ground 2
V _{DDA4}	43	analog supply voltage 4
OUTR	44	RED analog output

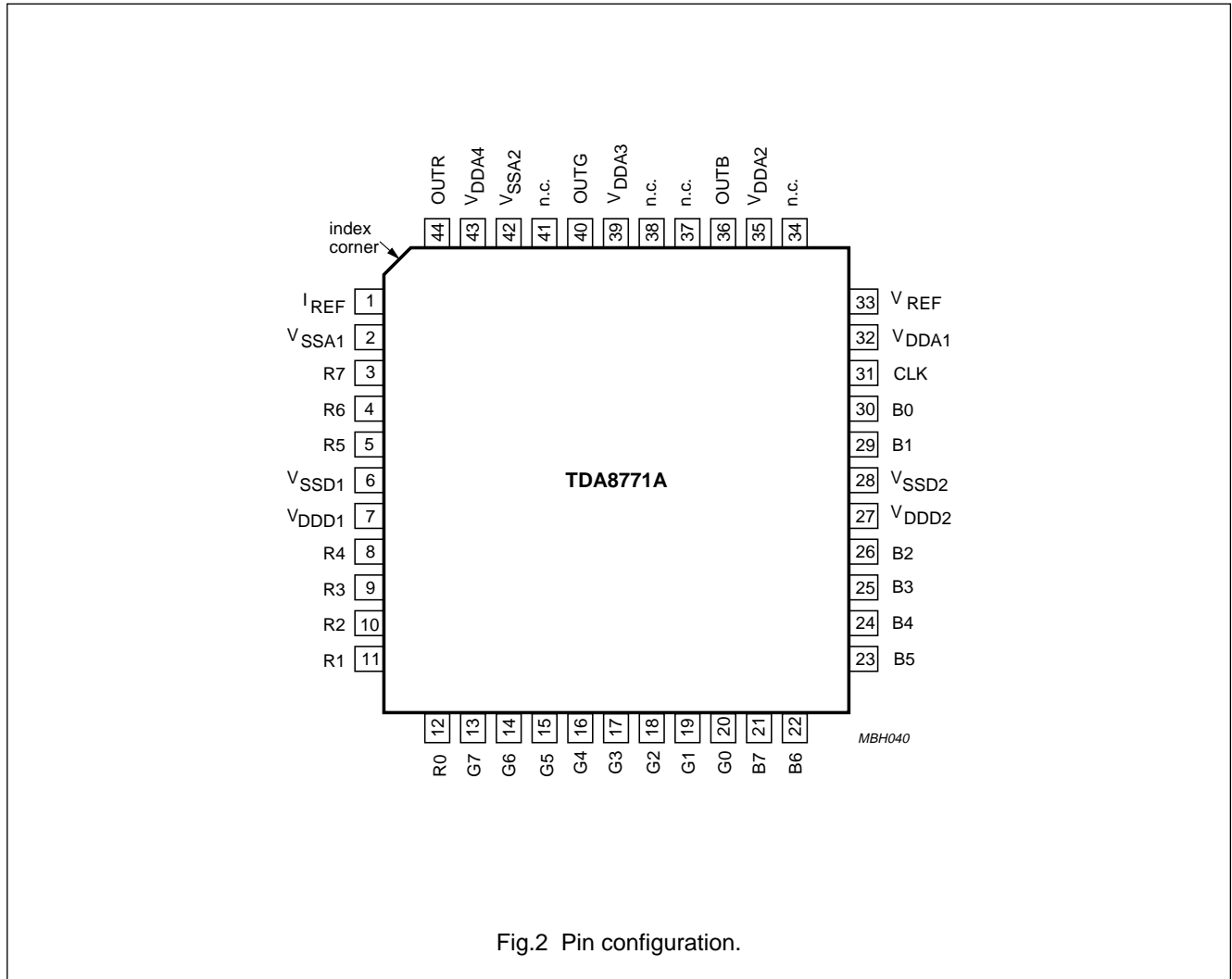

Fig.2 Pin configuration.

Triple 8-bit video Digital-to-Analog Converter (DAC)

TDA8771A

LIMITING VALUES

In accordance with the Absolute Maximum Rating System (IEC134).

SYMBOL	PARAMETER	MIN.	MAX.	UNIT
V_{DDA}	analog supply voltage	-0.5	+6.5	V
V_{DDD}	digital supply voltage	-0.5	+6.5	V
ΔV_{DD}	supply voltage difference between V_{DDA} and V_{DDD}	-1.0	+1.0	V
T_{stg}	storage temperature	-55	+150	°C
T_{amb}	operating ambient temperature	0	+70	°C
T_j	junction temperature	-	+125	°C

THERMAL CHARACTERISTICS

SYMBOL	PARAMETER	VALUE	UNIT
$R_{th\ j-a}$	thermal resistance from junction to ambient in free air	75	K/W

HANDLING

Inputs and outputs are protected against electrostatic discharges in normal handling. However, to be totally safe, it is desirable to take normal precautions appropriate to handling integrated circuits.

Triple 8-bit video Digital-to-Analog Converter (DAC)

TDA8771A

CHARACTERISTICS

$V_{DDA} = V_{DDD} = 4.5$ to 5.5 V; V_{SSA} and V_{SSD} shorted together; $V_{DDA} - V_{DDD} = -0.5$ to $+0.5$ V; $T_{amb} = 0$ to 70 °C; typical values measured at $V_{DDA} = V_{DDD} = 5$ V and $T_{amb} = 25$ °C; unless otherwise specified.

SYMBOL	PARAMETER	CONDITIONS	MIN.	TYP.	MAX.	UNIT
Supply						
V_{DDA}	analog supply voltage		4.5	5.0	5.5	V
V_{DDD}	digital supply voltage		4.5	5.0	5.5	V
I_{DDA}	analog supply current	$R_L = 1$ k Ω ; note 1	10	33	45	mA
I_{DDD}	digital supply current	$f_{clk} = 35$ MHz	–	7	20	mA
Inputs						
CLOCK INPUT (PIN 31)						
V_{IL}	LOW level input voltage		0	–	1.2	V
V_{IH}	HIGH level input voltage		2.0	–	V_{DDD}	V
R, G, B DIGITAL INPUTS (PINS 12 TO 8, 5 TO 3, 20 TO 13, 30, 29 AND 26 TO 21)						
V_{IL}	LOW level input voltage		0	–	1.2	V
V_{IH}	HIGH level input voltage		2.0	–	V_{DDD}	V
I_{REF} REFERENCE CURRENT INPUT FOR OUTPUT BUFFERS (PIN 1)						
I_I	input current		–	0.6	0.7	mA
Timing; see Fig.3						
$f_{clk(max)}$	maximum clock frequency		35	–	–	MHz
t_{CPH}	clock pulse width HIGH		8	–	–	ns
t_{CPL}	clock pulse width LOW		8	–	–	ns
t_r	clock rise time		–	–	5	ns
t_f	clock fall time		–	–	6	ns
$t_{SU;DAT}$	input data set-up time		4	–	–	ns
$t_{HD;DAT}$	input data hold time		4	–	–	ns
Voltage reference (pin 33, referenced to V_{SSA})						
V_{REF}	output reference voltage		1.180	1.242	1.305	V
Outputs						
OUTB, OUTR, OUTG ANALOG OUTPUTS (PINS 36, 44 AND 40, REFERENCED TO V_{SSA}) FOR 1 k Ω LOAD; see Table 1						
FSR	full-scale output voltage range		2.80	2.95	3.10	V
V_{os}	offset of analog voltage output		–	0.25	–	V
V_{Omax}	maximum output voltage	data inputs = logic 1; note 2	2.95	3.20	3.45	V
V_{Omin}	minimum output voltage	data inputs = logic 0; note 2	0.05	0.25	0.45	V
THD	total harmonic distortion	$f_i = 4.43$ MHz; $f_{clk} = 35$ MHz	–	–44	–	dB
Z_L	output load impedance		0.9	1.0	1.1	k Ω

Triple 8-bit video Digital-to-Analog Converter (DAC)

TDA8771A

SYMBOL	PARAMETER	CONDITIONS	MIN.	TYP.	MAX.	UNIT
Transfer function ($f_{clk} = 35$ MHz)						
INL	integral non-linearity	ramp input	–	0.5	± 1	LSB
DNL	differential non-linearity	ramp input	–	0.25	± 0.5	LSB
α_{ct}	crosstalk DAC to DAC		–50	–	–	dB
	DAC to DAC matching		–	1.0	2.0	%
Switching characteristics (for 1 kΩ output load); see Fig.4						
t_d	input to 50% output delay time	full-scale change	–	12	–	ns
t_{s1}	settling time	10% to 90% of full-scale change	–	15	–	ns
t_{s2}	settling time	to ± 1 LSB	–	50	–	ns
Output transients (glitches)						
V_g	area for 1 LSB change		–	1	–	LSB·ns

Notes

1. Minimum and maximum data of current and power consumption are measured in worse case conditions: for minimum data, all digital inputs are at logic level 0 while for maximum data, all digital inputs are at logic level 1.
2. V_O is directly proportional to V_{REF} .

Table 1 Input coding and DAC output voltages (typical values)

BINARY INPUT DATA (SYNC = BLANK = 0)	CODE	DAC OUTPUT VOLTAGES (V) OUTB, OUTR, OUTG $R_L = 1$ k Ω
0000 0000	0	0.262
0000 0001	1	0.273
....
1000 0000	128	1.731
....
1111 1110	254	3.188
1111 1111	255	3.200

Triple 8-bit video Digital-to-Analog Converter (DAC)

TDA8771A

TIMING

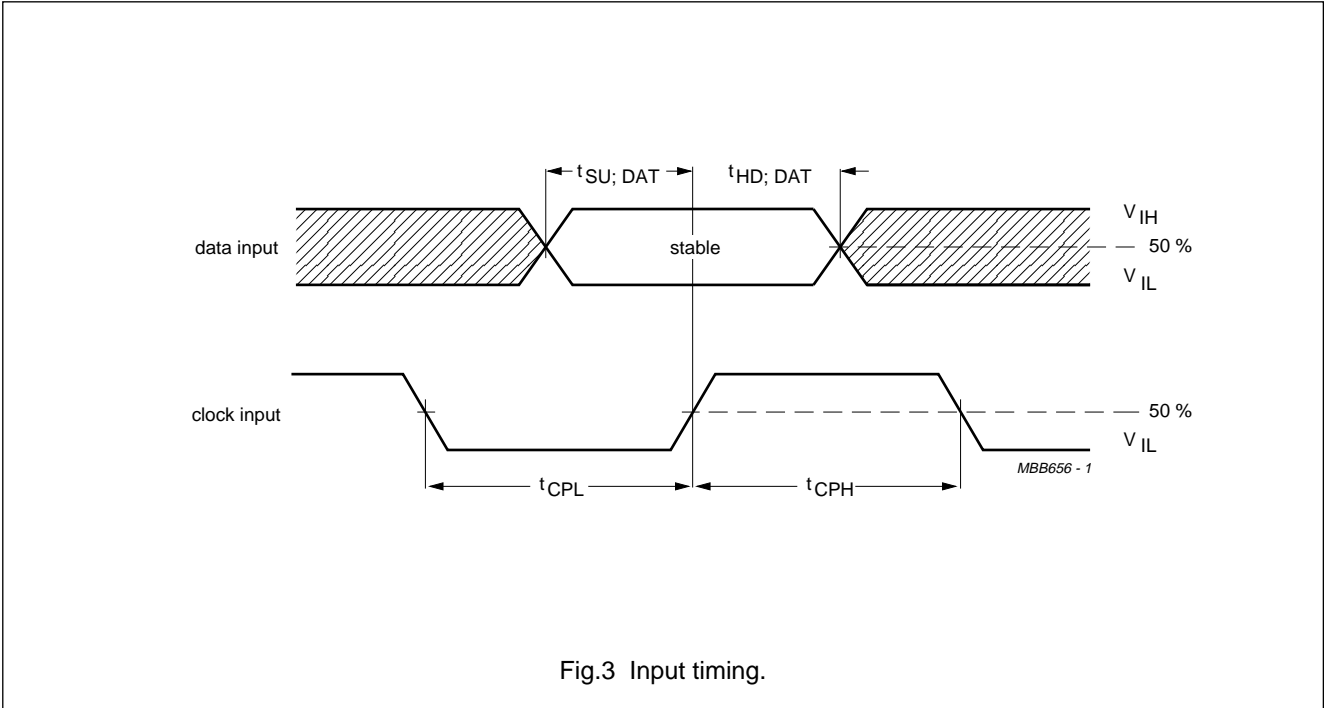

Fig.3 Input timing.

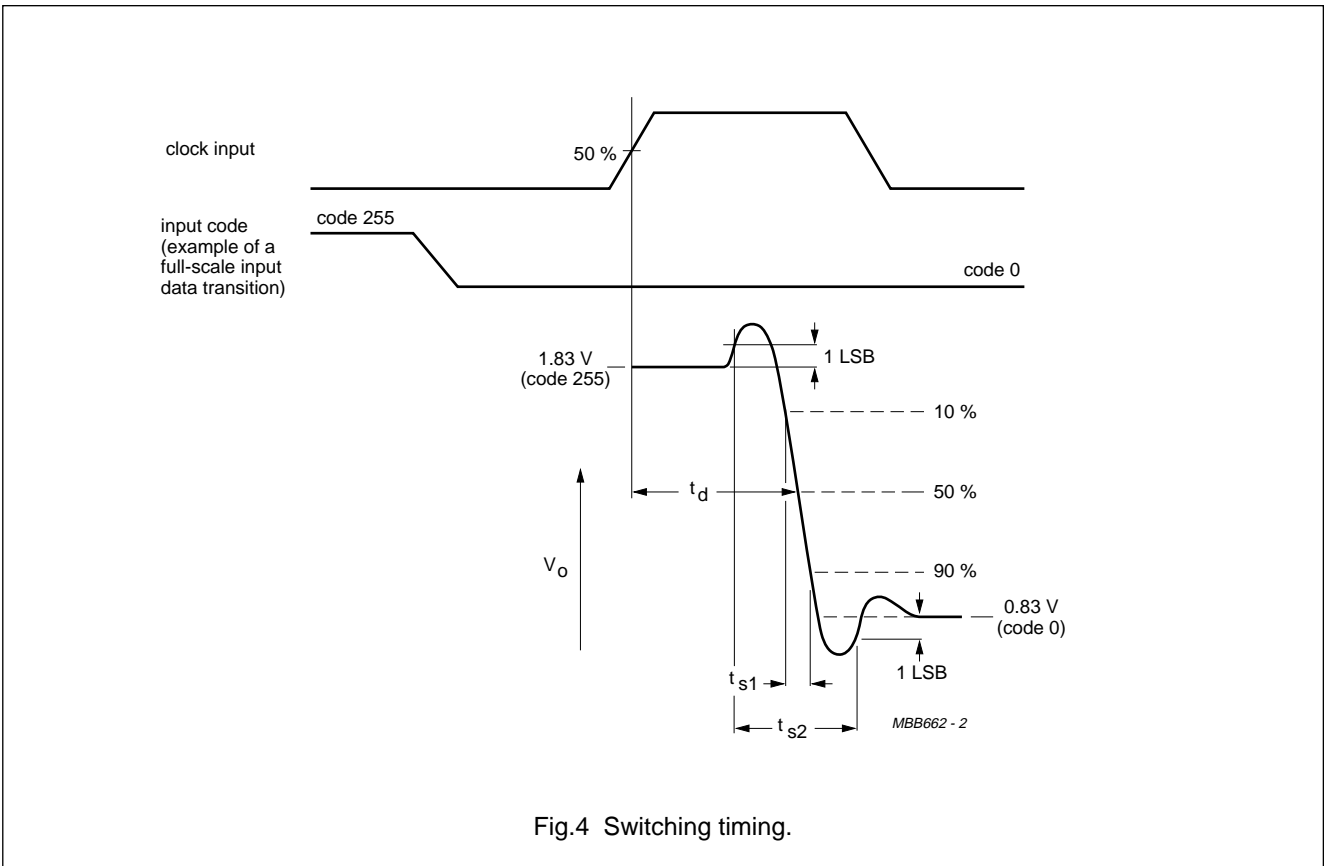
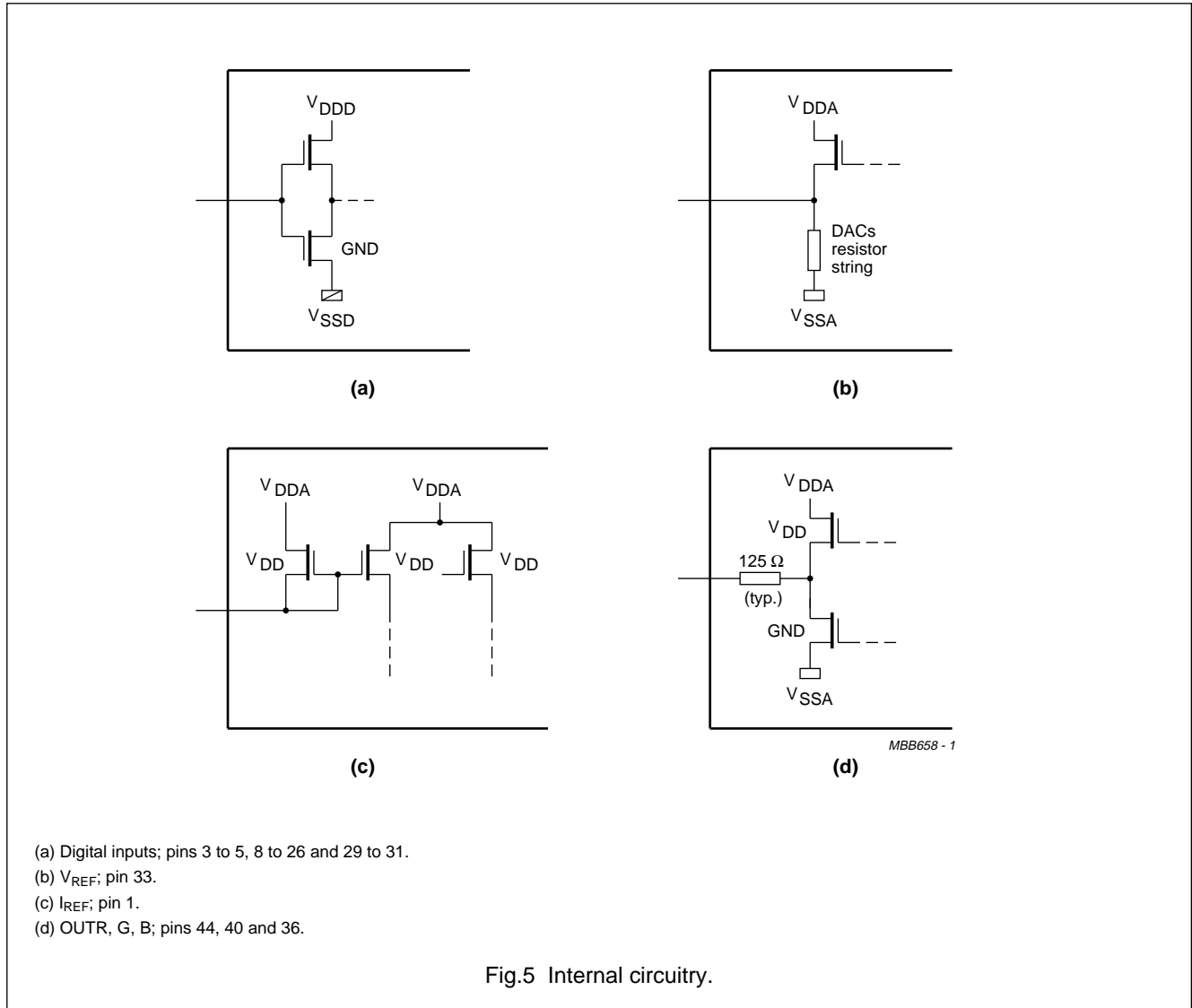

Fig.4 Switching timing.

Triple 8-bit video Digital-to-Analog Converter (DAC)

TDA8771A

INTERNAL CIRCUITRY



- (a) Digital inputs; pins 3 to 5, 8 to 26 and 29 to 31.
- (b) V_{REF} ; pin 33.
- (c) I_{REF} ; pin 1.
- (d) OUTR, G, B; pins 44, 40 and 36.

Fig.5 Internal circuitry.

Triple 8-bit video Digital-to-Analog Converter (DAC)

TDA8771A

APPLICATION INFORMATION

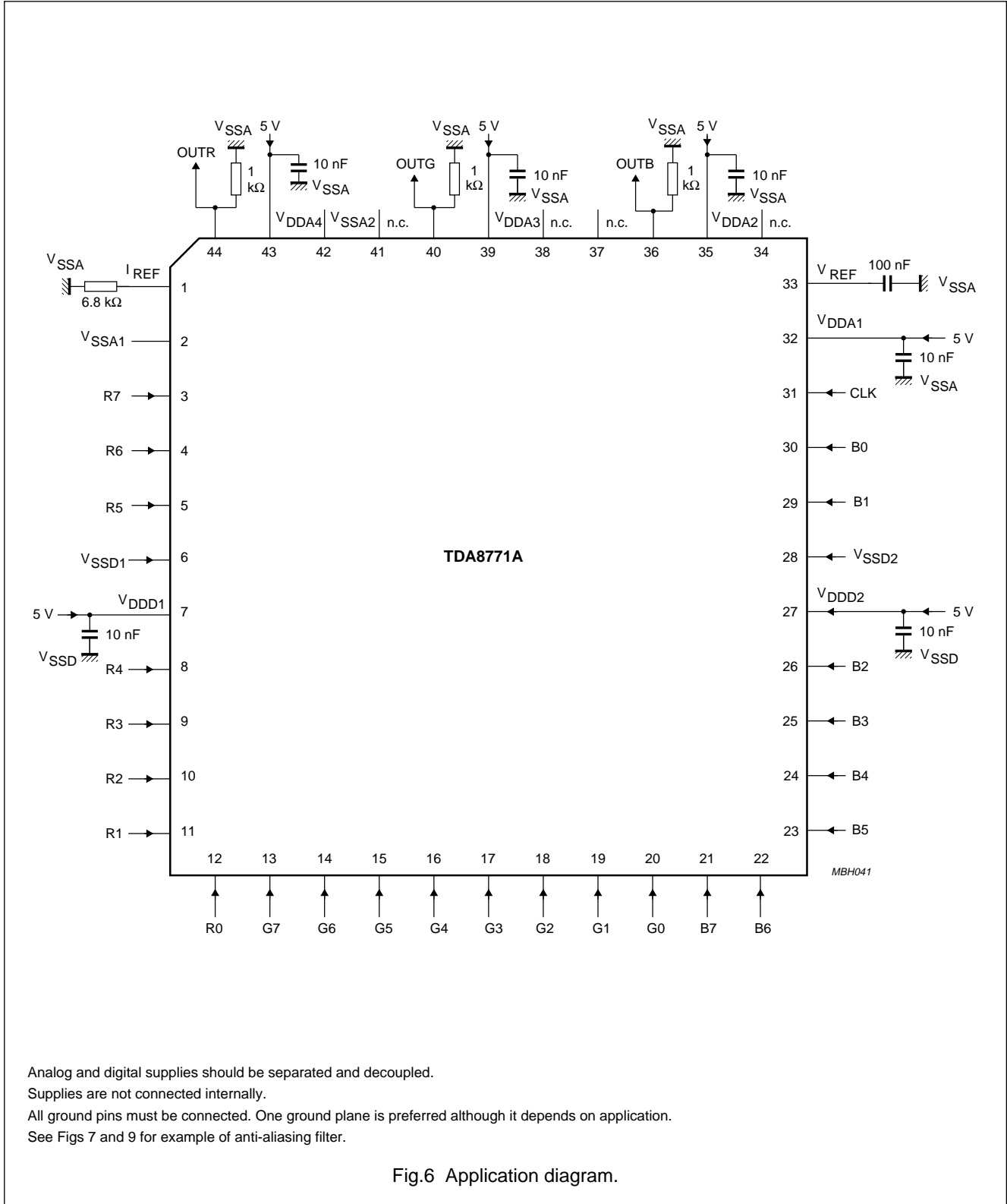

Analog and digital supplies should be separated and decoupled.
 Supplies are not connected internally.
 All ground pins must be connected. One ground plane is preferred although it depends on application.
 See Figs 7 and 9 for example of anti-aliasing filter.

Fig.6 Application diagram.

Triple 8-bit video Digital-to-Analog Converter (DAC)

TDA8771A

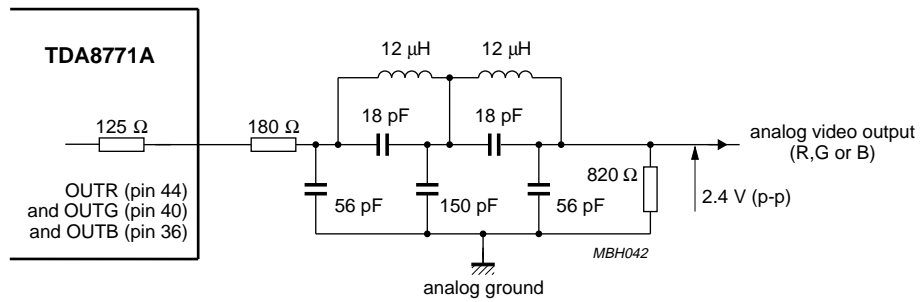

Fig.7 Example of anti-aliasing filter for 2.4 V output swing.

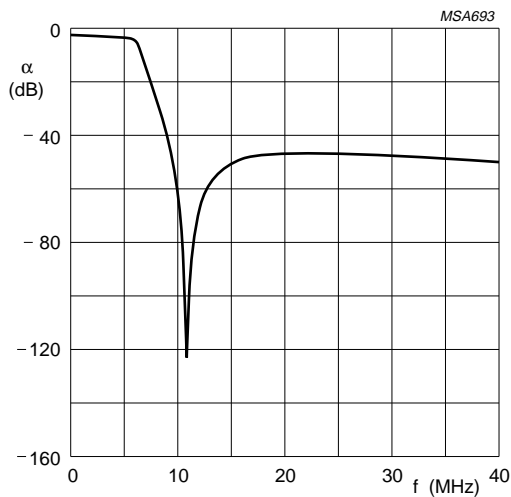

Fig.8 Frequency response for filter shown in Fig.7.

Characteristics of Fig.8

- Order 5; adapted CHEBYSHEV
- Ripple $\rho \geq 0.7$ dB
- f at -3 dB = 6.2 MHz
- $f_{\text{NOTCH}} = 10.8$ MHz.

Triple 8-bit video Digital-to-Analog Converter (DAC)

TDA8771A

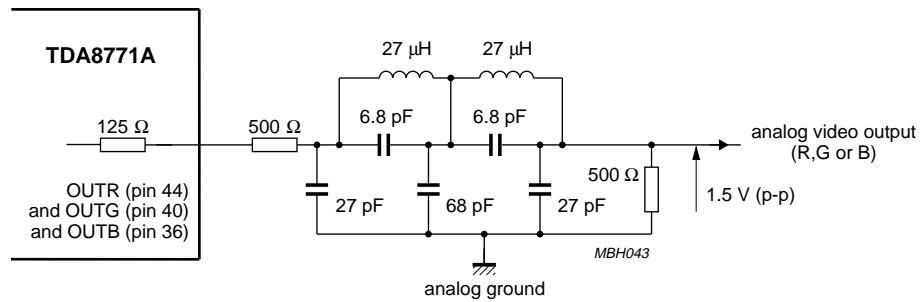

Fig.9 Example of anti-aliasing filter for 1.5 V output swing.

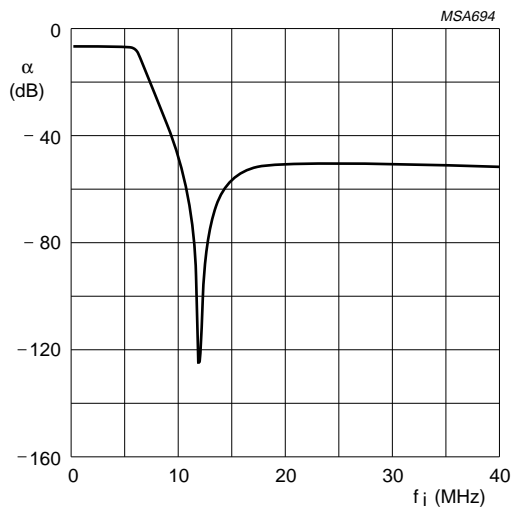

Fig.10 Frequency response for filter shown in Fig.9.

Characteristics of Fig.10

- Order 5; adapted CHEBYSHEV
- Ripple $\rho \geq 0.25$ dB
- f at -3 dB = 5.6 MHz
- $f_{\text{NOTCH}} = 11.7$ MHz.

Triple 8-bit video Digital-to-Analog Converter (DAC)

TDA8771A

PACKAGE OUTLINE

QFP44: plastic quad flat package; 44 leads (lead length 1.3 mm); body 10 x 10 x 1.75 mm

SOT307-2

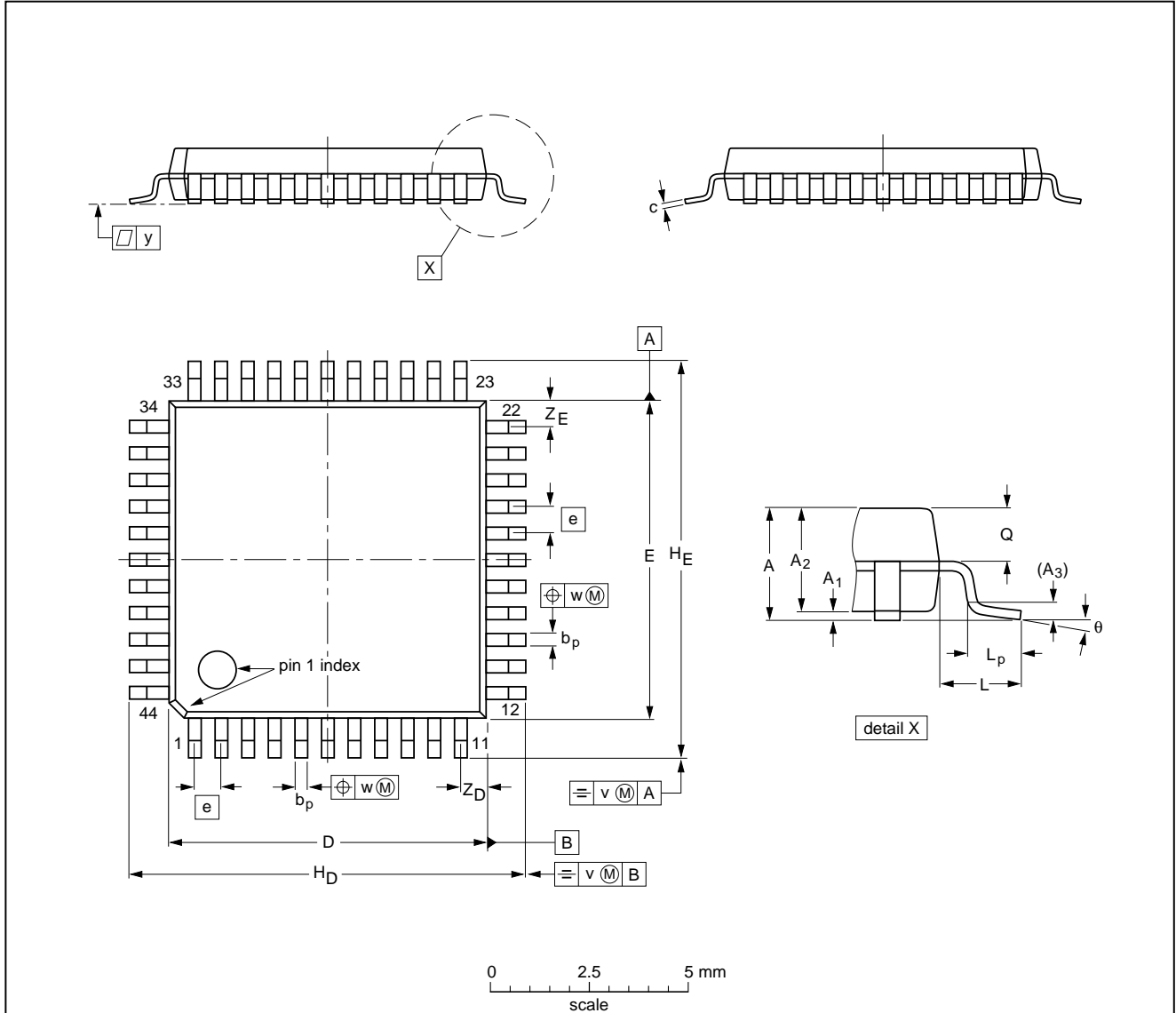

DIMENSIONS (mm are the original dimensions)

UNIT	A max.	A ₁	A ₂	A ₃	b _p	c	D ⁽¹⁾	E ⁽¹⁾	e	H _D	H _E	L	L _p	Q	v	w	y	Z _D ⁽¹⁾	Z _E ⁽¹⁾	θ
mm	2.10	0.25 0.05	1.85 1.65	0.25	0.40 0.20	0.25 0.14	10.1 9.9	10.1 9.9	0.8	12.9 12.3	12.9 12.3	1.3	0.95 0.55	0.85 0.75	0.15	0.15	0.1	1.2 0.8	1.2 0.8	10° 0°

Note

1. Plastic or metal protrusions of 0.25 mm maximum per side are not included.

OUTLINE VERSION	REFERENCES				EUROPEAN PROJECTION	ISSUE DATE
	IEC	JEDEC	EIAJ			
SOT307-2						92-11-17 95-02-04

Triple 8-bit video Digital-to-Analog Converter (DAC)

TDA8771A

SOLDERING

Introduction

There is no soldering method that is ideal for all IC packages. Wave soldering is often preferred when through-hole and surface mounted components are mixed on one printed-circuit board. However, wave soldering is not always suitable for surface mounted ICs, or for printed-circuits with high population densities. In these situations reflow soldering is often used.

This text gives a very brief insight to a complex technology. A more in-depth account of soldering ICs can be found in our *"IC Package Databook"* (order code 9398 652 90011).

Reflow soldering

Reflow soldering techniques are suitable for all QFP packages.

The choice of heating method may be influenced by larger plastic QFP packages (44 leads, or more). If infrared or vapour phase heating is used and the large packages are not absolutely dry (less than 0.1% moisture content by weight), vaporization of the small amount of moisture in them can cause cracking of the plastic body. For more information, refer to the Drypack chapter in our *"Quality Reference Handbook"* (order code 9397 750 00192).

Reflow soldering requires solder paste (a suspension of fine solder particles, flux and binding agent) to be applied to the printed-circuit board by screen printing, stencilling or pressure-syringe dispensing before package placement.

Several techniques exist for reflowing; for example, thermal conduction by heated belt. Dwell times vary between 50 and 300 seconds depending on heating method. Typical reflow temperatures range from 215 to 250 °C.

Preheating is necessary to dry the paste and evaporate the binding agent. Preheating duration: 45 minutes at 45 °C.

Wave soldering

Wave soldering is **not** recommended for QFP packages. This is because of the likelihood of solder bridging due to closely-spaced leads and the possibility of incomplete solder penetration in multi-lead devices.

If wave soldering cannot be avoided, the following conditions must be observed:

- **A double-wave (a turbulent wave with high upward pressure followed by a smooth laminar wave) soldering technique should be used.**
- **The footprint must be at an angle of 45° to the board direction and must incorporate solder thieves downstream and at the side corners.**

Even with these conditions, do not consider wave soldering the following packages: QFP52 (SOT379-1), QFP100 (SOT317-1), QFP100 (SOT317-2), QFP100 (SOT382-1) or QFP160 (SOT322-1).

During placement and before soldering, the package must be fixed with a droplet of adhesive. The adhesive can be applied by screen printing, pin transfer or syringe dispensing. The package can be soldered after the adhesive is cured.

Maximum permissible solder temperature is 260 °C, and maximum duration of package immersion in solder is 10 seconds, if cooled to less than 150 °C within 6 seconds. Typical dwell time is 4 seconds at 250 °C.

A mildly-activated flux will eliminate the need for removal of corrosive residues in most applications.

Repairing soldered joints

Fix the component by first soldering two diagonally-opposite end leads. Use only a low voltage soldering iron (less than 24 V) applied to the flat part of the lead. Contact time must be limited to 10 seconds at up to 300 °C. When using a dedicated tool, all other leads can be soldered in one operation within 2 to 5 seconds between 270 and 320 °C.

Triple 8-bit video Digital-to-Analog Converter (DAC)

TDA8771A

DEFINITIONS

Data sheet status	
Objective specification	This data sheet contains target or goal specifications for product development.
Preliminary specification	This data sheet contains preliminary data; supplementary data may be published later.
Product specification	This data sheet contains final product specifications.
Limiting values	
Limiting values given are in accordance with the Absolute Maximum Rating System (IEC 134). Stress above one or more of the limiting values may cause permanent damage to the device. These are stress ratings only and operation of the device at these or at any other conditions above those given in the Characteristics sections of the specification is not implied. Exposure to limiting values for extended periods may affect device reliability.	
Application information	
Where application information is given, it is advisory and does not form part of the specification.	

LIFE SUPPORT APPLICATIONS

These products are not designed for use in life support appliances, devices, or systems where malfunction of these products can reasonably be expected to result in personal injury. Philips customers using or selling these products for use in such applications do so at their own risk and agree to fully indemnify Philips for any damages resulting from such improper use or sale.