

TDA8942P

2 x 1.5 W stereo Bridge Tied Load (BTL) audio amplifier

14 April 1999

Preliminary specification

1. Description

The TDA8942P is a dual-channel audio power amplifier for an output power of $2 \times 1.5 \text{ W}$ at a 16Ω load and a 9 V supply. The circuit contains two Bridge Tied Load (BTL) amplifiers with an all-NPN output stage and standby/mute logic. The TDA8942P comes in a 16-pin dual in-line (DIP) package. The TDA8942P is printed-circuit board (PCB) compatible with all other types in the TDA894x family. One PCB footprint accommodates both the mono and the stereo products.

2. Features

- Few external components
- Fixed gain
- Standby and mute mode
- No on/off switching plops
- Low standby current
- High supply voltage ripple rejection
- Outputs short-circuit safe to ground, supply and across the load
- Thermally protected
- Printed-circuit board compatible, see [Table 3 "Product family overview"](#).

3. Applications

- Mains fed applications (e.g. TV sound)
- PC audio
- Portable audio.

4. Quick reference data

Table 1: Quick reference data

Symbol	Parameter	Conditions	Min	Typ	Max	Unit
V_{CC}	supply voltage		6	9	18	V
I_q	quiescent supply current	$V_{CC} = 9 \text{ V}; R_L = \infty$	-	22	32	mA
I_{stb}	standby supply current		-	-	10	μA



PHILIPS

Table 1: Quick reference data...continued

Symbol	Parameter	Conditions	Min	Typ	Max	Unit
P_o	output power	THD = 10%; $R_L = 16 \Omega$; $V_{CC} = 9 V$	1.2	1.5	-	W
THD	total harmonic distortion	$P_o = 0.5 W$	-	0.03	0.1	%
G_v	voltage gain		31	32	33	dB
SVRR	supply voltage ripple rejection		50	-	-	dB

5. Ordering information

Table 2: Ordering information

Type number	Package		
	Name	Description	Version
TDA8942P	DIP16	plastic dual in-line package; 16 leads (300 mil); long body	SOT38-1

5.1 Ordering options

Table 3: Product family overview

Type number	Package	Description
TDA8941P	DIP8	1.5 W mono Bridge Tied Load (BTL) audio amplifier
TDA8942P	DIP16	2 x 1.5 W stereo Bridge Tied Load (BTL) audio amplifier
TDA8943SF	SIL9MPF	7 W mono Bridge Tied Load (BTL) audio amplifier
TDA8944J	DBS17P	2 x 7 W stereo Bridge Tied Load (BTL) audio amplifier
TDA8945S	SIL9P	15 W mono Bridge Tied Load (BTL) audio amplifier
TDA8946J	DBS17P	2 x 15 W stereo Bridge Tied Load (BTL) audio amplifier

6. Block diagram

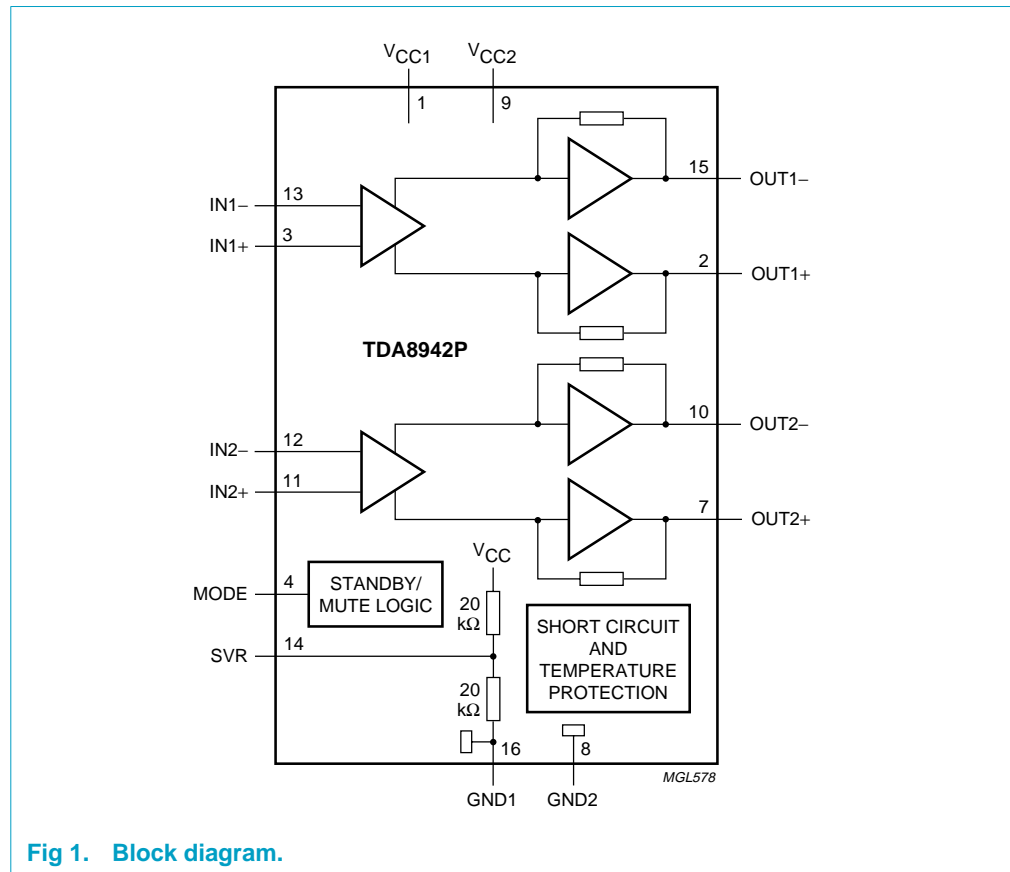

Fig 1. Block diagram.

7. Pinning information

7.1 Pinning

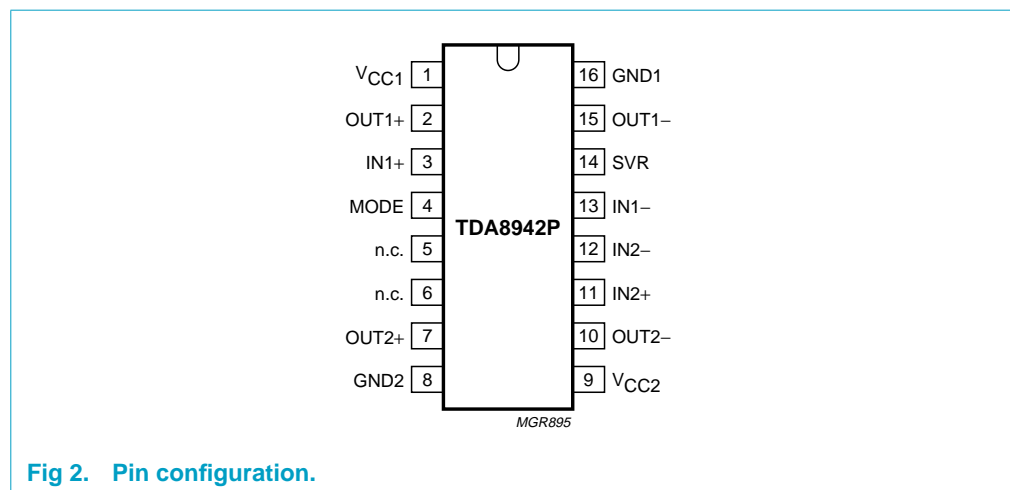

Fig 2. Pin configuration.

7.2 Pin description

Table 4: Pin description

Symbol	Pin	Description
V _{CC1}	1	supply voltage channel 1
OUT1+	2	positive loudspeaker terminal 1
IN1+	3	positive input 1
MODE	4	mode selection input (standby, mute, operating)
n.c.	5	not connected
n.c.	6	not connected
OUT2+	7	positive loudspeaker terminal 2
GND2	8	ground channel 2
V _{CC2}	9	supply voltage channel 2
OUT2-	10	negative loudspeaker terminal 2
IN2+	11	positive input 2
IN2-	12	negative input 2
IN1-	13	negative input 1
SVR	14	half supply voltage decoupling (ripple rejection)
OUT1-	15	negative loudspeaker terminal 1
GND1	16	ground channel 1

8. Functional description

The TDA8942P is a stereo BTL audio power amplifier capable of delivering 2×1.5 W output power to a 16 Ω load at THD = 10%, using a 9 V power supply. The voltage gain is fixed at 32 dB.

With the three-level MODE input the device can be switched from 'standby' to 'mute' and to 'operating' mode.

The TDA8942P outputs are protected by an internal thermal shutdown protection mechanism and a short-circuit protection.

8.1 Power amplifier

The power amplifier is a Bridge Tied Load (BTL) amplifier with an all-NPN output stage, capable of delivering peak output current of 1.5 A.

The BTL principle offers the following advantages:

- Lower peak value of the supply current
- The frequency of the ripple on the supply voltage is twice the signal frequency
- No expensive DC-blocking capacitors
- Good low frequency performance.

8.2 Mode selection

The TDA8942P has three functional modes, which can be selected by applying the proper DC voltage to pin MODE.

Standby — In this mode the current consumption is very low and the outputs are floating. The device is in standby mode when $V_{MODE} > (V_{CC} - 0.5 \text{ V})$, or when the MODE pin is left floating.

Mute — In this mode the amplifier is DC-biased but not operational (no audio output). This allows the input coupling capacitors to be charged to avoid pop-noise. The device is in mute mode when $2.5 \text{ V} < V_{MODE} < (V_{CC} - 1.5 \text{ V})$.

Operating — In this mode the amplifier is operating normally. The operating mode is activated at $V_{MODE} < 0.5 \text{ V}$.

9. Limiting values

Table 5: Limiting values

In accordance with the Absolute Maximum Rating System (IEC 60134).

Symbol	Parameter	Conditions	Min	Max	Unit
V_{CC}	supply voltage	operating	-0.3	+18	V
		no signal	[1] -0.3	+25	V
V_I	input voltage		-0.3	$V_{CC} + 0.3$	V
I_{ORM}	repetitive peak output current		-	2	A
T_{stg}	storage temperature	non-operating	-55	+150	°C
T_{amb}	operating ambient temperature		-40	+85	°C
P_{tot}	total power dissipation		-	<tbf>	W
$V_{CC(sc)}$	supply voltage to guarantee short-circuit protection		-	<tbf>	V

[1] Applies to all functional modes.

10. Thermal characteristics

Table 6: Thermal characteristics

Symbol	Parameter	Conditions	Value	Unit
$R_{th(j-a)}$	thermal resistance from junction to ambient	in free air	55	K/W

11. Static characteristics

Table 7: Static characteristics

$V_{CC} = 9 \text{ V}$; $T_{amb} = 25 \text{ °C}$; $R_L = 16 \text{ } \Omega$; $V_{MODE} = 0 \text{ V}$; $V_i = 0 \text{ V}$; measured in test circuit [Figure 3](#); unless otherwise specified.

Symbol	Parameter	Conditions	Min	Typ	Max	Unit
V_{CC}	supply voltage	operating	6	9	18	V
I_q	quiescent current	$R_L = \infty$	[1] -	22	32	mA
I_{stb}	standby current	$V_{MODE} = V_{CC}$	-	-	10	μA
V_O	DC output voltage		[2] -	4.5	-	V

Table 7: Static characteristics...continued

$V_{CC} = 9\text{ V}$; $T_{amb} = 25\text{ °C}$; $R_L = 16\text{ }\Omega$; $V_{MODE} = 0\text{ V}$; $V_i = 0\text{ V}$; measured in test circuit **Figure 3**; unless otherwise specified.

Symbol	Parameter	Conditions	Min	Typ	Max	Unit
ΔV_{OUT} [3]	differential output voltage offset		-	-	200	mV
V_{MODE}	input voltage mode select	operating mode	0	-	0.5	V
		mute mode	2.5	-	$V_{CC} - 1.5$	V
		standby mode	$V_{CC} - 0.5$	-	V_{CC}	V
I_{MODE}	input current mode select	$0 < V_{MODE} < V_{CC}$	-	-	20	μA

- [1] With a load connected at the outputs the quiescent current will increase, the maximum of this increase being equal to the differential output voltage offset (ΔV_{OUT}) divided by the load resistance (R_L).
- [2] The DC output voltage with respect to ground is approximately $0.5V_{CC}$.
- [3] $\Delta V_{OUT} = |V_{OUT+} - V_{OUT-}|$.

12. Dynamic characteristics

Table 8: Dynamic characteristics

$V_{CC} = 9\text{ V}$; $T_{amb} = 25\text{ °C}$; $R_L = 16\text{ }\Omega$; $f = 1\text{ kHz}$; $V_{MODE} = 0\text{ V}$; measured in test circuit **Figure 3**; unless otherwise specified.

Symbol	Parameter	Conditions	Min	Typ	Max	Unit
P_o	output power	THD = 10%	1.2	1.5	-	W
		THD = 0.5%	0.8	1	-	W
THD	total harmonic distortion	$P_o = 0.5\text{ W}$	-	0.03	0.1	%
G_v	voltage gain		31	32	33	dB
$Z_{i(dif)}$	differential input impedance		70	90	110	$\text{k}\Omega$
$V_{n(o)}$	noise output voltage		[1] -	90	120	μV
SVRR	supply voltage ripple rejection	$f_{ripple} = 1\text{ kHz}$	[2] 50	-	-	dB
		$f_{ripple} = 100\text{ Hz to }20\text{ kHz}$	[2] -	<tbf>	-	dB
$V_{o(mute)}$	output voltage	mute mode	[3] -	-	50	μV
α_{cs}	channel separation	$R_{source} = <tbf>$	50	-	-	dB

- [1] The noise output voltage is measured at the output in a frequency range from 20 Hz to 20 kHz (unweighted), with a source impedance $R_{source} = 0\text{ }\Omega$ at the input.
- [2] Supply voltage ripple rejection is measured at the output, with a source impedance $R_{source} = 0\text{ }\Omega$ at the input. The ripple voltage is a sine wave with a frequency f_{ripple} and an amplitude of 100 mV (RMS), which is applied to the positive supply rail.
- [3] Output voltage in mute mode is measured with an input voltage of 1 V (RMS) in a bandwidth of 20 kHz, so including noise.

13. Application information

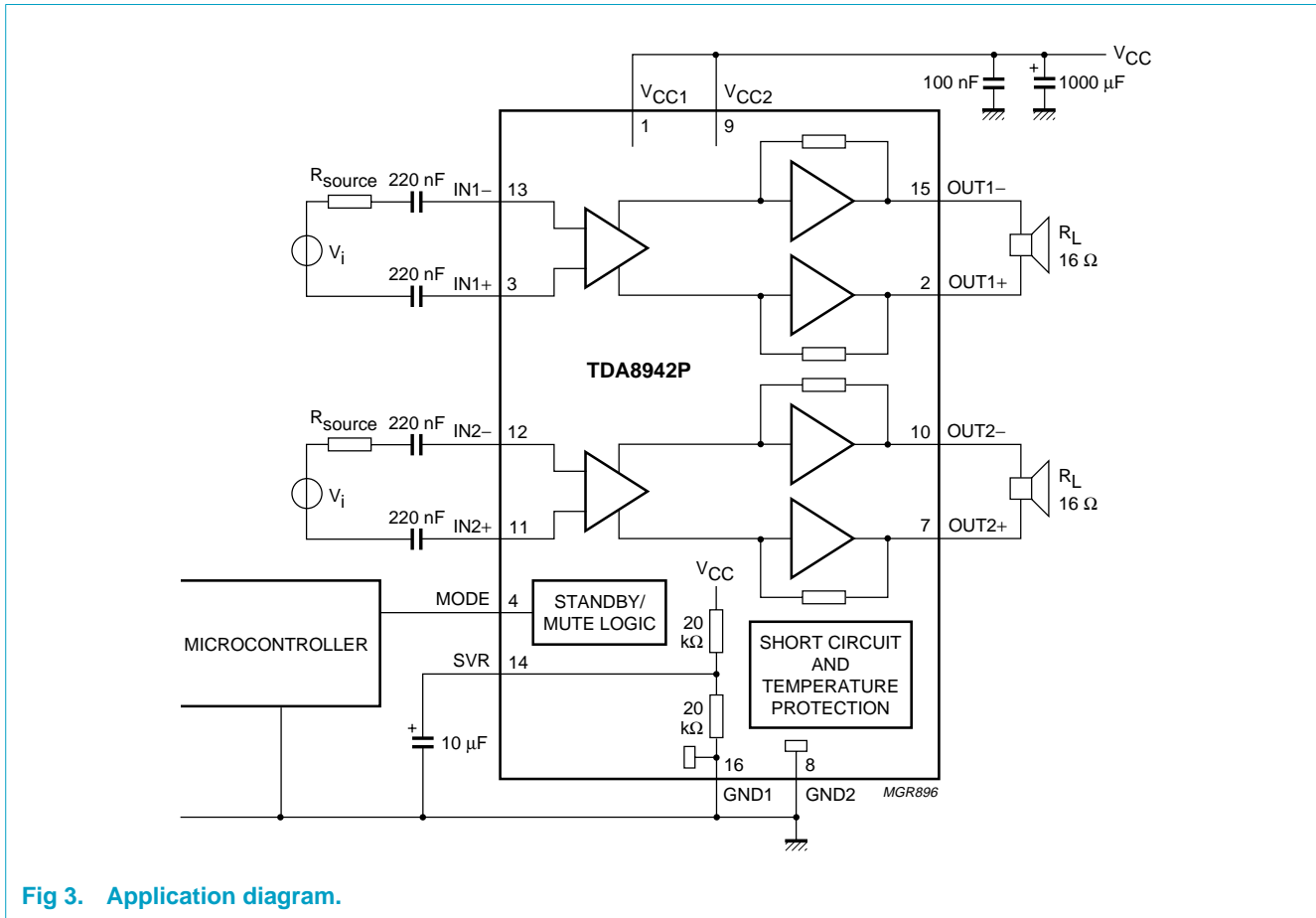

Fig 3. Application diagram.

14. Test information

14.1 Quality information

The *General Quality Specification for Integrated Circuits, SNW-FQ-611-part E* is applicable and reference can be found in the *Quality Reference Handbook, chapter Quality standards for customers*. The handbook can be ordered using the code 9397 750 00192.

15. Package outline

DIP16: plastic dual in-line package; 16 leads (300 mil); long body

SOT38-1

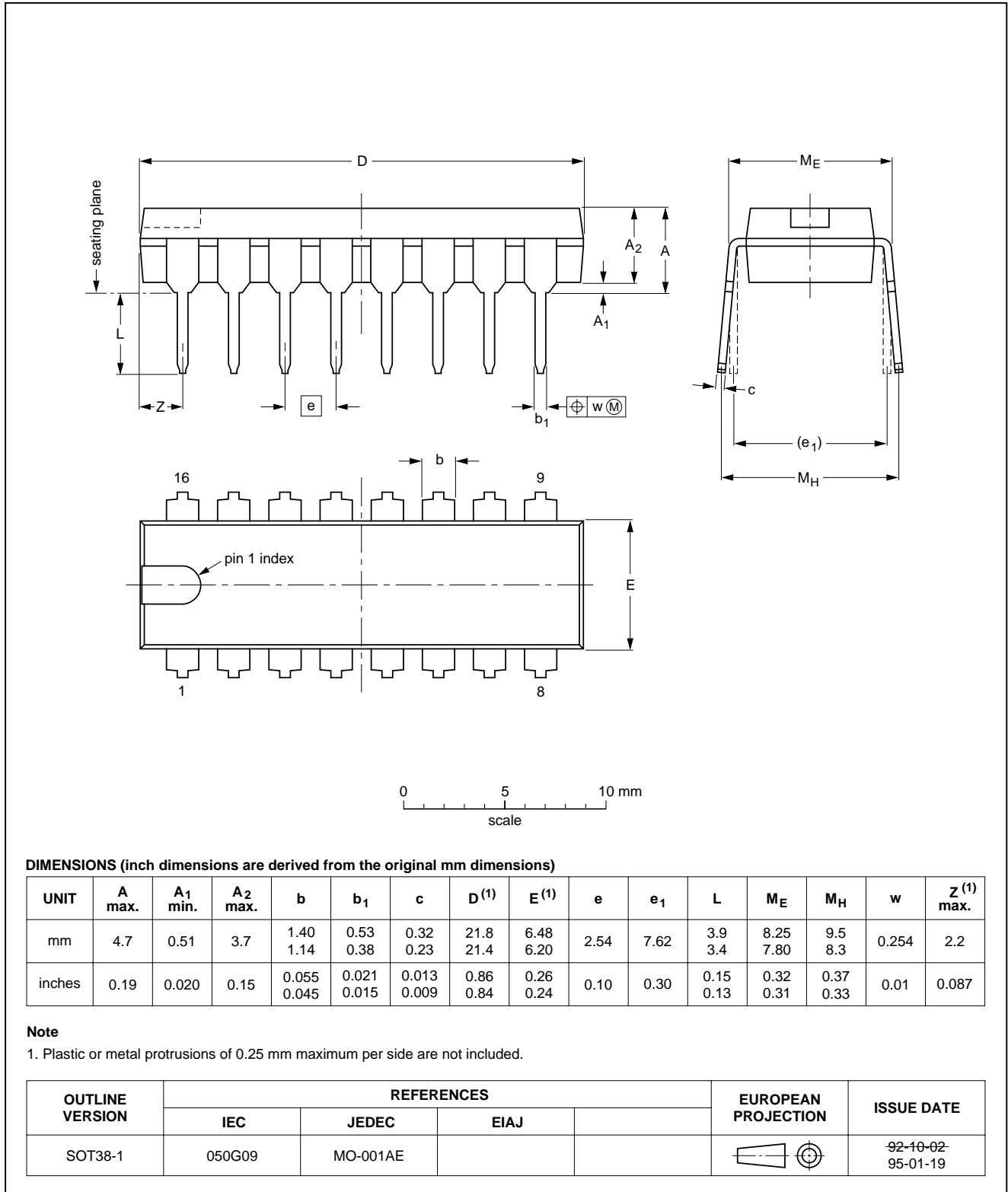

Fig 4. DIP16 package outline.

16. Soldering

16.1 Introduction to soldering through-hole mount packages

This text gives a brief insight to wave, dip and manual soldering. A more in-depth account of soldering ICs can be found in our *Data Handbook IC26; Integrated Circuit Packages* (document order number 9398 652 90011).

Wave soldering is the preferred method for mounting of through-hole mount IC packages on a printed-circuit board.

16.2 Soldering by dipping or by solder wave

The maximum permissible temperature of the solder is 260 °C; solder at this temperature must not be in contact with the joints for more than 5 seconds. The total contact time of successive solder waves must not exceed 5 seconds.

The device may be mounted up to the seating plane, but the temperature of the plastic body must not exceed the specified maximum storage temperature ($T_{stg(max)}$). If the printed-circuit board has been pre-heated, forced cooling may be necessary immediately after soldering to keep the temperature within the permissible limit.

16.3 Manual soldering

Apply the soldering iron (24 V or less) to the lead(s) of the package, either below the seating plane or not more than 2 mm above it. If the temperature of the soldering iron bit is less than 300 °C it may remain in contact for up to 10 seconds. If the bit temperature is between 300 and 400 °C, contact may be up to 5 seconds.

16.4 Package related soldering information

Table 9: Suitability of through-hole mount IC packages for dipping and wave soldering methods

Package	Soldering method	
	Dipping	Wave
DBS, DIP, HDIP, SDIP, SIL	suitable	suitable ^[1]

[1] For SDIP packages, the longitudinal axis must be parallel to the transport direction of the printed-circuit board.

17. Revision history

Rev	Date	CPCN	Description
01	990414	-	Preliminary specification; initial version.

18. Data sheet status

Datasheet status	Product status	Definition ^[1]
Objective specification	Development	This data sheet contains the design target or goal specifications for product development. Specification may change in any manner without notice.
Preliminary specification	Qualification	This data sheet contains preliminary data, and supplementary data will be published at a later date. Philips Semiconductors reserves the right to make changes at any time without notice in order to improve design and supply the best possible product.
Product specification	Production	This data sheet contains final specifications. Philips Semiconductors reserves the right to make changes at any time without notice in order to improve design and supply the best possible product.

[1] Please consult the most recently issued data sheet before initiating or completing a design.

19. Definitions

Short-form specification — The data in a short-form specification is extracted from a full data sheet with the same type number and title. For detailed information see the relevant data sheet or data handbook.

Limiting values definition — Limiting values given are in accordance with the Absolute Maximum Rating System (IEC 60134). Stress above one or more of the limiting values may cause permanent damage to the device. These are stress ratings only and operation of the device at these or at any other conditions above those given in the Characteristics sections of the specification is not implied. Exposure to limiting values for extended periods may affect device reliability.

Application information — Applications that are described herein for any of these products are for illustrative purposes only. Philips Semiconductors make no representation or warranty that such applications will be suitable for the specified use without further testing or modification.

20. Disclaimers

Life support — These products are not designed for use in life support appliances, devices, or systems where malfunction of these products can reasonably be expected to result in personal injury. Philips Semiconductors customers using or selling these products for use in such applications do so at their own risk and agree to fully indemnify Philips Semiconductors for any damages resulting from such application.

Right to make changes — Philips Semiconductors reserves the right to make changes, without notice, in the products, including circuits, standard cells, and/or software, described or contained herein in order to improve design and/or performance. Philips Semiconductors assumes no responsibility or liability for the use of any of these products, conveys no licence or title under any patent, copyright, or mask work right to these products, and makes no representations or warranties that these products are free from patent, copyright, or mask work right infringement, unless otherwise specified.

Philips Semiconductors - a worldwide company

Argentina: see South America

Australia: Tel. +61 29 805 4455, Fax. +61 29 805 4466

Austria: Tel. +43 160 101, Fax. +43 160 101 1210

Belarus: Tel. +375 17 220 0733, Fax. +375 17 220 0773

Belgium: see The Netherlands

Brazil: see South America

Bulgaria: Tel. +359 268 9211, Fax. +359 268 9102

Canada: Tel. +1 800 234 7381

China/Hong Kong: Tel. +852 2 319 7888, Fax. +852 2 319 7700

Colombia: see South America

Czech Republic: see Austria

Denmark: Tel. +45 3 288 2636, Fax. +45 3 157 0044

Finland: Tel. +358 961 5800, Fax. +358 96 158 0920

France: Tel. +33 14 099 6161, Fax. +33 14 099 6427

Germany: Tel. +49 40 23 5360, Fax. +49 402 353 6300

Hungary: see Austria

India: Tel. +91 22 493 8541, Fax. +91 22 493 8722

Indonesia: see Singapore

Ireland: Tel. +353 17 64 0000, Fax. +353 17 64 0200

Israel: Tel. +972 36 45 0444, Fax. +972 36 49 1007

Italy: Tel. +39 26 752 2531, Fax. +39 26 752 2557

Japan: Tel. +81 33 740 5130, Fax. +81 33 740 5077

Korea: Tel. +82 27 09 1412, Fax. +82 27 09 1415

Malaysia: Tel. +60 37 50 5214, Fax. +60 37 57 4880

Mexico: Tel. +9-5 800 234 7381

Middle East: see Italy

For all other countries apply to: Philips Semiconductors,
Marketing & Sales Communications,
Building BE, P.O. Box 218, 5600 MD EINDHOVEN,
The Netherlands, Fax. +31 40 272 4825

Netherlands: Tel. +31 40 278 2785, Fax. +31 40 278 8399

New Zealand: Tel. +64 98 49 4160, Fax. +64 98 49 7811

Norway: Tel. +47 22 74 8000, Fax. +47 22 74 8341

Philippines: Tel. +63 28 16 6380, Fax. +63 28 17 3474

Poland: Tel. +48 22 612 2831, Fax. +48 22 612 2327

Portugal: see Spain

Romania: see Italy

Russia: Tel. +7 095 755 6918, Fax. +7 095 755 6919

Singapore: Tel. +65 350 2538, Fax. +65 251 6500

Slovakia: see Austria

Slovenia: see Italy

South Africa: Tel. +27 11 470 5911, Fax. +27 11 470 5494

South America: Tel. +55 11 821 2333, Fax. +55 11 829 1849

Spain: Tel. +34 33 01 6312, Fax. +34 33 01 4107

Sweden: Tel. +46 86 32 2000, Fax. +46 86 32 2745

Switzerland: Tel. +41 14 88 2686, Fax. +41 14 81 7730

Taiwan: Tel. +886 22 134 2865, Fax. +886 22 134 2874

Thailand: Tel. +66 27 45 4090, Fax. +66 23 98 0793

Turkey: Tel. +90 212 279 2770, Fax. +90 212 282 6707

Ukraine: Tel. +380 44 264 2776, Fax. +380 44 268 0461

United Kingdom: Tel. +44 181 730 5000, Fax. +44 181 754 8421

United States: Tel. +1 800 234 7381

Uruguay: see South America

Vietnam: see Singapore

Yugoslavia: Tel. +381 11 62 5344, Fax. +381 11 63 5777

Internet: <http://www.semiconductors.philips.com>

Contents

1	Description	1
2	Features	1
3	Applications	1
4	Quick reference data	1
5	Ordering information	2
5.1	Ordering options	2
6	Block diagram	3
7	Pinning information	3
7.1	Pinning	3
7.2	Pin description	4
8	Functional description	4
8.1	Power amplifier	4
8.2	Mode selection	5
9	Limiting values	5
10	Thermal characteristics	5
11	Static characteristics	5
12	Dynamic characteristics	6
13	Application information	7
14	Test information	7
14.1	Quality information	7
15	Package outline	8
16	Soldering	9
16.1	Introduction to soldering through-hole mount packages	9
16.2	Soldering by dipping or by solder wave ..	9
16.3	Manual soldering	9
16.4	Package related soldering information ...	9
17	Revision history	9
18	Data sheet status	10
19	Definitions	10
20	Disclaimers	10



PHILIPS

Let's make things better.