

## 16-CHANNEL CONSTANT-CURRENT LED SINK DRIVERS

### FEATURES

- 16 Constant-Current Output Channels
- Output Current Adjusted By External Resistor
- Constant Output Current Range: 5 mA to 120 mA
- Constant Output Current Invariant to Load Voltage Change
- Open-Load, Shorted-Load and Overtemperature Detection
- 256-Step Programmable Global Current Gain
- Excellent Output-Current Accuracy:
  - Between Channels: <  $\pm 6\%$  (Max), 10 mA to 50 mA
  - Between ICs: <  $\pm 6\%$  (Max), 10 mA to 50 mA
- 30-MHz Clock Frequency
- Schmitt-Trigger Input
- 3.3-V or 5-V Supply Voltage
- Thermal Shutdown for Overtemperature Protection
- ESD Performance: 2-kV HBM

### APPLICATIONS

- General LED Lighting Applications
- LED Display Systems
- LED Signage
- Automotive LED Lighting
- White Goods

### DESCRIPTION/ORDERING INFORMATION

The TLC5926/TLC5927 is designed for LED displays and LED lighting applications with open-load, shorted-load, and overtemperature detection, and constant-current control. The TLC5926/TLC5927 contains a 16-bit shift register and data latches, which convert serial input data into parallel output format. At the TLC5926/TLC5927 output stage, 16 regulated-current ports provide uniform and constant current for driving LEDs within a wide range of  $V_F$  (Forward Voltage) variations. Used in systems designed for LED display applications (e.g., LED panels), TLC5926/TLC5927 provides great flexibility and device performance. Users can adjust the output current from 5 mA to 120 mA through an external resistor,  $R_{ext}$ , which gives flexibility in controlling the light intensity of LEDs. TLC5926/TLC5927 is designed for up to 17 V at the output port. The high clock frequency, 30 MHz, also satisfies the system requirements of high-volume data transmission.

The TLC5926/TLC5927 provides a Special Mode in which two functions are included, Error Detection and Current Gain Control. In the TLC5926/TLC5927 there are two operation modes and three phases: Normal Mode phase, Mode Switching transition phase, and Special mode phase. The signal on the multiple-function pin  $\overline{OE}$ (ED2) is monitored, and when an one-clock-wide short pulse appears on  $\overline{OE}$ (ED2), TLC5926/TLC5927 enters the Mode Switching phase. At this time, the voltage level on LE(ED1) determines the next mode into which the TLC5926/TLC5927 switches.

In the Normal Mode phase, the serial data is transferred into TLC5926/TLC5927 via SDI, shifted in the shift register, and transferred out via SDO. LE(ED1) can latch the serial data in the shift register to the output latch.  $\overline{OE}$ (ED2) enables the output drivers to sink current.

In the Special Mode phase, the low-voltage-level signal  $\overline{OE}$ (ED2) can enable output channels and detect the status of the output current, to tell if the driving current level is enough or not. The detected error status is loaded into the 16-bit shift register and shifted out via SDO, along with the CLK signal. The system controller can read the error status to determine whether or not the LEDs are properly lit. In the Special Mode phase, TLC5926/TLC5927 also allows users to adjust the output current level by setting a runtime-programmable Configuration Code. The code is sent into TLC5926/TLC5927 via SDI. The positive pulse of LE(ED1) latches the code in the shift register into a built-in 8-bit configuration latch, instead of the output latch. The code affects the voltage at R-EXT and controls the output-current regulator. The output current can be adjusted finely by a gain ranging from 1/12 to 127/128 in 256 steps. Therefore, the current skew between ICs can be compensated within less than 1%, and this feature is suitable for white balancing in LED color-display panels.



Please be aware that an important notice concerning availability, standard warranty, and use in critical applications of Texas Instruments semiconductor products and disclaimers thereto appears at the end of this data sheet.

PowerPAD is a trademark of Texas Instruments.

**ORDERING INFORMATION<sup>(1)</sup>**

T <sub>A</sub>	PACKAGE <sup>(2)</sup>		ORDERABLE PART NUMBER	TOP-SIDE MARKING
-40°C to 85°C	PowerPAD™ – PWP	Reel of 2000	TLC5926IPWPR	Y5926
			TLC5927IPWPR	Y5927
	W-SOIC – DW	Reel of 2000	TLC5926IDWR	TLC5926I
			TLC5927IDWR	TLC5927I
	SSOP – DBQ	Reel of 2000	TLC5926IDBQR	TLC5926I
			TLC5927IDBQR	TLC5927I

- (1) For the most current package and ordering information, see the Package Option Addendum at the end of this document, or see the TI web site at [www.ti.com](http://www.ti.com).
- (2) Package drawings, thermal data, and symbolization are available at [www.ti.com/packaging](http://www.ti.com/packaging).

**BLOCK DIAGRAM**

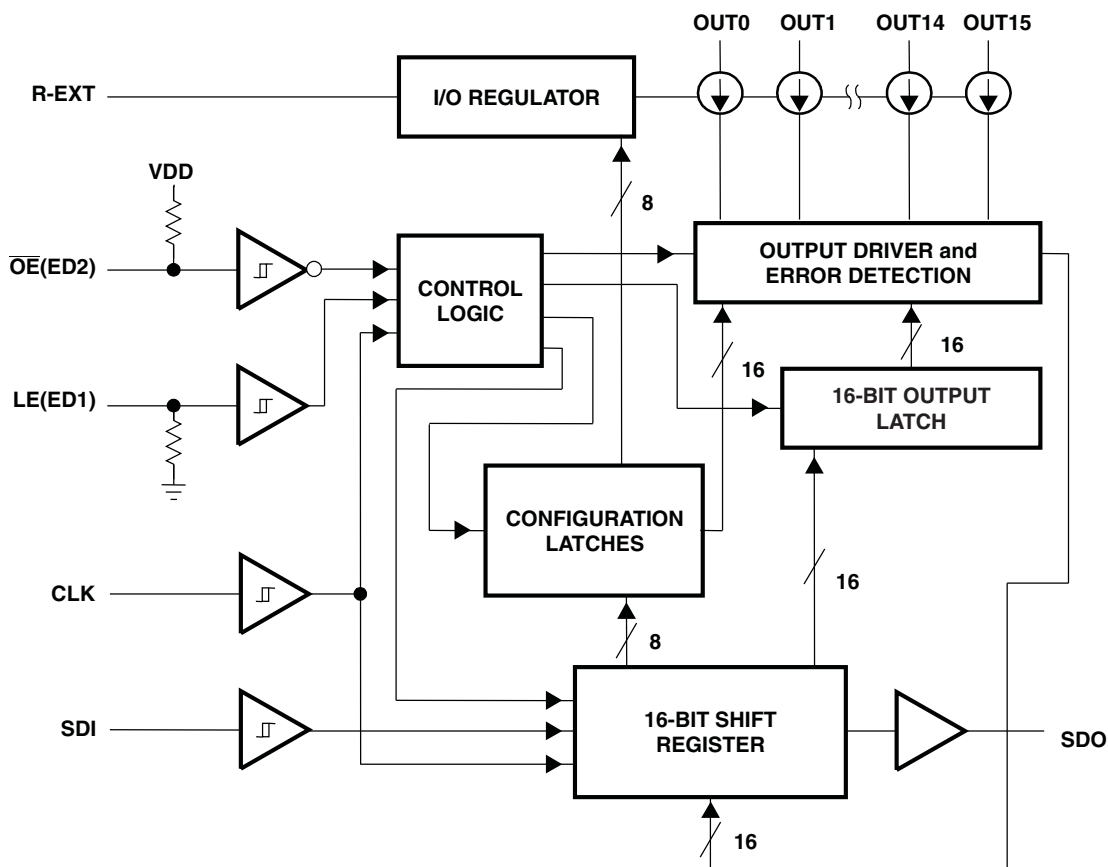

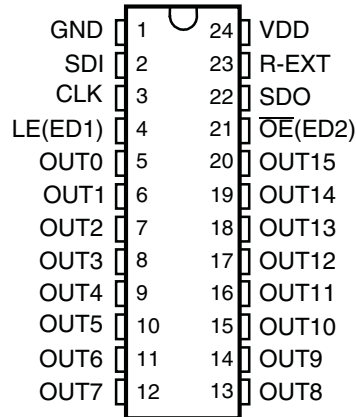
**DBQ, DW, OR PWP PACKAGE  
(TOP VIEW)**

**Pin Descriptions**

PIN NAME	DESCRIPTION
CLK	Clock input pin for data shift on rising edge
GND	Ground pin for control logic and current sink
LE(ED1)	Data strobe input pin Serial data is transferred to the respective latch when LE(ED1) is high. The data is latched when LE(ED1) goes low. Also, a control signal input for an Error Detection mode and Current Adjust mode (See Timing Diagram). LE(ED1) has an internal pulldown.
$\overline{OE}$ (ED2)	Output enable pin. When $\overline{OE}$ (ED2)(active) is low, the output drivers are enabled; when $\overline{OE}$ (ED2) is high, all output drivers are turned OFF (blanked). Also, a control signal input for an Error Detection mode and Current Adjust mode (See Timing Diagram). $\overline{OE}$ (ED2) has an internal pull-up.
OUT0–OUT15	Constant-current output pins
R-EXT	Input pin used to connect an external resistor for setting up all output currents
SDI	Serial-data input to the Shift register
SDO	Serial-data output to the following SDI of next driver IC or to the microcontroller
VDD	Supply voltage pin

**Diagnostic Features**

DEVICE <sup>(1)</sup>	OPEN-LOAD DETECTION	SHORT TO GND DETECTION	SHORT TO $V_{LED}$ DETECTION
TLC5926	x	x	
TLC5927	x	x	x

(1) The device has one single error register for all these conditions (one error bit per channel)

Timing Diagrams

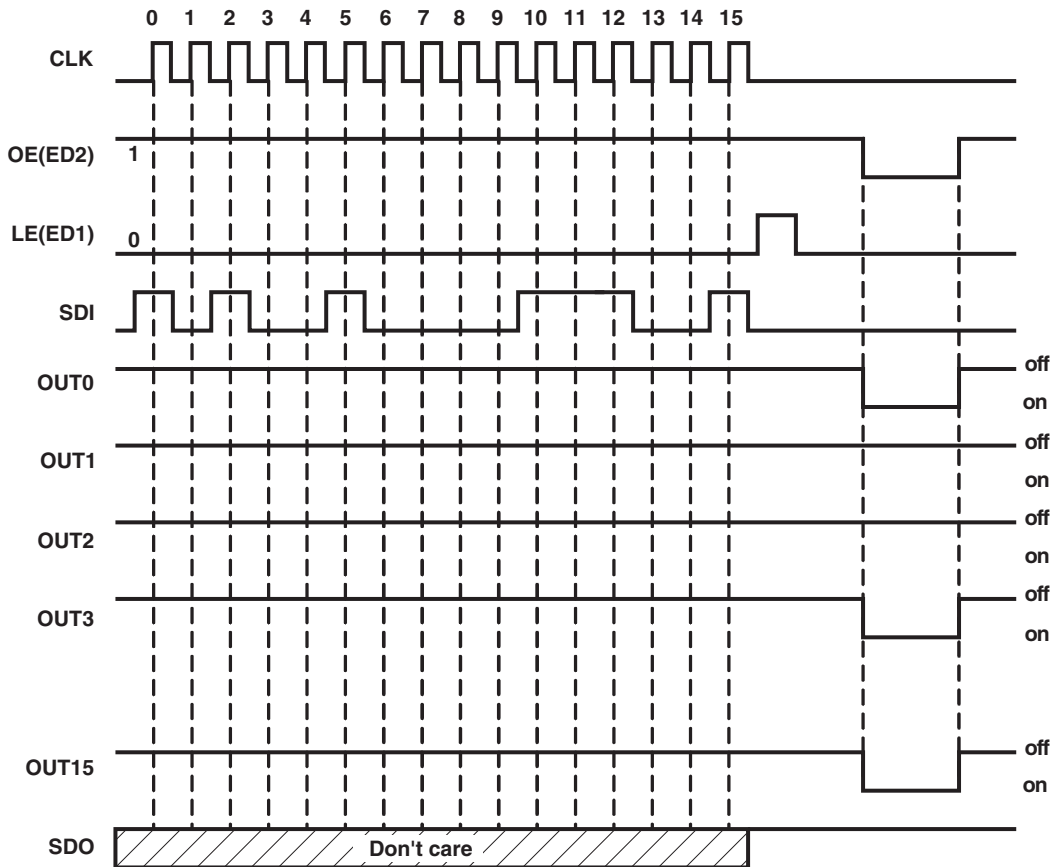

Figure 1. Normal Mode

Truth Table in Normal Mode

CLK	LE(ED1)	$\overline{OE}(ED2)$	SDI	OUT0...OUT15	SDO
↑	H	L	Dn	Dn...Dn - 7...Dn - 15	Dn - 15
↑	L	L	Dn + 1	No change	Dn - 14
↑	H	L	Dn + 2	Dn + 2...Dn - 5...Dn - 13	Dn - 13
↓	X	L	Dn + 3	Dn + 2...Dn - 5...Dn - 13	Dn - 13
↓	X	H	Dn + 3	off	Dn - 13

The signal sequence shown in Figure 2 makes the TLC5926/TLC5927 enter Current Adjust and Error Detection mode.

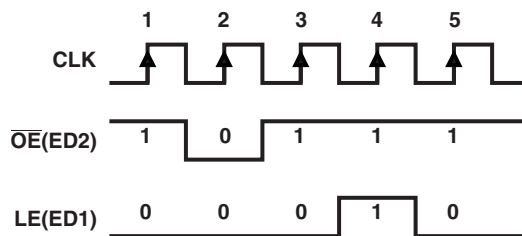

Figure 2. Switching to Special Mode

In the Current Adjust mode, sending the positive pulse of LE(ED1), the content of the shift register (a current adjust code) is written to the 16-bit configuration latch (see Figure 3).

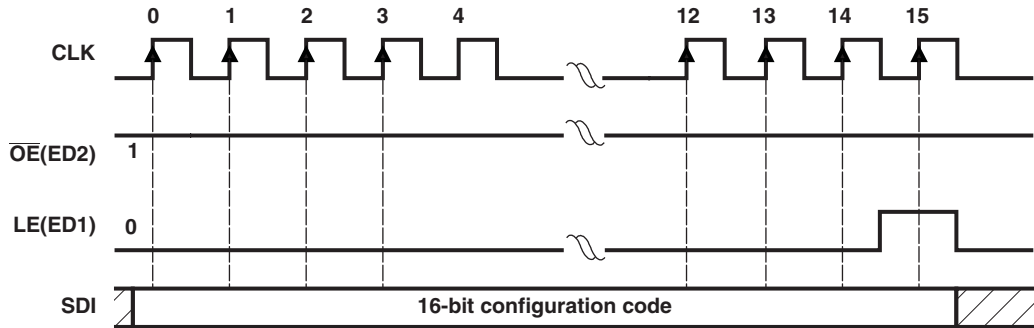

Figure 3. Writing Configuration Code

When the TLC5926/TLC5927 is in the error detection mode, the signal sequence shown in Figure 4 enables a system controller to read error status codes through SDO.

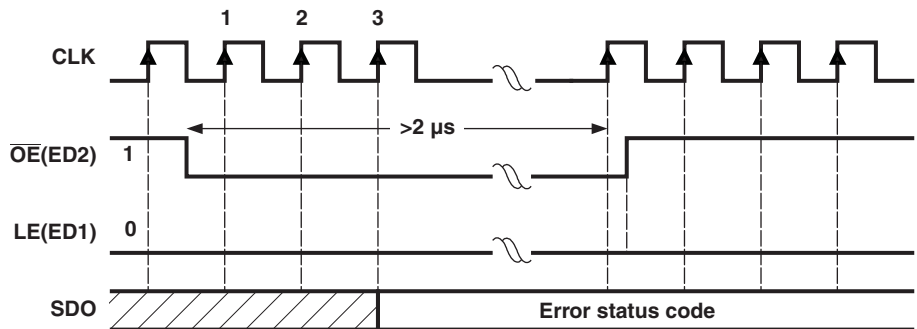

Figure 4. Reading Error Status Code

The signal sequence shown in Figure 5 makes TLC5926/TLC5927 resume the Normal mode. Switching to Normal mode resets all internal Error Status registers. OE (ED2) always enables the output port, whether the TLC5926/TLC5927 enters current adjust mode or not.

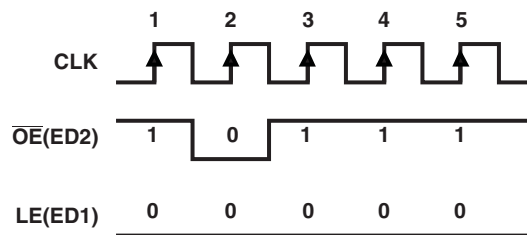

Figure 5. Switching to Normal Mode

## Absolute Maximum Ratings

over operating free-air temperature range (unless otherwise noted)

		MIN	MAX	UNIT
$V_{DD}$	Supply voltage	0	7	V
$V_I$	Input voltage	-0.4	$V_{DD} + 0.4$	V
$V_O$	Output voltage	-0.5	20	V
$I_{OUT}$	Output current		120	mA
$I_{GND}$	GND terminal current		1920	mA
$T_A$	Free-air operating temperature range	-40	85	°C
$T_J$	Operating junction temperature range	-40	150	°C
$T_{stg}$	Storage temperature range	-55	150	°C
ESD	Electrostatic-Discharge Capability $V_{(HBMESD)}$ (100 pF, 1.5 k $\Omega$ )		2	kV

## Power Dissipation and Thermal Impedance

			MIN	MAX	UNIT
$P_D$	Power dissipation	Mounted on JEDEC 4-layer board (JESD 51-7), No airflow, $T_A = 25^\circ\text{C}$ , $T_J = 125^\circ\text{C}$	DBQ package	1.6	W
			DW package	2.2	
			PWP package	2.3	
		Mounted on JEDEC 4-layer board (JESD 51-5), No airflow, $T_A = 25^\circ\text{C}$ , $T_J = 125^\circ\text{C}$	PWP package	2.9	
$\theta_{JA}$	Thermal impedance, junction to free air	Mounted on JEDEC 1-layer board (JESD 51-3), No airflow	DBQ package	99.8	°C/W
			DW package	80.5	
			PWP package	63.9	
		Mounted on JEDEC 4-layer board (JESD 51-7), No airflow	DBQ package	61.0	
			DW package	45.5	
			PWP package	42.7	
		Mounted on JEDEC 4-layer board (JESD 51-5), No airflow	PWP package	34.5	
$\theta_{JP}$	Thermal impedance, junction to pad	PWP package	2.0	°C/W	

## Recommended Operating Conditions

over operating free-air temperature range (unless otherwise noted)

		TEST CONDITIONS		MIN	MAX	UNIT
$V_{DD}$	Supply voltage			3	5.5	V
$V_O$	Supply voltage to the output pins	OUT0–OUT15			17	V
$I_O$	Output current	DC test circuit	$V_O \geq 0.6\text{ V}$	5	120	mA
			$V_O \geq 1\text{ V}$			
$I_{OH}$	High-level output current	SDO			-1	mA
$I_{OL}$	Low-level output current	SDO			1	mA
$V_{IH}$	High-level input voltage	CLK, $\overline{OE}$ (ED2), LE(ED1), and SDI		$0.7 \times V_{DD}$	$V_{DD}$	V
$V_{IL}$	Low-level input voltage	CLK, $\overline{OE}$ (ED2), LE(ED1), and SDI		0	$0.3 \times V_{DD}$	V

## Recommended Timing

 $V_{DD} = 3\text{ V to }5.5\text{ V}$  (unless otherwise noted)

		TEST CONDITIONS	MIN	MAX	UNIT
$t_{w(L)}$	LE(ED1) pulse duration	Normal mode	20		ns
$t_{w(CLK)}$	CLK pulse duration	Normal mode	20		ns
$t_{w(OE)}$	$\overline{OE}$ (ED2) pulse duration	Normal mode	1000		ns
$t_{su(D)}$	Setup time for SDI	Normal mode	7		ns
$t_{h(D)}$	Hold time for SDI	Normal mode	3		ns
$t_{su(L)}$	Setup time for LE(ED1)	Normal mode	18		ns
$t_{h(L)}$	Hold time for LE(ED1)	Normal mode	18		ns
$t_{w(CLK)}$	CLK pulse duration	Error Detection mode	20		ns
$t_{w(ED2)}$	$\overline{OE}$ (ED2) pulse duration	Error Detection mode	2000		ns
$t_{su(ED1)}$	Setup time for LE(ED1)	Error Detection mode	7		ns
$t_{h(ED1)}$	Hold time for LE(ED1)	Error Detection mode	10		ns
$t_{su(ED2)}$	Setup time for $\overline{OE}$ (ED2)	Error Detection mode	7		ns
$t_{h(ED2)}$	Hold time for $\overline{OE}$ (ED2)	Error Detection mode	10		ns
$f_{CLK}$	Clock frequency	Cascade operation, $V_{DD} = 3\text{ V to }5.5\text{ V}$		30	MHz

**Electrical Characteristics**

$V_{DD} = 3\text{ V}$ ,  $T_J = -40^\circ\text{C}$  to  $125^\circ\text{C}$  (unless otherwise noted)

PARAMETER		TEST CONDITIONS	MIN	TYP	MAX	UNIT	
$V_O$	Supply voltage to the output pins				17	V	
$I_O$	Output current	$V_O \geq 0.6\text{ V}$	5			mA	
		$V_O \geq 1\text{ V}$			120		
$V_{IH}$	High-level input voltage		$0.7 \times V_{DD}$		$V_{DD}$	V	
$V_{IL}$	Low-level input voltage		GND		$0.3 \times V_{DD}$		
$I_{leak}$	Output leakage current	$V_{OH} = 17\text{ V}$	$T_J = 25^\circ\text{C}$		0.5	$\mu\text{A}$	
			$T_J = 125^\circ\text{C}$		1		
$V_{OH}$	High-level output voltage	SDO, $I_{OL} = -1\text{ mA}$	$V_{DD} - 0.4$			V	
$V_{OL}$	Low-level output voltage	SDO, $I_{OH} = 1\text{ mA}$			0.4	V	
$I_{O(1)}$	Output current 1	$V_{OUT} = 0.6\text{ V}$ , $R_{ext} = 720\ \Omega$ , CG = 0.992		26		mA	
	Output current error, die-die	$I_{OL} = 26\text{ mA}$ , $V_O = 0.6\text{ V}$ , $R_{ext} = 720\ \Omega$ , $T_J = 25^\circ\text{C}$			$\pm 6$		%
	Output current error, channel-to-channel	$I_{OL} = 26\text{ mA}$ , $V_O = 0.6\text{ V}$ , $R_{ext} = 720\ \Omega$ , $T_J = 25^\circ\text{C}$			$\pm 6$		
$I_{O(2)}$	Output current 2	$V_O = 0.8\text{ V}$ , $R_{ext} = 360\ \Omega$ , CG = 0.992		52		mA	
	Output current error, die-die	$I_{OL} = 52\text{ mA}$ , $V_O = 0.8\text{ V}$ , $R_{ext} = 360\ \Omega$ , $T_J = 25^\circ\text{C}$			$\pm 6$		%
	Output current error, channel-to-channel	$I_{OL} = 52\text{ mA}$ , $V_O = 0.8\text{ V}$ , $R_{ext} = 360\ \Omega$ , $T_J = 25^\circ\text{C}$			$\pm 6$		
$I_{OUT\text{ vs }V_{OUT}}$	Output current vs output voltage regulation	$V_O = 1\text{ V}$ to $3\text{ V}$ , $I_O = 26\text{ mA}$		$\pm 0.1$		%V	
$I_{OUT\text{ vs }V_{DD}}$	Output current vs supply voltage	$V_{DD} = 3.0\text{ V}$ to $5.5\text{ V}$ , $I_O = 26\text{ mA}/120\text{ mA}$		$\pm 1$			
	Pullup resistance	$\overline{OE}(ED2)$	250	500	800	k $\Omega$	
	Pulldown resistance	LE(ED1)	250	500	800	k $\Omega$	
$T_{sd}$	Overtemperature shutdown <sup>(1)</sup>		150	175	200	$^\circ\text{C}$	
$T_{hys}$	Restart temperature hysteresis			15		$^\circ\text{C}$	
$I_{OUT,Th}$	Threshold current for open error detection	$I_{OUT,target} = 5\text{ mA}$ to $120\text{ mA}$		$0.5 \times I_{target}$		%	
$V_{OUT,TTh}$	Trigger threshold voltage for short-error detection (TLC5927 only)	$I_{OUT,target} = 5\text{ mA}$ to $120\text{ mA}$	2.4	2.6	3.1	V	
$V_{OUT,RTh}$	Return threshold voltage for short-error detection (TLC5927 only)	$I_{OUT,target} = 5\text{ mA}$ to $120\text{ mA}$	2.2			V	
$I_{DD}$	Supply current	OUT0–OUT15 = off, $R_{ext} = \text{Open}$ , $\overline{OE} = V_{IH}$			10	mA	
		OUT0–OUT15 = off, $R_{ext} = 720\ \Omega$ , $\overline{OE} = V_{IH}$			14		
		OUT0–OUT15 = off, $R_{ext} = 360\ \Omega$ , $\overline{OE} = V_{IH}$			18		
		OUT0–OUT15 = off, $R_{ext} = 180\ \Omega$ , $\overline{OE} = V_{IH}$			20		
		OUT0–OUT15 = on, $R_{ext} = 720\ \Omega$ , $\overline{OE} = V_{IL}$			14		
		OUT0–OUT15 = on, $R_{ext} = 360\ \Omega$ , $\overline{OE} = V_{IL}$			18		
		OUT0–OUT15 = on, $R_{ext} = 180\ \Omega$ , $\overline{OE} = V_{IL}$			20		

(1) Specified by design



## Electrical Characteristics

 $V_{DD} = 5.5\text{ V}$ ,  $T_J = -40^\circ\text{C}$  to  $125^\circ\text{C}$  (unless otherwise noted)

PARAMETER		TEST CONDITIONS	MIN	TYP	MAX	UNIT	
$V_O$	Supply voltage to the output pins				17	V	
$I_O$	Output current	$V_O \geq 0.6\text{ V}$	5			mA	
		$V_O \geq 1\text{ V}$			120		
$V_{IH}$	High-level input voltage		$0.7 \times V_{DD}$		$V_{DD}$	V	
$V_{IL}$	Low-level input voltage		GND		$03 \times V_{DD}$		
$I_{leak}$	Output leakage current	$V_{OH} = 17\text{ V}$	$T_J = 25^\circ\text{C}$		0.5	$\mu\text{A}$	
			$T_J = 125^\circ\text{C}$		1		
$V_{OH}$	High-level output voltage	SDO, $I_{OL} = -1\text{ mA}$	$V_{DD} - 0.4$			V	
$V_{OL}$	Low-level output voltage	SDO, $I_{OH} = 1\text{ mA}$			0.4	V	
$I_{O(1)}$	Output current 1	$V_{OUT} = 0.6\text{ V}$ , $R_{ext} = 720\ \Omega$ , CG = 0.992		26		mA	
	Output current error, die-die	$I_{OL} = 26\text{ mA}$ , $V_O = 0.6\text{ V}$ , $R_{ext} = 720\ \Omega$ , $T_J = 25^\circ\text{C}$			$\pm 6$		%
	Output current error, channel-to-channel	$I_{OL} = 26\text{ mA}$ , $V_O = 0.6\text{ V}$ , $R_{ext} = 720\ \Omega$ , $T_J = 25^\circ\text{C}$			$\pm 6$		
$I_{O(2)}$	Output current 2	$V_O = 0.8\text{ V}$ , $R_{ext} = 360\ \Omega$ , CG = 0.992		52		mA	
	Output current error, die-die	$I_{OL} = 52\text{ mA}$ , $V_O = 0.8\text{ V}$ , $R_{ext} = 360\ \Omega$ , $T_J = 25^\circ\text{C}$			$\pm 6$		%
	Output current error, channel-to-channel	$I_{OL} = 52\text{ mA}$ , $V_O = 0.8\text{ V}$ , $R_{ext} = 360\ \Omega$ , $T_J = 25^\circ\text{C}$			$\pm 6$		
$I_{OUT\text{ vs }V_{OUT}}$	Output current vs output voltage regulation	$V_O = 1\text{ V}$ to $3\text{ V}$ , $I_O = 26\text{ mA}$		$\pm 0.1$		%V	
$I_{OUT\text{ vs }V_{DD}}$	Output current vs supply voltage	$V_{DD} = 3.0\text{ V}$ to $5.5\text{ V}$ , $I_O = 26\text{ mA}/120\text{ mA}$		$\pm 1$			
	Pullup resistance	$\overline{OE}(ED2)$ ,	250	500	800	k $\Omega$	
	Pulldown resistance	LE(ED1),	250	500	800	k $\Omega$	
$T_{sd}$	Overtemperature shutdown <sup>(1)</sup>		150	175	200	$^\circ\text{C}$	
$T_{hys}$	Restart temperature hysteresis			15		$^\circ\text{C}$	
$I_{OUT,Th}$	Threshold current for open error detection	$I_{OUT,target} = 5\text{ mA}$ to $120\text{ mA}$		$0.5 \times I_{target}$		%	
$V_{OUT,TTh}$	Trigger threshold voltage for short-error detection (TLC5927 only)	$I_{OUT,target} = 5\text{ mA}$ to $120\text{ mA}$	2.4	2.6	3.1	V	
$V_{OUT,RTh}$	Return threshold voltage for short-error detection (TLC5927 only)	$I_{OUT,target} = 5\text{ mA}$ to $120\text{ mA}$	2.2			V	
$I_{DD}$	Supply current	OUT0–OUT15 = off, $R_{ext} = \text{Open}$ , $\overline{OE} = V_{IH}$			11	mA	
		OUT0–OUT15 = off, $R_{ext} = 720\ \Omega$ , $\overline{OE} = V_{IH}$			17		
		OUT0–OUT15 = off, $R_{ext} = 360\ \Omega$ , $\overline{OE} = V_{IH}$			18		
		OUT0–OUT15 = off, $R_{ext} = 180\ \Omega$ , $\overline{OE} = V_{IH}$			25		
		OUT0–OUT15 = on, $R_{ext} = 720\ \Omega$ , $\overline{OE} = V_{IL}$			17		
		OUT0–OUT15 = on, $R_{ext} = 360\ \Omega$ , $\overline{OE} = V_{IL}$			18		
		OUT0–OUT15 = on, $R_{ext} = 180\ \Omega$ , $\overline{OE} = V_{IL}$			25		

(1) Specified by design

## Switching Characteristics

$V_{DD} = 3\text{ V}$ ,  $T_J = -40^\circ\text{C}$  to  $125^\circ\text{C}$  (unless otherwise noted)

PARAMETER		TEST CONDITIONS	MIN	TYP	MAX	UNIT
$t_{PLH1}$	Low-to-high propagation delay time, CLK to OUTn	$V_{IH} = V_{DD}$ , $V_{IL} = \text{GND}$ , $R_{ext} = 360\ \Omega$ , $V_L = 4\text{ V}$ , $R_L = 44\ \Omega$ , $C_L = 70\text{ pF}$ , $CG = 0.992$	35	65	105	ns
$t_{PLH2}$	Low-to-high propagation delay time, LE(ED1) to OUTn		35	65	105	ns
$t_{PLH3}$	Low-to-high propagation delay time, $\overline{OE}$ (ED2) to OUTn		35	65	105	ns
$t_{PLH4}$	Low-to-high propagation delay time, CLK to SDO			20	45	ns
$t_{PHL1}$	High-to-low propagation delay time, CLK to OUTn		200	300	470	ns
$t_{PHL2}$	High-to-low propagation delay time, LE(ED1) to OUTn		200	300	470	ns
$t_{PHL3}$	High-to-low propagation delay time, $\overline{OE}$ (ED2) to OUTn		200	300	470	ns
$t_{PHL4}$	High-to-low propagation delay time, CLK to SDO			20	40	ns
$t_{w(\text{CLK})}$	Pulse duration, CLK		20			ns
$t_{w(L)}$	Pulse duration LE(ED1)		20			ns
$t_{w(\text{OE})}$	Pulse duration, $\overline{OE}$ (ED2)		1000			ns
$t_{w(\text{ED2})}$	Pulse duration, $\overline{OE}$ (ED2) in Error Detection mode		2			$\mu\text{s}$
$t_{h(\text{ED1,ED2})}$	Hold time, LE(ED1), and $\overline{OE}$ (ED2)		10			ns
$t_{h(D)}$	Hold time, SDI		5			ns
$t_{su(D,ED1,ED2)}$	Setup time, SDI, LE(ED1), and $\overline{OE}$ (ED2)		7			ns
$t_{h(L)}$	Hold time, LE(ED1), Normal mode		18			ns
$t_{su(L)}$	Setup time, LE(ED1), Normal mode		18			ns
$t_r$	Rise time, CLK <sup>(1)</sup>				500	ns
$t_f$	Fall time, CLK <sup>(1)</sup>				500	ns
$t_{or}$	Rise time, outputs (off)				245	ns
$t_{of}$	Rise time, outputs (on)			600	ns	
$f_{\text{CLK}}$	Clock frequency	Cascade operation			30	MHz

(1) If the devices are connected in cascade and  $t_r$  or  $t_f$  is large, it may be critical to achieve the timing required for data transfer between two cascaded devices.

## Switching Characteristics

 $V_{DD} = 5.5\text{ V}$ ,  $T_J = -40^\circ\text{C}$  to  $125^\circ\text{C}$  (unless otherwise noted)

PARAMETER		TEST CONDITIONS	MIN	TYP	MAX	UNIT
$t_{PLH1}$	Low-to-high propagation delay time, CLK to OUTn	$V_{IH} = V_{DD}$ , $V_{IL} = \text{GND}$ , $R_{ext} = 360\ \Omega$ , $V_L = 4\text{ V}$ , $R_L = 44\ \Omega$ , $C_L = 70\text{ pF}$ , $CG = 0.992$	27	65	95	ns
$t_{PLH2}$	Low-to-high propagation delay time, LE(ED1) to OUTn		27	65	95	ns
$t_{PLH3}$	Low-to-high propagation delay time, $\overline{OE}(ED2)$ to OUTn		27	65	95	ns
$t_{PLH4}$	Low-to-high propagation delay time, CLK to SDO			20	30	ns
$t_{PHL1}$	High-to-low propagation delay time, CLK to OUTn		180	300	445	ns
$t_{PHL2}$	High-to-low propagation delay time, LE(ED1) to OUTn		180	300	445	ns
$t_{PHL3}$	High-to-low propagation delay time, $\overline{OE}(ED2)$ to OUTn		180	300	445	ns
$t_{PHL4}$	High-to-low propagation delay time, CLK to SDO			20	30	ns
$t_{w(\text{CLK})}$	Pulse duration, CLK		20			ns
$t_{w(L)}$	Pulse duration LE(ED1)		20			ns
$t_{w(\text{OE})}$	Pulse duration, $\overline{OE}(ED2)$		1000			ns
$t_{w(\text{ED2})}$	Pulse duration, $\overline{OE}(ED2)$ in Error Detection mode		2			$\mu\text{s}$
$t_{h(\text{ED1,ED2})}$	Hold time, LE(ED1), and $\overline{OE}(ED2)$		10			ns
$t_{h(D)}$	Hold time, SDI		3			ns
$t_{su(D,ED1,ED2)}$	Setup time, SDI, LE(ED1), and $\overline{OE}(ED2)$		4			ns
$t_{h(L)}$	Hold time, LE(ED1), Normal mode		15			ns
$t_{su(L)}$	Setup time, LE(ED1), Normal mode		15			ns
$t_r$	Rise time, CLK <sup>(1)</sup>				500	ns
$t_f$	Fall time, CLK <sup>(1)</sup>				500	ns
$t_{or}$	Rise time, outputs (off)				245	ns
$t_{of}$	Rise time, outputs (on)			570	ns	
$f_{\text{CLK}}$	Clock frequency	Cascade operation			30	MHz

(1) If the devices are connected in cascade and  $t_r$  or  $t_f$  is large, it may be critical to achieve the timing required for data transfer between two cascaded devices.

PARAMETER MEASUREMENT INFORMATION

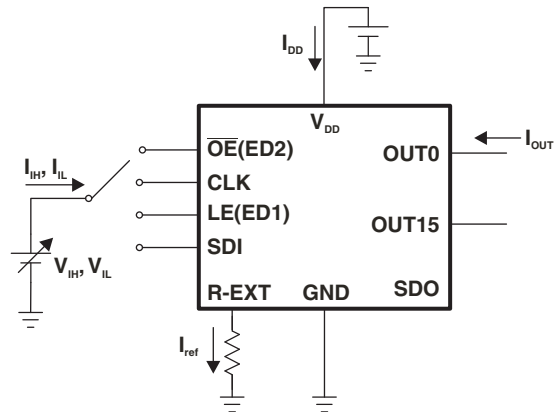

Figure 6. Test Circuit for Electrical Characteristics

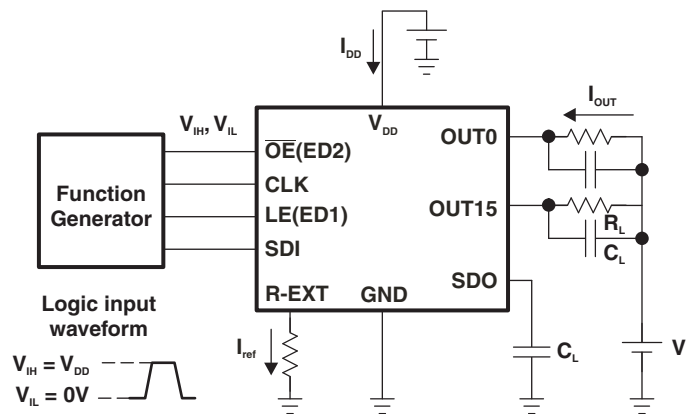

Figure 7. Test Circuit for Switching Characteristics

PARAMETER MEASUREMENT INFORMATION (continued)

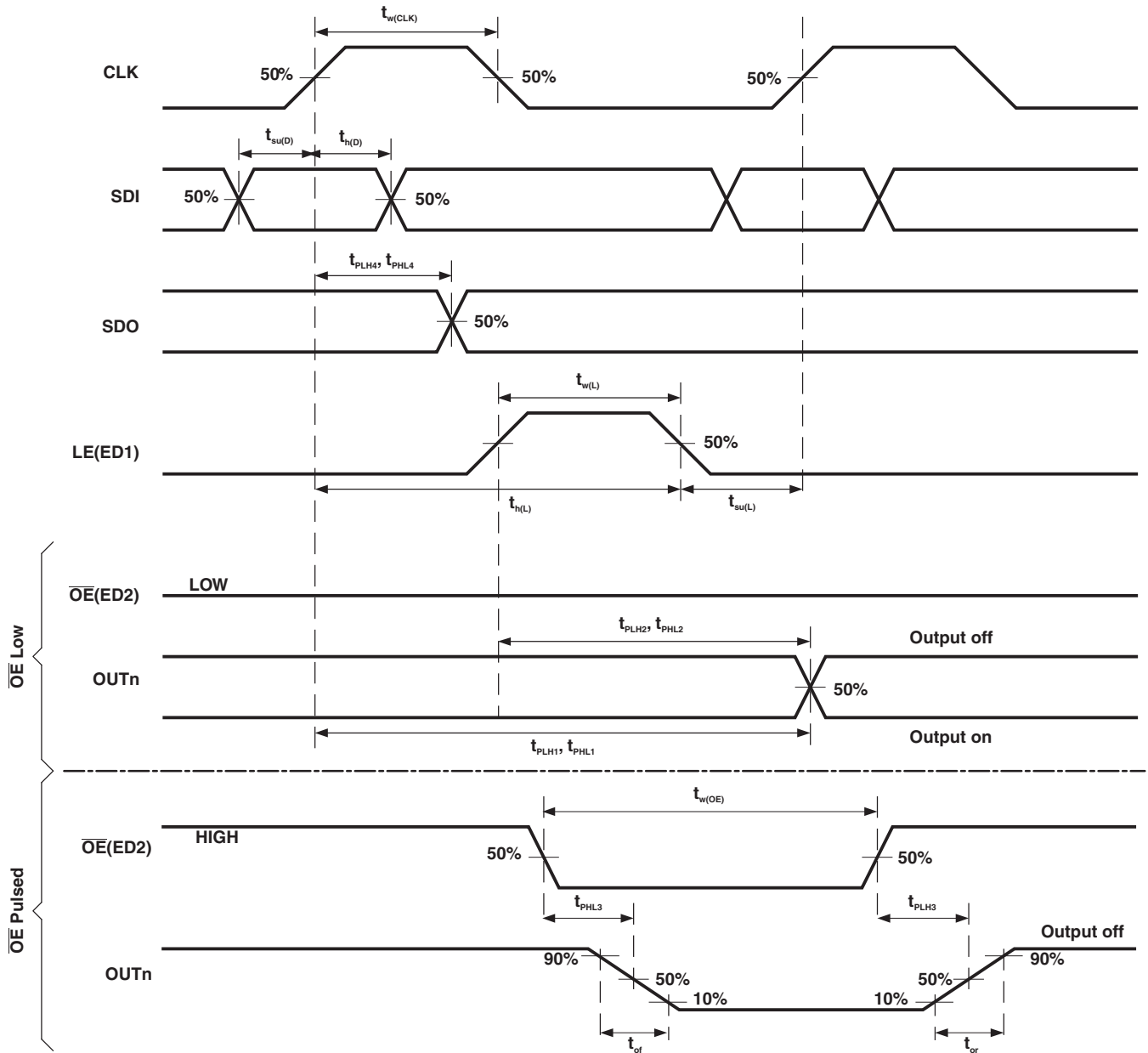

Figure 8. Normal Mode Timing Waveforms

PARAMETER MEASUREMENT INFORMATION (continued)

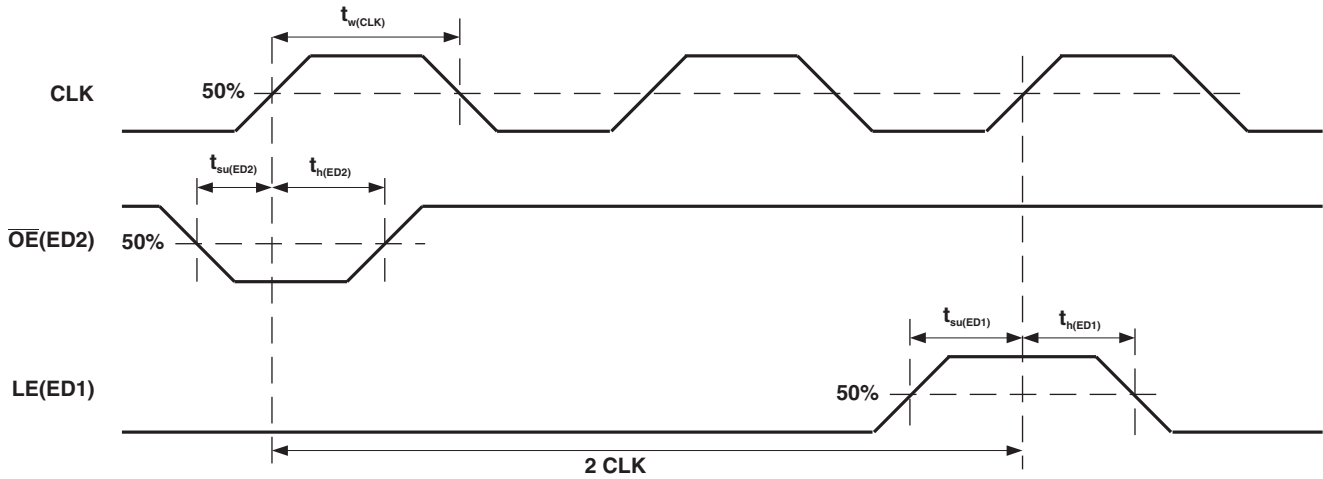

Figure 9. Switching to Special Mode Timing Waveforms

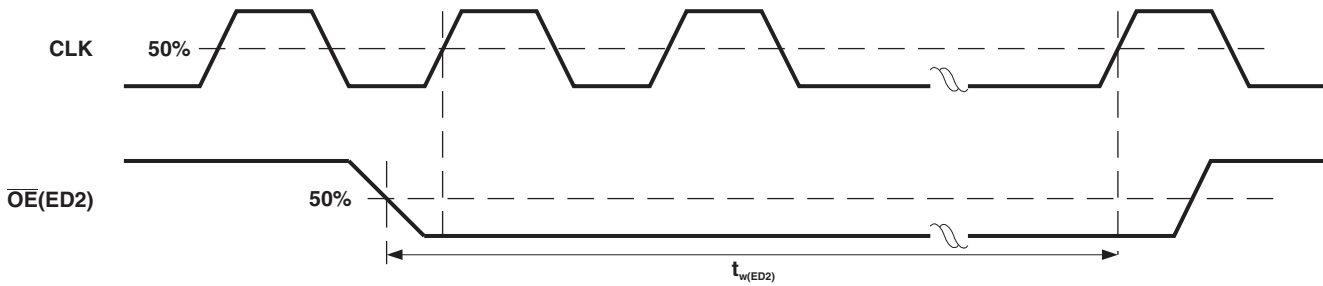

Figure 10. Reading Error Status Code Timing Waveforms

## APPLICATION INFORMATION

### Operating Principles

#### Constant Current

In LED display applications, TLC5926/TLC5927 provides nearly no current variations from channel to channel and from IC to IC. While  $I_{OUT} \leq 50$  mA, the maximum current skew between channels is less than  $\pm 6\%$  and between ICs is less than  $\pm 6\%$ .

#### Adjusting Output Current

TLC5926/TLC5927 scales up the reference current,  $I_{ref}$ , set by the external resistor  $R_{ext}$  to sink a current,  $I_{out}$ , at each output port. Users can follow the below formulas to calculate the target output current  $I_{OUT,target}$  in the saturation region:

$$V_{R-EXT} = 1.26 \text{ V} \times VG$$

$I_{ref} = V_{R-EXT}/R_{ext}$ , if another end of the external resistor  $R_{ext}$  is connected to ground.

$$I_{OUT,target} = I_{ref} \times 15 \times 3^{CM - 1}$$

Where  $R_{ext}$  is the resistance of the external resistor connected to the R-EXT terminal, and  $V_{R-EXT}$  is the voltage of R-EXT, which is controlled by the programmable voltage gain (VG), which is defined by the Configuration Code. The Current Multiplier (CM) determines that the ratio  $I_{OUT,target}/I_{ref}$  is 15 or 5. After power on, the default value of VG is  $127/128 = 0.992$ , and the default value of CM is 1, so that the ratio  $I_{OUT,target}/I_{ref} = 15$ . Based on the default VG and CM.

$$V_{R-EXT} = 1.26 \text{ V} \times 127/128 = 1.25 \text{ V}$$

$$I_{OUT,target} = (1.25 \text{ V}/R_{ext}) \times 15$$

Therefore, the default current is approximately 52 mA at 360  $\Omega$  and 26 mA at 720  $\Omega$ . The default relationship after power on between  $I_{OUT,target}$  and  $R_{ext}$  is shown in Figure 11.

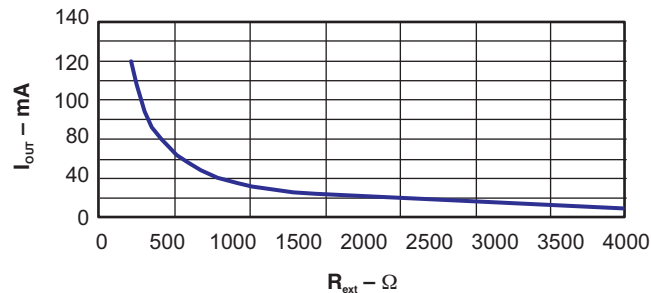

Figure 11. Default Relationship Curve Between  $I_{OUT,target}$  and  $R_{ext}$

## Operation Phases

### Operation Mode Switching

In order to switch between its two modes, TLC5926/TLC5927 monitors the signal  $\overline{OE}(ED2)$ . When a one-clock-wide pulse of  $\overline{OE}(ED2)$  appears, TLC5926/TLC5927 enters the two-clock-period transition phase, the Mode Switching phase. After power on, the default operation mode is the Normal Mode (see Figure 12).

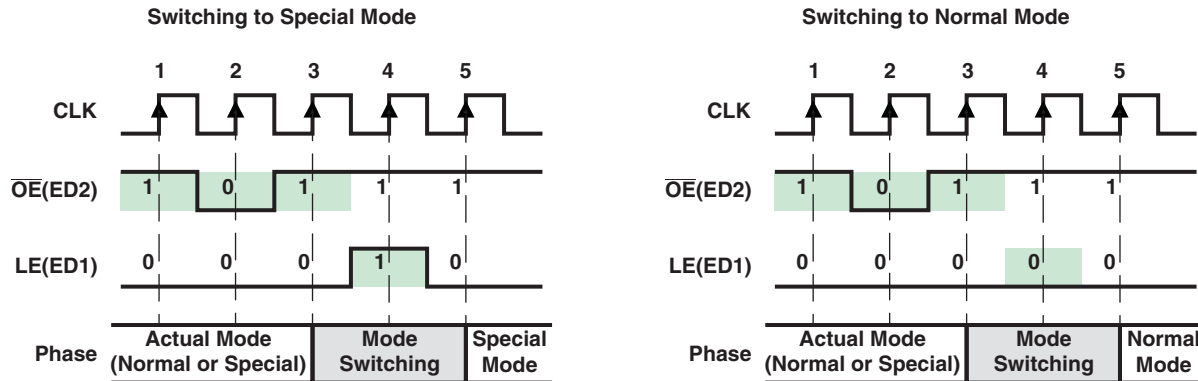

Figure 12. Mode Switching

As shown in Figure 12, once a one-clock-wide short pulse (101) of  $\overline{OE}(ED2)$  appears, TLC5926/TLC5927 enters the Mode Switching phase. At the fourth rising edge of CLK, if LE(ED1) is sampled as voltage high, TLC5926/TLC5927 switches to Special mode; otherwise, it switches to Normal mode. The signal LE(ED1) between the third and the fifth rising edges of CLK cannot latch any data. Its level is used only to determine into which mode to switch. However, the short pulse of  $\overline{OE}(ED2)$  can still enable the output ports. During mode switching, the serial data can still be transferred through SDI and shifted out from SDO.

#### NOTES:

1. The signal sequence for the mode switching may be used frequently to ensure that the TLC5926/TLC5927 is in the proper mode.
2. The 1 and 0 on the LE(ED1) signal are sampled at the rising edge of CLK. The X means its level does not affect the result of mode switching mechanism.
3. After power on, the default operation mode is Normal mode.

### Normal Mode Phase

Serial data is transferred into TLC5926/TLC5927 via SDI, shifted in the Shift Register, and output via SDO. LE(ED1) can latch the serial data in the Shift Register to the Output Latch.  $\overline{OE}(ED2)$  enables the output drivers to sink current. These functions differ only as described in Operation Mode Switching, in which case, a short pulse triggers TLC5926/TLC5927 to switch the operation mode. However, as long as LE(ED1) is high in the Mode Switching phase, TLC5926/TLC5927 remains in the Normal mode, as if no mode switching occurred.

### Special Mode Phase

In the Special mode, as long as  $\overline{OE}(ED2)$  is not low, the serial data is shifted to the Shift Register via SDI and shifted out via SDO, as in the Normal mode. However, there are two differences between the Special Mode and the Normal Mode, as shown in the following sections.



### Reading Error Status Code in Special Mode

When  $\overline{OE}(ED2)$  is pulled low while in Special mode, error detection and load error status codes are loaded into the Shift Register, in addition to enabling output ports to sink current. Figure 13 shows the timing sequence for error detection. The 0 and 1 signal levels are sampled at the rising edge of each CLK. At least three zeros must be sampled at the voltage low signal  $\overline{OE}(ED2)$ . Immediately after the second 0 is sampled, the data input source of the Shift Register changes to the 16-bit parallel Error Status Code register, instead of from the serial data on SDI. Normally, the error status codes are generated at least 2  $\mu$ s after the falling edge of  $\overline{OE}(ED2)$ . The occurrence of the third or later 0 saves the detected error status codes into the Shift Register. Therefore, when  $\overline{OE}(ED2)$  is low, the serial data cannot be shifted into TLC5926/TLC5927 via SDI. When  $\overline{OE}(ED2)$  is pulled high, the data input source of the Shift Register is changed back to SDI. At the same time, the output ports are disabled and the error detection is completed. Then, the error status codes saved in the Shift Register can be shifted out via SDO bit-by-bit along with CLK, as well as the new serial data can be shifted into TLC5926/TLC5927 via SDI.

While in Special mode, the TLC5926/TLC5927 cannot simultaneously transfer serial data and detect LED load error status.

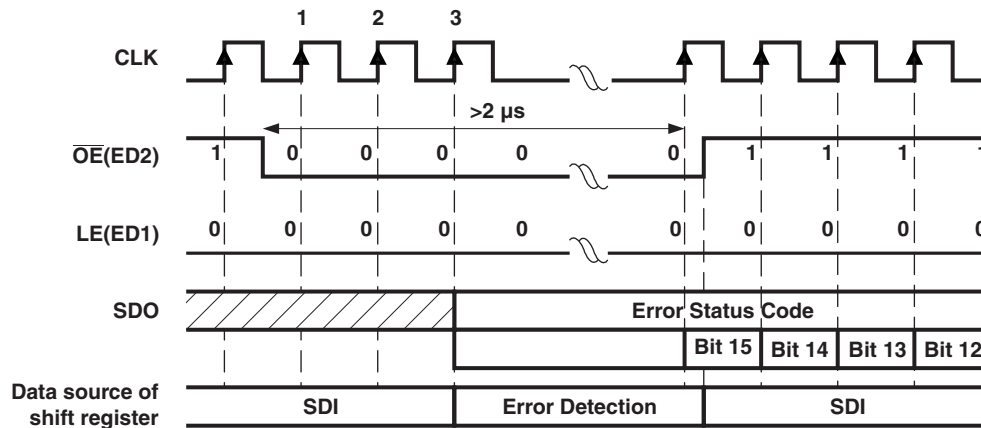

Figure 13. Reading Error Status Code

### Writing Configuration Code in Special Mode

When in Special mode, the active high signal LE(ED1) latches the serial data in the Shift Register to the Configuration Latch, instead of the Output Latch. The latched serial data is used as the Configuration Code.

The code is stored until power off or the Configuration Latch is rewritten. As shown in Figure 14, the timing for writing the Configuration Code is the same as the timing in the Normal Mode to latching output channel data. Both the Configuration Code and Error Status Code are transferred in the common 16-bit Shift Register. Users must pay attention to the sequence of error detection and current adjustment to avoid the Configuration Code being overwritten by Error Status Code.

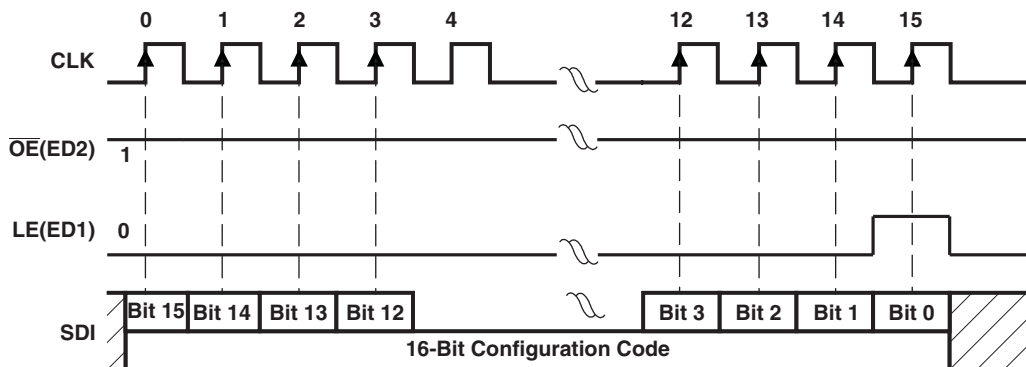

Figure 14. Writing Configuration Code

## Open-Circuit Detection Principle

The LED Open-Circuit Detection compares the effective current level  $I_{OUT}$  with the open load detection threshold current  $I_{OUT,Th}$ . If  $I_{OUT}$  is below the  $I_{OUT,Th}$  threshold, the TLC5926/TLC5927 detects an open-load condition. This error status can be read as an error status code in the Special mode. For open-circuit error detection, a channel must be on.

**Table 1. Open-Circuit Detection**

STATE OF OUTPUT PORT	CONDITION OF OUTPUT CURRENT	ERROR STATUS CODE	MEANING
Off	$I_{OUT} = 0 \text{ mA}$	0	Detection not possible
On	$I_{OUT} < I_{OUT,Th}^{(1)}$	0	Open circuit
	$I_{OUT} \geq I_{OUT,Th}^{(1)}$	Channel n error status bit 1	Normal

(1)  $I_{OUT,Th} = 0.5 \times I_{OUT,target}$  (typical)

## Short-Circuit Detection Principle (TLC5927 Only)

The LED short-circuit detection compares the effective voltage level  $V_{OUT}$  with the shorted-load detection threshold voltages  $V_{OUT,TTh}$  and  $V_{OUT,RTh}$ . If  $V_{OUT}$  is above the  $V_{OUT,TTh}$  threshold, the TLC5927 detects an shorted-load condition. If the  $V_{OUT}$  is below  $V_{OUT,RTh}$  threshold, no error is detected and the error bit is reset. This error status can be read as an error status code in the Special mode. For short-circuit error detection, a channel must be on.

**Table 2. Short-Circuit Detection**

STATE OF OUTPUT PORT	CONDITION OF OUTPUT VOLTAGE	ERROR STATUS CODE	MEANING
Off	$I_{OUT} = 0 \text{ mA}$	0	Detection not possible
On	$V_{OUT} < V_{OUT,TTh}^{(1)}$	0	Short circuit
	$V_{OUT} < V_{OUT,RTh}^{(1)}$	Channel n error status bit 1	Normal

(1)  $I_{OUT,Th} = 0.5 \times I_{OUT,target}$  (typical)

## Overtemperature Detection and Shutdown

The TLC5926/TLC5927 is equipped with a global overtemperature sensor and 16 individual, channel-specific overtemperature sensors.

- When the global sensor reaches the trip temperature, all output channels are shutdown, and the error status is stored in the internal Error Status register of every channel. After shutdown, the channels automatically restart after cooling down, if the control signal (output latch) remains on. The stored error status is not reset after cooling down and can be read out as the error status code in the Special mode.
- When one of the channel-specific sensors reaches trip temperature, only the affected output channel is shut down, and the error status is stored only in the internal Error Status register of the affected channel. After shutdown, the channel automatically restarts after cooling down, if the control signal (output latch) remains on. The stored error status is not reset after cooling down and can be read out as error status code in the Special mode.

For channel-specific overtemperature error detection, a channel must be on.

The error status code is reset when the TLC5926/TLC5927 returns to Normal mode.

**Table 3. Overtemperature Detection<sup>(1)</sup>**

STATE OF OUTPUT PORT	CONDITION	ERROR STATUS CODE	MEANING
Off	$I_{OUT} = 0 \text{ mA}$	0	
On	$T_j < T_{j,trip} \text{ global}$	1	Normal
On → all channels Off	$T_j > T_{j,trip} \text{ global}$	All error status bits = 0	Global overtemperature
On	$T_j < T_{j,trip} \text{ channel n}$	1	Normal
On → Off	$T_j > T_{j,trip} \text{ channel n}$	Channel n error status bit = 0	Channel n overtemperature

(1) The global shutdown threshold temperature is approximately 170°C.

## 16-Bit Configuration Code and Current Gain

Bit definition of the Configuration Code in the Configuration Latch is shown in [Table 4](#).

**Table 4. Bit Definition of 8-Bit Configuration Code**

	Bit 0	Bit 1	Bit 2	Bit 3	Bit 4	Bit 5	Bit 6	Bit 7	Bit 8–15
<b>Meaning</b>	CM	HC	CC0	CC1	CC2	CC3	CC4	CC5	Don't care
<b>Default</b>	1	1	1	1	1	1	1	1	X

Bit 7 is first sent into TLC5926/TLC5927 via SDI. Bits 1 to 7 {HC, CC[0:5]} determine the voltage gain (VG) that affects the voltage at R-EXT and indirectly affects the reference current,  $I_{ref}$ , flowing through the external resistor at R-EXT. Bit 0 is the Current Multiplier (CM) that determines the ratio  $I_{OUT,target}/I_{ref}$ . Each combination of VG and CM gives a specific Current Gain (CG).

- VG: the relationship between {HC,CC[0:5]} and the voltage gain is calculated as shown below:

$$VG = (1 + HC) \times (1 + D/64) / 4$$

$$D = CC0 \times 2^5 + CC1 \times 2^4 + CC2 \times 2^3 + CC3 \times 2^2 + CC4 \times 2^1 + CC5 \times 2^0$$

Where HC is 1 or 0, and D is the binary value of CC[0:5]. So, the VG could be regarded as a floating-point number with 1-bit exponent HC and 6-bit mantissa CC[0:5]. {HC,CC[0:5]} divides the programmable voltage gain VG into 128 steps and two sub-bands:

Low voltage sub-band (HC = 0):  $VG = 1/4 \sim 127/256$ , linearly divided into 64 steps

High voltage sub-band (HC = 1):  $VG = 1/2 \sim 127/128$ , linearly divided into 64 steps

- CM: In addition to determining the ratio  $I_{OUT,target}/I_{ref}$ , CM limits the output current range.

High Current Multiplier (CM = 1):  $I_{OUT,target}/I_{ref} = 15$ , suitable for output current range  $I_{OUT} = 10 \text{ mA}$  to  $120 \text{ mA}$ .

Low Current Multiplier (CM = 0):  $I_{OUT,target}/I_{ref} = 5$ , suitable for output current range  $I_{OUT} = 5 \text{ mA}$  to  $40 \text{ mA}$

- CG: The total Current Gain is defined as the following.

$$V_{R-EXT} = 1.26 \text{ V} \times VG$$

$$I_{ref} = V_{R-EXT}/R_{ext}, \text{ if the external resistor, } R_{ext}, \text{ is connected to ground.}$$

$$I_{OUT,target} = I_{ref} \times 15 \times 3^{CM-1} = 1.26 \text{ V}/R_{ext} \times VG \times 15 \times 3^{CM-1} = (1.26 \text{ V}/R_{ext} \times 15) \times CG$$

$$CG = VG \times 3^{CM-1}$$

Therefore,  $CG = (1/12)$  to  $(127/128)$  divided into 256 steps.

### Examples

- Configuration Code {CM, HC, CC[0:5]} = {1,1,111111}  
 $VG = 127/128 = 0.992$  and  $CG = VG \times 3^0 = VG = 0.992$
- Configuration Code = {1,1,000000}  
 $VG = (1 + 1) \times (1 + 0/64)/4 = 1/2 = 0.5$ , and  $CG = 0.5$
- Configuration Code = {0,0,000000}  
 $VG = (1 + 0) \times (1 + 0/64)/4 = 1/4$ , and  $CG = (1/4) \times 3^{-1} = 1/12$

After power on, the default value of the Configuration Code {CM, HC, CC[0:5]} is {1,1,111111}. Therefore,  $VG = CG = 0.992$ . The relationship between the Configuration Code and the Current Gain is shown in [Figure 15](#).

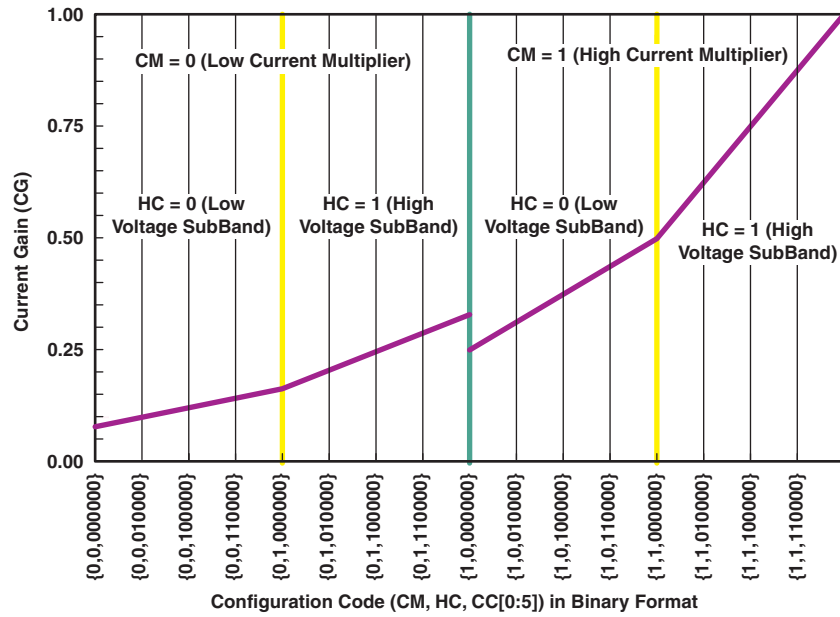

Figure 15. Current Gain vs Configuration Code

**PACKAGING INFORMATION**

Orderable Device	Status <sup>(1)</sup>	Package Type	Package Drawing	Pins	Package Qty	Eco Plan <sup>(2)</sup>	Lead/ Ball Finish	MSL Peak Temp <sup>(3)</sup>	Samples (Requires Login)
TLC5926IDBQR	ACTIVE	SSOP	DBQ	24	2500	Green (RoHS & no Sb/Br)	CU NIPDAU	Level-2-260C-1 YEAR	
TLC5926IDBQRG4	ACTIVE	SSOP	DBQ	24	2500	Green (RoHS & no Sb/Br)	CU NIPDAU	Level-2-260C-1 YEAR	
TLC5926IDWR	ACTIVE	SOIC	DW	24	2000	Green (RoHS & no Sb/Br)	CU NIPDAU	Level-1-260C-UNLIM	
TLC5926IPWPR	ACTIVE	HTSSOP	PWP	24	2000	Green (RoHS & no Sb/Br)	CU NIPDAU	Level-2-260C-1 YEAR	
TLC5926IPWPRG4	ACTIVE	HTSSOP	PWP	24	2000	Green (RoHS & no Sb/Br)	CU NIPDAU	Level-2-260C-1 YEAR	
TLC5927IDBQR	ACTIVE	SSOP	DBQ	24	2500	Green (RoHS & no Sb/Br)	CU NIPDAU	Level-2-260C-1 YEAR	
TLC5927IDBQRG4	ACTIVE	SSOP	DBQ	24	2500	Green (RoHS & no Sb/Br)	CU NIPDAU	Level-2-260C-1 YEAR	
TLC5927IDWR	ACTIVE	SOIC	DW	24	2000	Green (RoHS & no Sb/Br)	CU NIPDAU	Level-1-260C-UNLIM	
TLC5927IPWPR	ACTIVE	HTSSOP	PWP	24	2000	Green (RoHS & no Sb/Br)	CU NIPDAU	Level-2-260C-1 YEAR	
TLC5927IPWPRG4	ACTIVE	HTSSOP	PWP	24	2000	Green (RoHS & no Sb/Br)	CU NIPDAU	Level-2-260C-1 YEAR	

<sup>(1)</sup> The marketing status values are defined as follows:

**ACTIVE:** Product device recommended for new designs.

**LIFEBUY:** TI has announced that the device will be discontinued, and a lifetime-buy period is in effect.

**NRND:** Not recommended for new designs. Device is in production to support existing customers, but TI does not recommend using this part in a new design.

**PREVIEW:** Device has been announced but is not in production. Samples may or may not be available.

**OBSELETE:** TI has discontinued the production of the device.

<sup>(2)</sup> Eco Plan - The planned eco-friendly classification: Pb-Free (RoHS), Pb-Free (RoHS Exempt), or Green (RoHS & no Sb/Br) - please check <http://www.ti.com/productcontent> for the latest availability information and additional product content details.

**TBD:** The Pb-Free/Green conversion plan has not been defined.

**Pb-Free (RoHS):** TI's terms "Lead-Free" or "Pb-Free" mean semiconductor products that are compatible with the current RoHS requirements for all 6 substances, including the requirement that lead not exceed 0.1% by weight in homogeneous materials. Where designed to be soldered at high temperatures, TI Pb-Free products are suitable for use in specified lead-free processes.

**Pb-Free (RoHS Exempt):** This component has a RoHS exemption for either 1) lead-based flip-chip solder bumps used between the die and package, or 2) lead-based die adhesive used between the die and leadframe. The component is otherwise considered Pb-Free (RoHS compatible) as defined above.

---

**Green (RoHS & no Sb/Br):** TI defines "Green" to mean Pb-Free (RoHS compatible), and free of Bromine (Br) and Antimony (Sb) based flame retardants (Br or Sb do not exceed 0.1% by weight in homogeneous material)

<sup>(3)</sup> MSL, Peak Temp. -- The Moisture Sensitivity Level rating according to the JEDEC industry standard classifications, and peak solder temperature.

**Important Information and Disclaimer:** The information provided on this page represents TI's knowledge and belief as of the date that it is provided. TI bases its knowledge and belief on information provided by third parties, and makes no representation or warranty as to the accuracy of such information. Efforts are underway to better integrate information from third parties. TI has taken and continues to take reasonable steps to provide representative and accurate information but may not have conducted destructive testing or chemical analysis on incoming materials and chemicals. TI and TI suppliers consider certain information to be proprietary, and thus CAS numbers and other limited information may not be available for release.

In no event shall TI's liability arising out of such information exceed the total purchase price of the TI part(s) at issue in this document sold by TI to Customer on an annual basis.

**OTHER QUALIFIED VERSIONS OF TLC5926, TLC5927 :**

- Automotive: [TLC5926-Q1](#), [TLC5927-Q1](#)

NOTE: Qualified Version Definitions:

- Automotive - Q100 devices qualified for high-reliability automotive applications targeting zero defects

**TAPE AND REEL INFORMATION**
**REEL DIMENSIONS**

**TAPE DIMENSIONS**

A0	Dimension designed to accommodate the component width
B0	Dimension designed to accommodate the component length
K0	Dimension designed to accommodate the component thickness
W	Overall width of the carrier tape
P1	Pitch between successive cavity centers

**TAPE AND REEL INFORMATION**

\*All dimensions are nominal

Device	Package Type	Package Drawing	Pins	SPQ	Reel Diameter (mm)	Reel Width W1 (mm)	A0 (mm)	B0 (mm)	K0 (mm)	P1 (mm)	W (mm)	Pin1 Quadrant
TLC5926IDBQR	SSOP	DBQ	24	2500	330.0	16.4	6.5	9.0	2.1	8.0	16.0	Q1
TLC5926IDWR	SOIC	DW	24	2000	330.0	24.4	10.75	15.7	2.7	12.0	24.0	Q1
TLC5926IPWPR	HTSSOP	PWP	24	2000	330.0	16.4	6.95	8.3	1.6	8.0	16.0	Q1
TLC5927IDBQR	SSOP	DBQ	24	2500	330.0	16.4	6.5	9.0	2.1	8.0	16.0	Q1
TLC5927IDWR	SOIC	DW	24	2000	330.0	24.4	10.75	15.7	2.7	12.0	24.0	Q1
TLC5927IPWPR	HTSSOP	PWP	24	2000	330.0	16.4	6.95	8.3	1.6	8.0	16.0	Q1

**TAPE AND REEL BOX DIMENSIONS**

\*All dimensions are nominal

Device	Package Type	Package Drawing	Pins	SPQ	Length (mm)	Width (mm)	Height (mm)
TLC5926IDBQR	SSOP	DBQ	24	2500	367.0	367.0	38.0
TLC5926IDWR	SOIC	DW	24	2000	367.0	367.0	45.0
TLC5926IPWPR	HTSSOP	PWP	24	2000	367.0	367.0	38.0
TLC5927IDBQR	SSOP	DBQ	24	2500	367.0	367.0	38.0
TLC5927IDWR	SOIC	DW	24	2000	367.0	367.0	45.0
TLC5927IPWPR	HTSSOP	PWP	24	2000	367.0	367.0	38.0



DW (R-PDSO-G24)

PLASTIC SMALL OUTLINE



- NOTES:
- All linear dimensions are in inches (millimeters). Dimensioning and tolerancing per ASME Y14.5M-1994.
  - This drawing is subject to change without notice.
  - Body dimensions do not include mold flash or protrusion not to exceed 0.006 (0,15).
  - Falls within JEDEC MS-013 variation AD.

DW (R-PDSO-G24)

PLASTIC SMALL OUTLINE

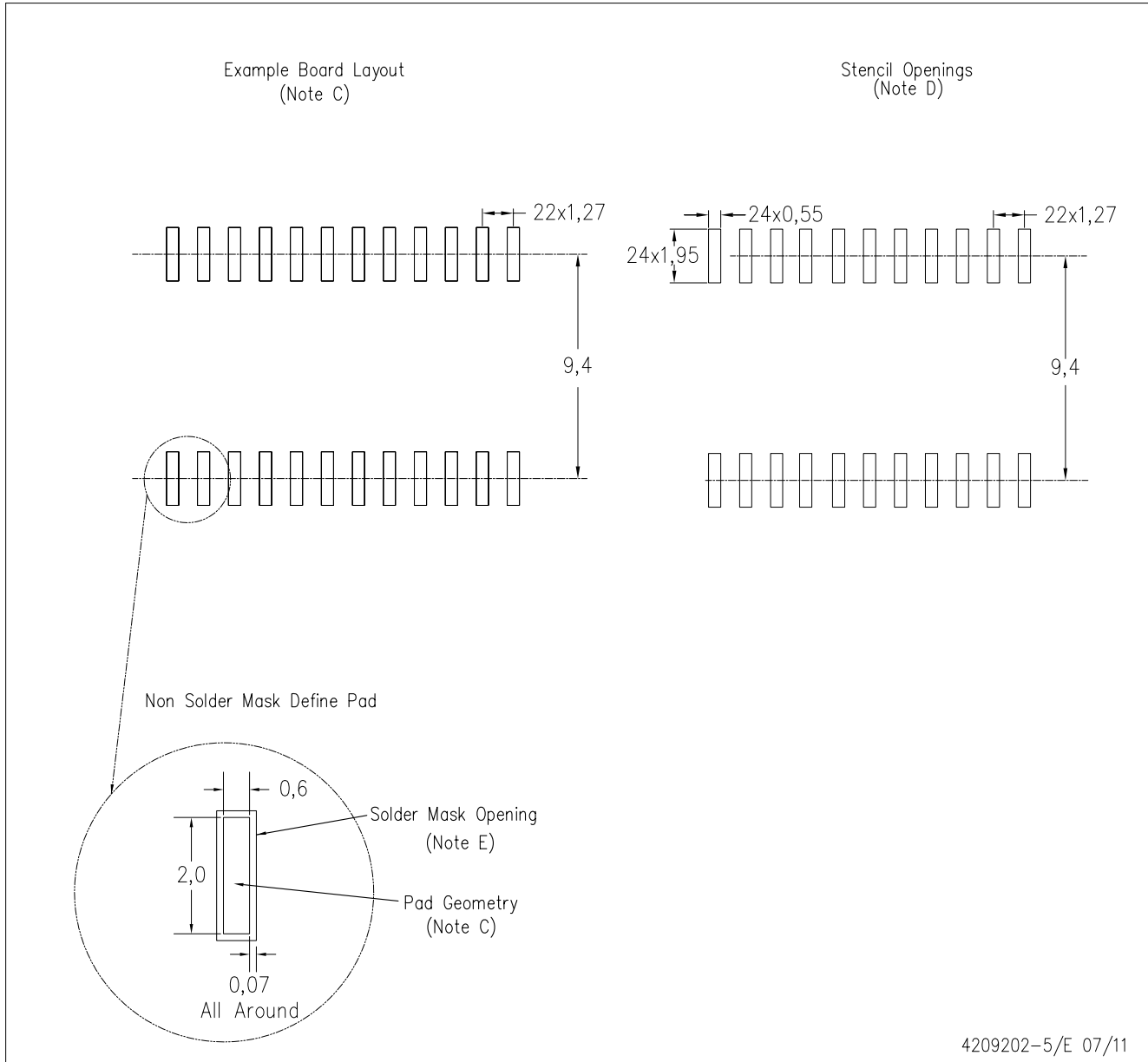

- NOTES:
- A. All linear dimensions are in millimeters.
  - B. This drawing is subject to change without notice.
  - C. Refer to IPC7351 for alternate board design.
  - D. Laser cutting apertures with trapezoidal walls and also rounding corners will offer better paste release. Customers should contact their board assembly site for stencil design recommendations. Refer to IPC-7525
  - E. Customers should contact their board fabrication site for solder mask tolerances between and around signal pads.



DBQ (R-PDSO-G24)

PLASTIC SMALL OUTLINE PACKAGE

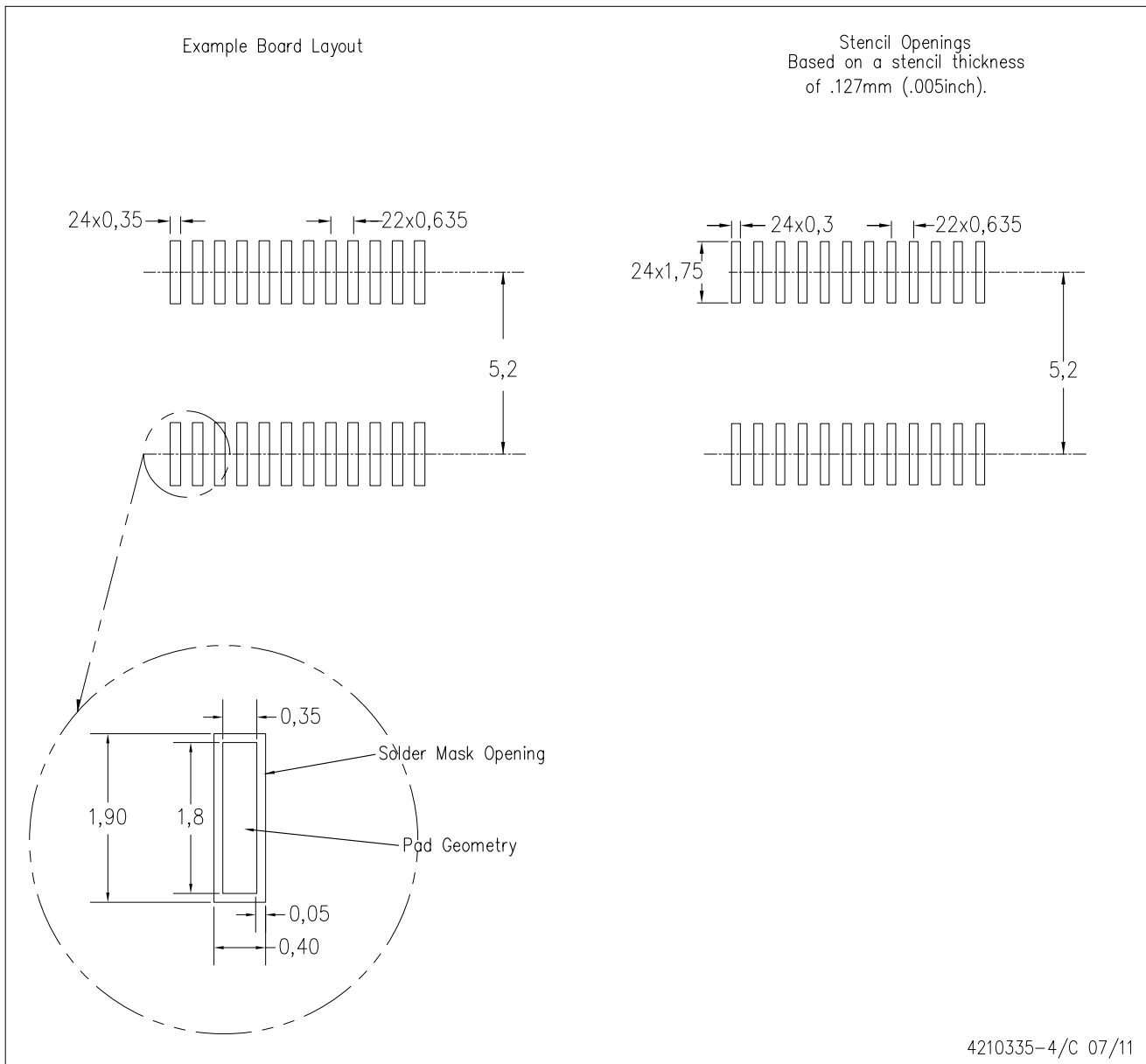

- NOTES:
- A. All linear dimensions are in millimeters.
  - B. This drawing is subject to change without notice.
  - C. Customers should place a note on the circuit board fabrication drawing not to alter the center solder mask defined pad.
  - D. Publication IPC-7351 is recommended for alternate designs.
  - E. Laser cutting apertures with trapezoidal walls and also rounding corners will offer better paste release. Customers should contact their board assembly site for stencil design recommendations. Example stencil design based on a 50% volumetric metal load solder paste. Refer to IPC-7525 for other stencil recommendations.

# MECHANICAL DATA

PWP (R-PDSO-G24)

PowerPAD™ PLASTIC SMALL OUTLINE

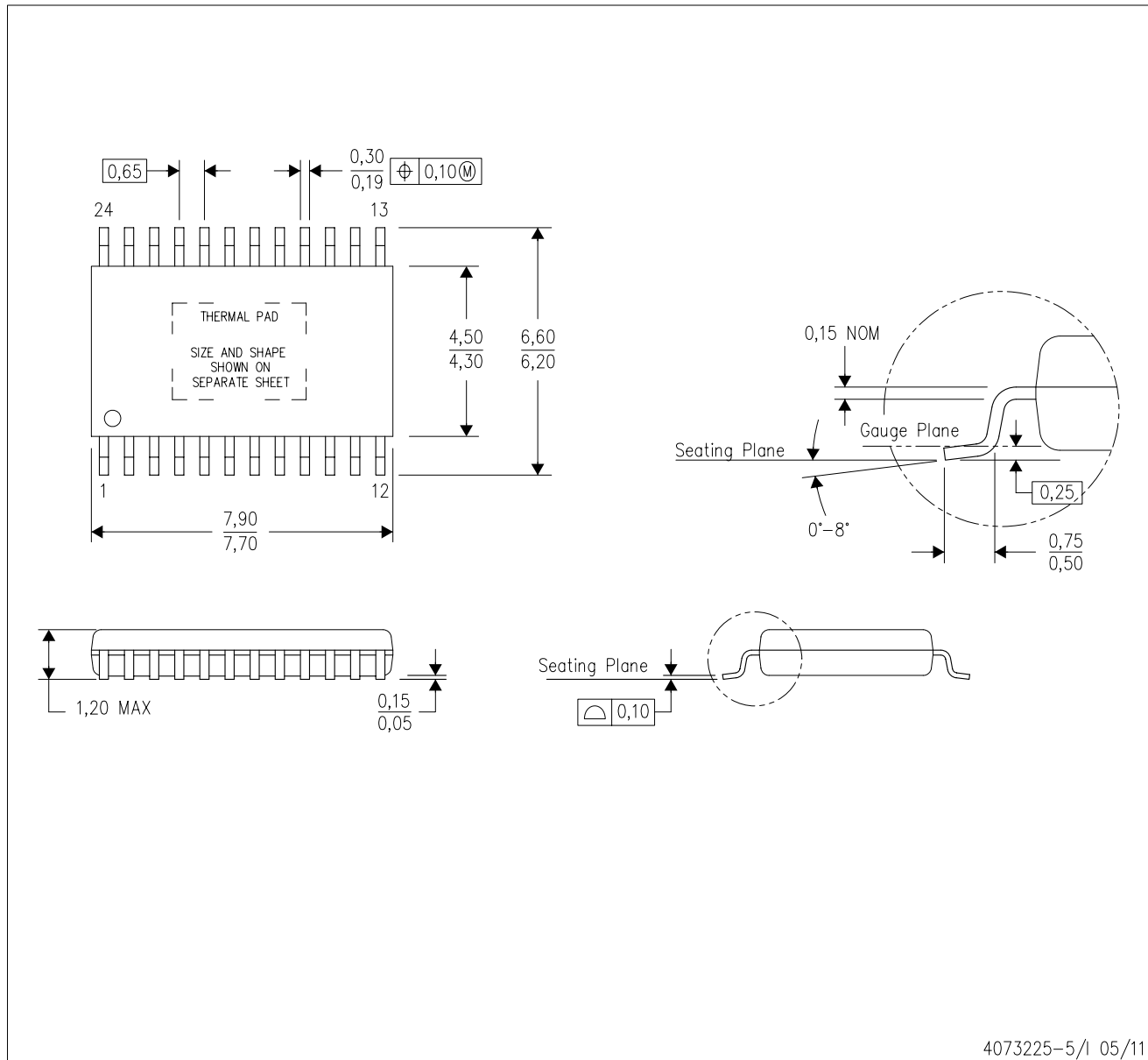

- NOTES:
- All linear dimensions are in millimeters.
  - This drawing is subject to change without notice.
  - Body dimensions do not include mold flash or protrusions. Mold flash and protrusion shall not exceed 0.15 per side.
  - This package is designed to be soldered to a thermal pad on the board. Refer to Technical Brief, PowerPad Thermally Enhanced Package, Texas Instruments Literature No. SLMA002 for information regarding recommended board layout. This document is available at [www.ti.com](http://www.ti.com) <<http://www.ti.com>>.
  - See the additional figure in the Product Data Sheet for details regarding the exposed thermal pad features and dimensions.
  - Falls within JEDEC MO-153

PowerPAD is a trademark of Texas Instruments.

## THERMAL PAD MECHANICAL DATA

### PWP (R-PDSO-G24) PowerPAD™ SMALL PLASTIC OUTLINE

#### THERMAL INFORMATION

This PowerPAD™ package incorporates an exposed thermal pad that is designed to be attached to a printed circuit board (PCB). The thermal pad must be soldered directly to the PCB. After soldering, the PCB can be used as a heatsink. In addition, through the use of thermal vias, the thermal pad can be attached directly to the appropriate copper plane shown in the electrical schematic for the device, or alternatively, can be attached to a special heatsink structure designed into the PCB. This design optimizes the heat transfer from the integrated circuit (IC).

For additional information on the PowerPAD package and how to take advantage of its heat dissipating abilities, refer to Technical Brief, PowerPAD Thermally Enhanced Package, Texas Instruments Literature No. SLMA002 and Application Brief, PowerPAD Made Easy, Texas Instruments Literature No. SLMA004. Both documents are available at [www.ti.com](http://www.ti.com).

The exposed thermal pad dimensions for this package are shown in the following illustration.

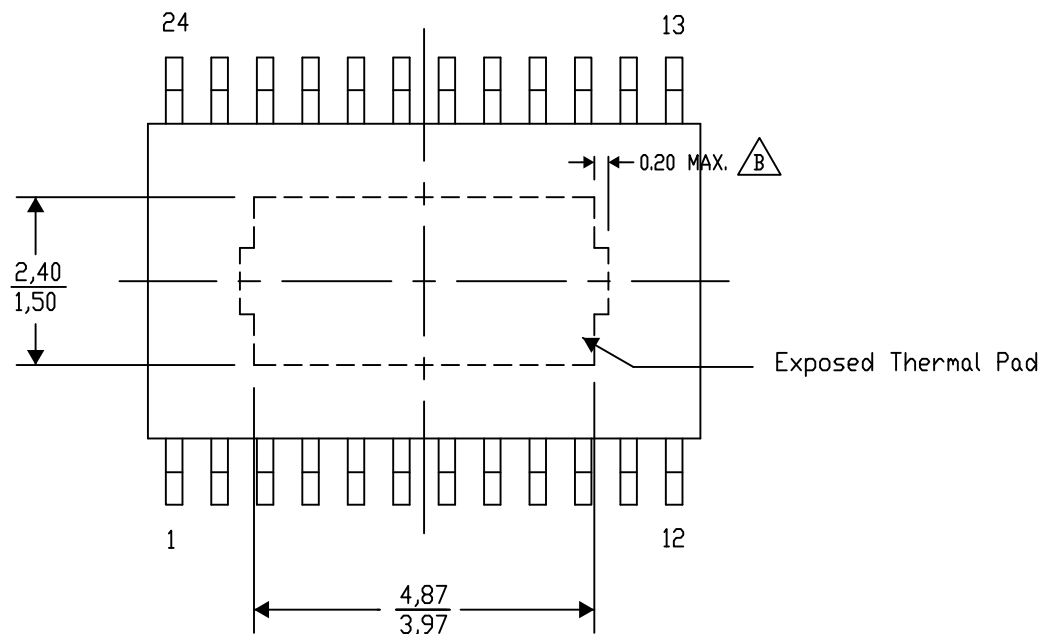

4206332-29/AC 07/12

NOTE: A. All linear dimensions are in millimeters

 B. Exposed tie strap features may not be present.

PowerPAD is a trademark of Texas Instruments

PWP (R-PDSO-G24)

PowerPAD™ PLASTIC SMALL OUTLINE

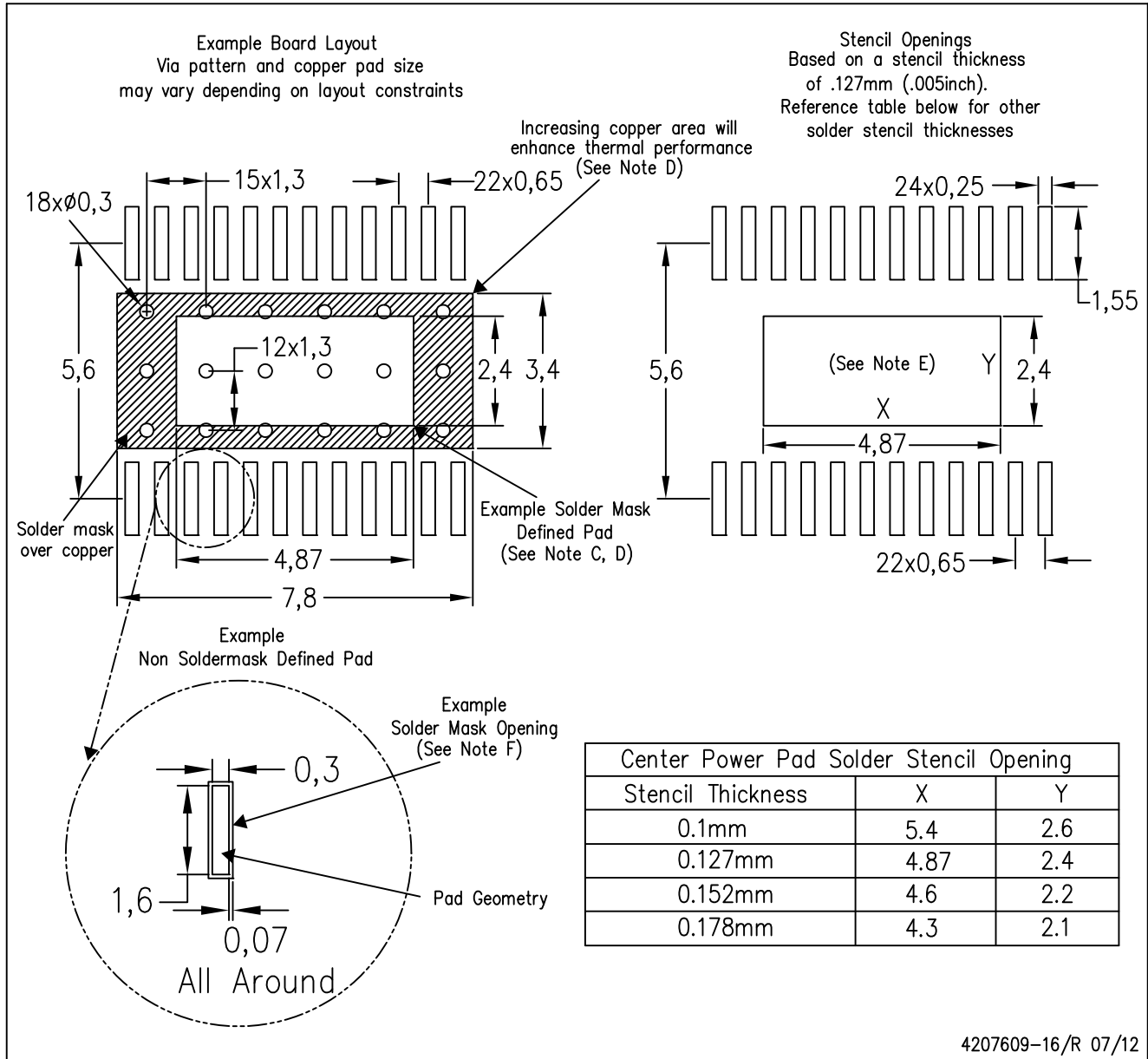

- NOTES:
- A. All linear dimensions are in millimeters.
  - B. This drawing is subject to change without notice.
  - C. Customers should place a note on the circuit board fabrication drawing not to alter the center solder mask defined pad.
  - D. This package is designed to be soldered to a thermal pad on the board. Refer to Technical Brief, PowerPad Thermally Enhanced Package, Texas Instruments Literature No. SLMA002, SLMA004, and also the Product Data Sheets for specific thermal information, via requirements, and recommended board layout. These documents are available at [www.ti.com](http://www.ti.com) <<http://www.ti.com>>. Publication IPC-7351 is recommended for alternate designs.
  - E. Laser cutting apertures with trapezoidal walls and also rounding corners will offer better paste release. Customers should contact their board assembly site for stencil design recommendations. Example stencil design based on a 50% volumetric metal load solder paste. Refer to IPC-7525 for other stencil recommendations.
  - F. Customers should contact their board fabrication site for solder mask tolerances between and around signal pads.

## IMPORTANT NOTICE

Texas Instruments Incorporated and its subsidiaries (TI) reserve the right to make corrections, enhancements, improvements and other changes to its semiconductor products and services per JESD46C and to discontinue any product or service per JESD48B. Buyers should obtain the latest relevant information before placing orders and should verify that such information is current and complete. All semiconductor products (also referred to herein as "components") are sold subject to TI's terms and conditions of sale supplied at the time of order acknowledgment.

TI warrants performance of its components to the specifications applicable at the time of sale, in accordance with the warranty in TI's terms and conditions of sale of semiconductor products. Testing and other quality control techniques are used to the extent TI deems necessary to support this warranty. Except where mandated by applicable law, testing of all parameters of each component is not necessarily performed.

TI assumes no liability for applications assistance or the design of Buyers' products. Buyers are responsible for their products and applications using TI components. To minimize the risks associated with Buyers' products and applications, Buyers should provide adequate design and operating safeguards.

TI does not warrant or represent that any license, either express or implied, is granted under any patent right, copyright, mask work right, or other intellectual property right relating to any combination, machine, or process in which TI components or services are used. Information published by TI regarding third-party products or services does not constitute a license to use such products or services or a warranty or endorsement thereof. Use of such information may require a license from a third party under the patents or other intellectual property of the third party, or a license from TI under the patents or other intellectual property of TI.

Reproduction of significant portions of TI information in TI data books or data sheets is permissible only if reproduction is without alteration and is accompanied by all associated warranties, conditions, limitations, and notices. TI is not responsible or liable for such altered documentation. Information of third parties may be subject to additional restrictions.

Resale of TI components or services with statements different from or beyond the parameters stated by TI for that component or service voids all express and any implied warranties for the associated TI component or service and is an unfair and deceptive business practice. TI is not responsible or liable for any such statements.

Buyer acknowledges and agrees that it is solely responsible for compliance with all legal, regulatory and safety-related requirements concerning its products, and any use of TI components in its applications, notwithstanding any applications-related information or support that may be provided by TI. Buyer represents and agrees that it has all the necessary expertise to create and implement safeguards which anticipate dangerous consequences of failures, monitor failures and their consequences, lessen the likelihood of failures that might cause harm and take appropriate remedial actions. Buyer will fully indemnify TI and its representatives against any damages arising out of the use of any TI components in safety-critical applications.

In some cases, TI components may be promoted specifically to facilitate safety-related applications. With such components, TI's goal is to help enable customers to design and create their own end-product solutions that meet applicable functional safety standards and requirements. Nonetheless, such components are subject to these terms.

No TI components are authorized for use in FDA Class III (or similar life-critical medical equipment) unless authorized officers of the parties have executed a special agreement specifically governing such use.

Only those TI components which TI has specifically designated as military grade or "enhanced plastic" are designed and intended for use in military/aerospace applications or environments. Buyer acknowledges and agrees that any military or aerospace use of TI components which have **not** been so designated is solely at the Buyer's risk, and that Buyer is solely responsible for compliance with all legal and regulatory requirements in connection with such use.

TI has specifically designated certain components which meet ISO/TS16949 requirements, mainly for automotive use. Components which have not been so designated are neither designed nor intended for automotive use; and TI will not be responsible for any failure of such components to meet such requirements.

### Products

Audio	<a href="http://www.ti.com/audio">www.ti.com/audio</a>
Amplifiers	<a href="http://amplifier.ti.com">amplifier.ti.com</a>
Data Converters	<a href="http://dataconverter.ti.com">dataconverter.ti.com</a>
DLP® Products	<a href="http://www.dlp.com">www.dlp.com</a>
DSP	<a href="http://dsp.ti.com">dsp.ti.com</a>
Clocks and Timers	<a href="http://www.ti.com/clocks">www.ti.com/clocks</a>
Interface	<a href="http://interface.ti.com">interface.ti.com</a>
Logic	<a href="http://logic.ti.com">logic.ti.com</a>
Power Mgmt	<a href="http://power.ti.com">power.ti.com</a>
Microcontrollers	<a href="http://microcontroller.ti.com">microcontroller.ti.com</a>
RFID	<a href="http://www.ti-rfid.com">www.ti-rfid.com</a>
OMAP Mobile Processors	<a href="http://www.ti.com/omap">www.ti.com/omap</a>
Wireless Connectivity	<a href="http://www.ti.com/wirelessconnectivity">www.ti.com/wirelessconnectivity</a>

### Applications

Automotive and Transportation	<a href="http://www.ti.com/automotive">www.ti.com/automotive</a>
Communications and Telecom	<a href="http://www.ti.com/communications">www.ti.com/communications</a>
Computers and Peripherals	<a href="http://www.ti.com/computers">www.ti.com/computers</a>
Consumer Electronics	<a href="http://www.ti.com/consumer-apps">www.ti.com/consumer-apps</a>
Energy and Lighting	<a href="http://www.ti.com/energy">www.ti.com/energy</a>
Industrial	<a href="http://www.ti.com/industrial">www.ti.com/industrial</a>
Medical	<a href="http://www.ti.com/medical">www.ti.com/medical</a>
Security	<a href="http://www.ti.com/security">www.ti.com/security</a>
Space, Avionics and Defense	<a href="http://www.ti.com/space-avionics-defense">www.ti.com/space-avionics-defense</a>
Video and Imaging	<a href="http://www.ti.com/video">www.ti.com/video</a>

**TI E2E Community** [e2e.ti.com](http://e2e.ti.com)