

### Features

- Max. driver current 1 A
- Integrated free-wheeling diodes
- Short-circuit proof to ground
- Inhibit
- ESD protected inputs
- Temperature range  $-40\text{ °C} \leq T_j \leq 150\text{ °C}$

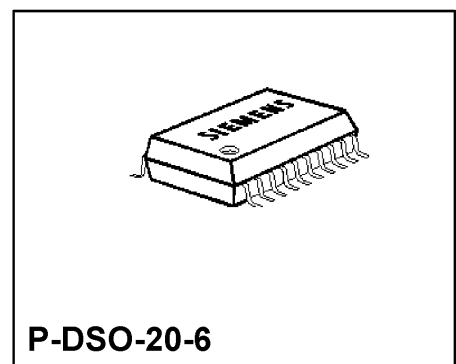
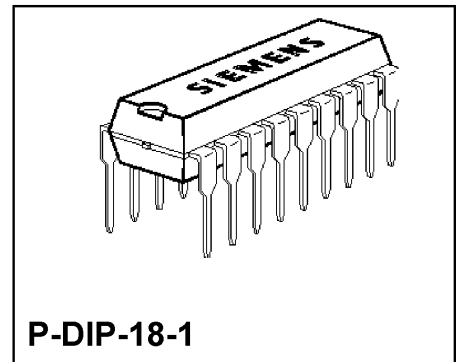

Type	Ordering Code	Package
TLE 4205	Q67000-A9025	P-DIP-18-1
▼ TLE 4205 G	Q67000-A9114	P-DSO-20-6 (SMD)

▼ New type

TLE 4205 is an integrated power full-bridge DC-motor driver for a wide temperature range, as required in automotive applications for example. The circuit contains two power comparators that can be combined to a full-bridge circuit. For inductive loads there are integrated free-wheeling diodes to  $+V_S$  and ground. The outputs are short-circuit proof from 18 V to ground and turn-OFF when overtemperature occurs. This IC is especially suitable for headlight-beam adjustment in automobiles.

## Pin Configuration (top view)

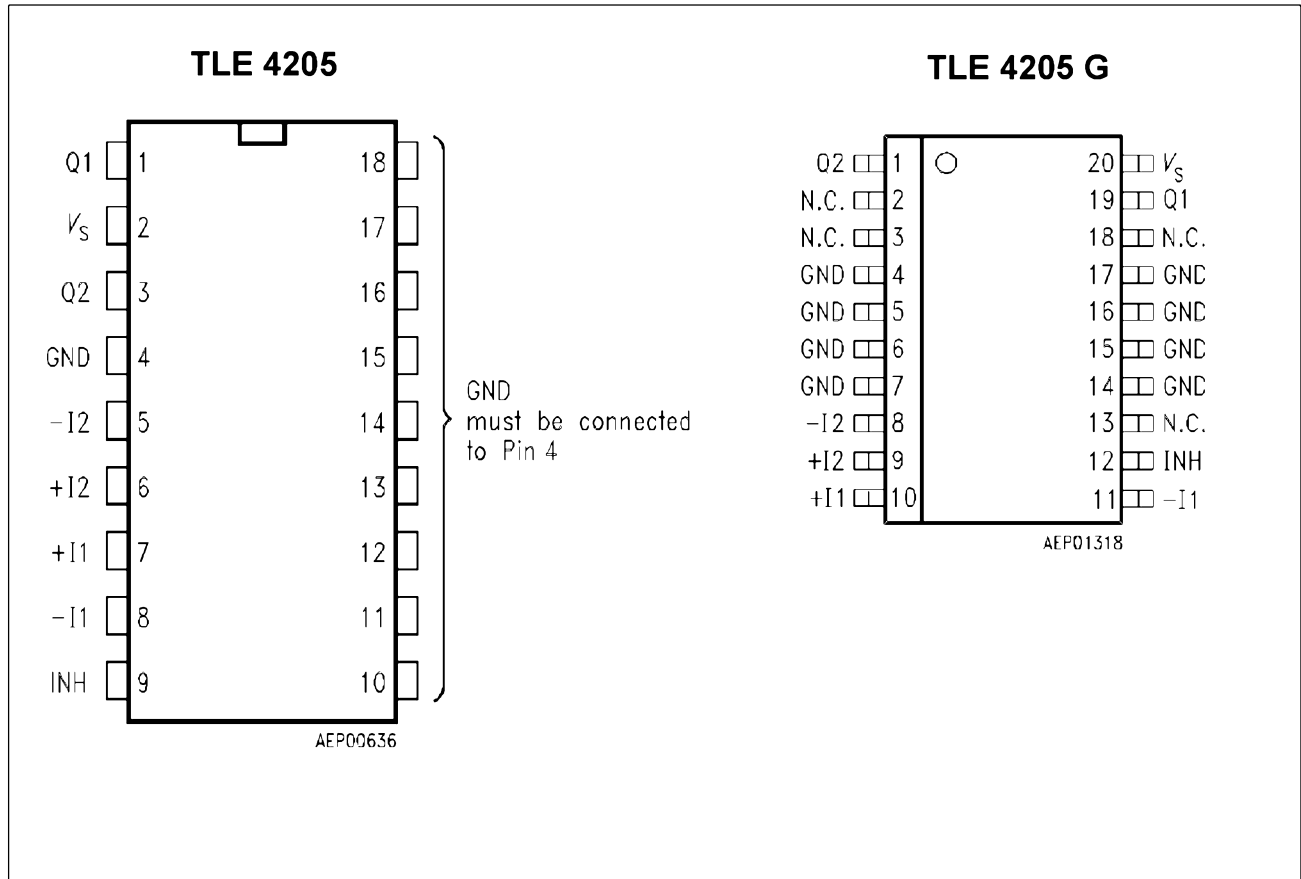

## Pin Definitions and Functions (TLE 4205)

Pin	Symbol	Function
1	Q1	<b>Output Q1 of channel 1</b> ; push-pull B output with DC short-circuit protection to ground. Integrated free-wheeling diodes to ground and the supply voltage.
2	$V_S$	<b>Supply voltage <math>V_S</math></b> ; must be blocked to ground with a ceramic capacitor of at least 100 nF directly on the pins of the IC.
3	Q2	<b>Output Q2 of channel 2</b> ; see pin 1.
4	GND	<b>Ground</b>
5	- I2	<b>Inverting input channel 2</b> ; to be wired according to general rules.
6	+ I2	<b>Non-inverting input channel 2</b> ; to be wired according to general rules.
7	+ I1	<b>Non-inverting input channel 1</b> ; see pin 6.
8	- I1	<b>Inverting input channel 1</b> ; see pin 5.
9	INH	<b>Inhibit</b> ; the IC is passive when this pin is open or connected to ground.
10-18	GND	<b>Ground</b> ; must be connected to pin 4.

## Pin Definitions and Functions (TLE 4205 G)

Pin	Symbol	Function
1	Q2	<b>Output 2 of channel 2;</b> push-pull B output with DC short-circuit protection to ground. Integrated free-wheeling diodes to ground and the supply voltage.
2	N.C.	Not connected
3	N.C.	Not connected
4-7	GND	<b>Ground</b>
8	- I2	<b>Inverting input channel 2;</b> to be wired according to general rules.
9	+ I2	<b>Non-inverting input channel 2;</b> to be wired according to general rules.
10	+ I1	<b>Non-inverting input channel 1;</b> see pin 6.
11	- I1	<b>Inverting input channel 1;</b> see pin 5.
12	INH	<b>Inhibit;</b> the IC is passive when this pin is open or connected to ground.
13	N.C.	Not connected
14-17	GND	<b>Ground</b>
18	N.C.	Not connected
19	Q1	<b>Output Q1;</b> must be connected to pin 4.
20	$V_S$	<b>Supply voltage;</b> must be connected to pin 4.

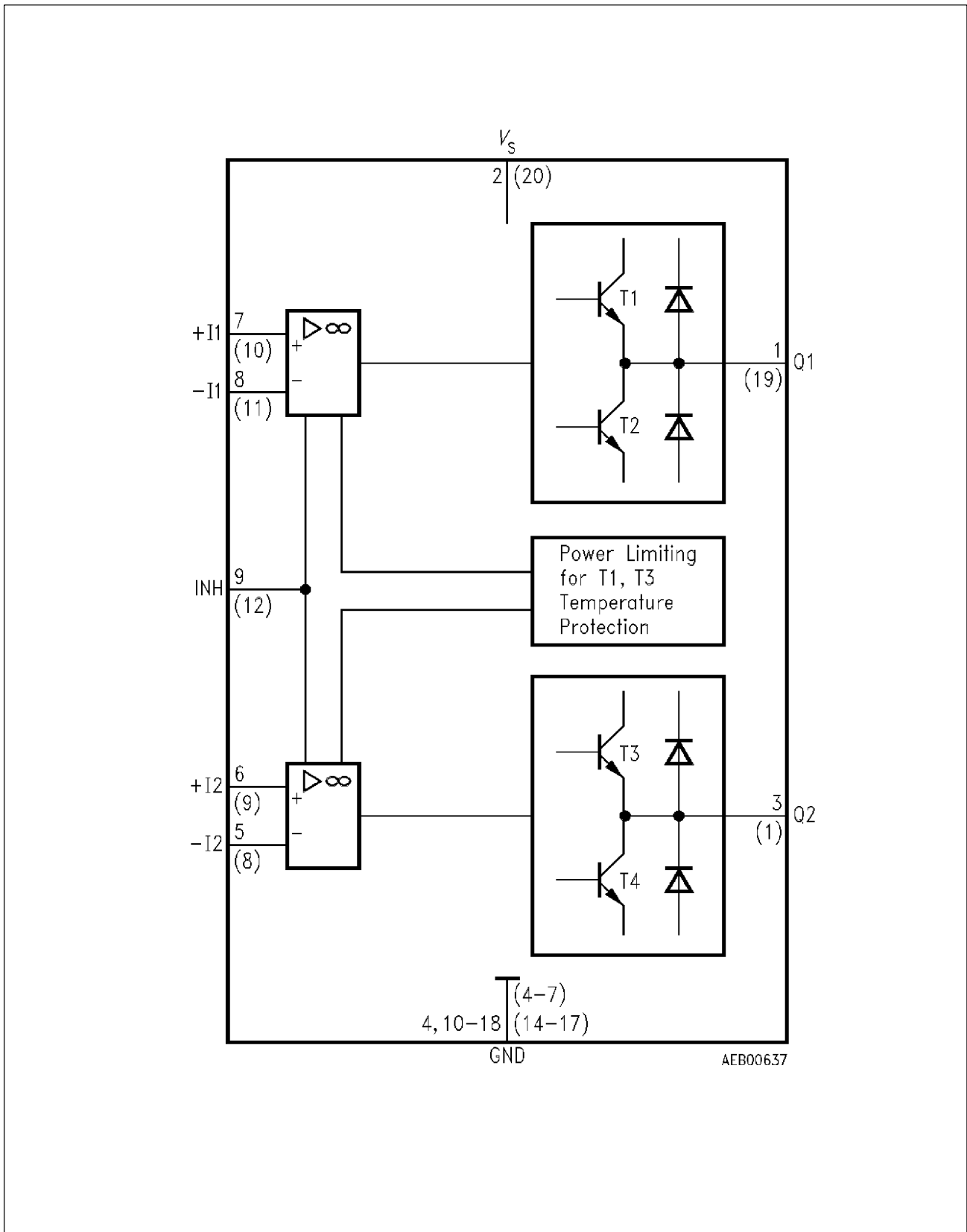

Block Diagram

**Circuit Description**

The IC contains two amplifiers with typical open-loop gain of 80 dB at 500 Hz.

The input stages consist of PNP-differential amplifiers. This produces a common-mode input range of 0 V to nearly  $V_S$  and a maximum differential input voltage of  $V_S$ . The IC is guarded against ground shorts by an SOA-protective circuit. The output transistors are turned off if the chip temperature exceeds approx. 160 °C. The IC can be turned off by an inhibit input, which very much reduces current consumption.

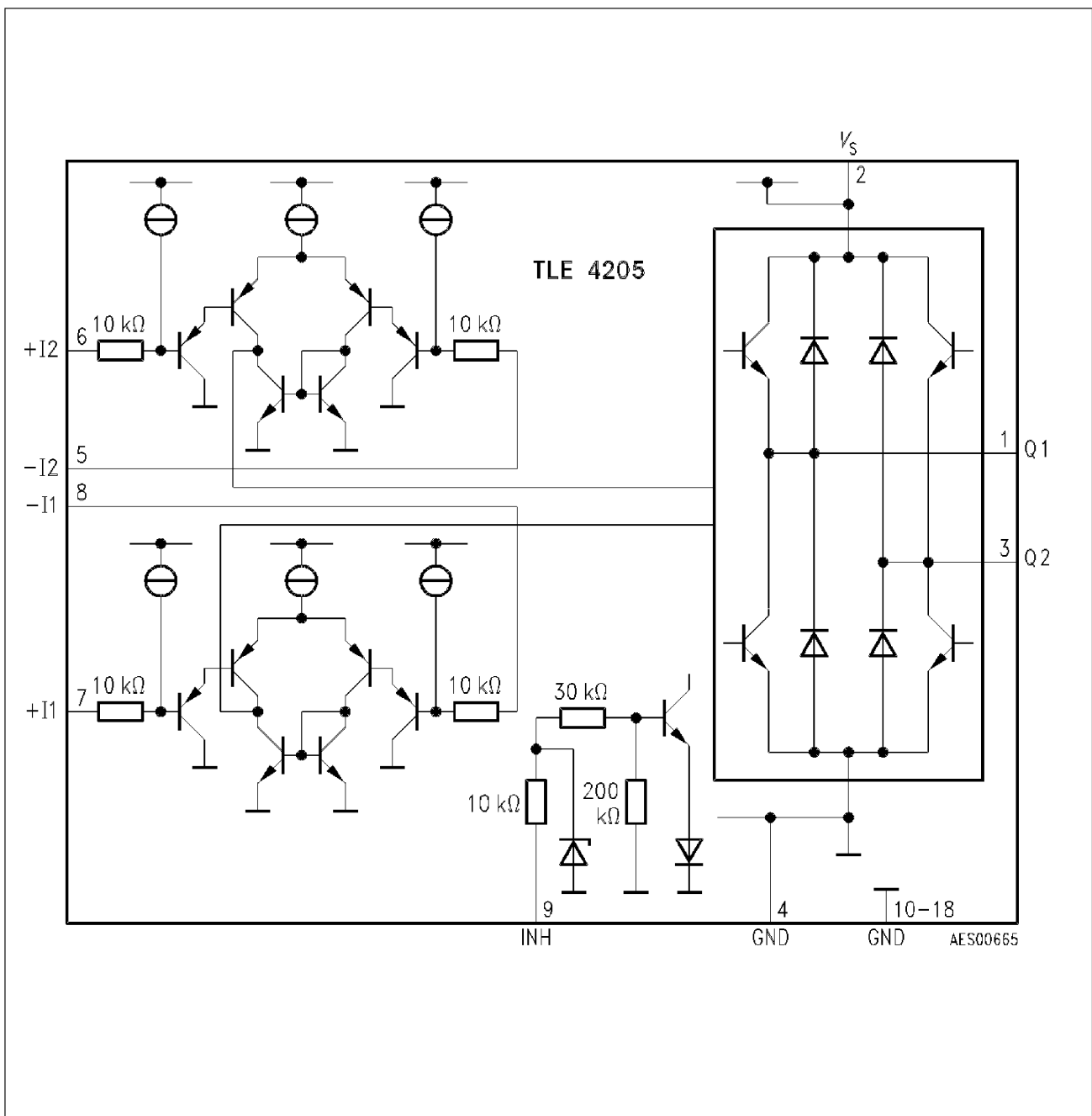

**Circuit Diagram**

## Absolute Maximum Ratings

$T_j = -40$  to  $150$  °C

Parameter	Symbol	Limit Values		Unit	Remarks
		min.	max.		
Supply voltage	$V_S$	- 0.3	45	V	
Differential input voltage	$V_{ID}$		$\pm V_S$	V	$\Delta V_{6-5}$ or $\Delta V_{7-8}$ TLE 4205 $\Delta V_{8-9}$ or $\Delta V_{10-11}$ TLE 4205 G
Output current	$I_Q$	- 1	1	A	
Supply current	$I_S$	2.5	3	A	
Ground current	$I_{GND}$	- 3	2.5	A	I2
Input voltage	$V_I$	- 15	+ $V_S$	V	$V_5; V_6; V_7; V_8$ TLE 4205 $V_8; V_9; V_{10}; V_{11}$ TLE 4205 G
Inhibit input	$V_9$	- 15	+ $V_S$	V	
Junction temperature	$T_j$		150	°C	
Storage temperature	$T_{stg}$	- 50	150	°C	

## Operating Range

Supply voltage	$V_S$	6	32	V	
Case temperature	$T_C$	- 40	105	°C	$P_{Dmax} = 3$ W
Thermal resistance junction - ambient	$R_{th JA}$		60	K/W	TLE 4205
junction - case	$R_{th JC}$		15	K/W	TLE 4205
Thermal resistance junction - ambient	$R_{th JA}$		65	K/W	TLE 4205 G
junction - case	$R_{th JC}$		3	K/W	TLE 4205 G

Outputs pin 1 and pin 3 short-circuit proof to GND at  $V_S \leq 18$  V

## Characteristics

$V_S = 13.5 \text{ V}; T_j = 25 \text{ }^\circ\text{C}$

Parameter	Symbol	Limit Values			Unit	Test Condition
		min.	typ.	max.		

## General

Open-circuit current consumption	$I_S$		10	30	mA	active
Open-circuit current consumption	$I_S$		10	100	$\mu\text{A}$	inhibit
Turn-ON dead time ref. to $V_{9\text{ OFF/ON}}$	$t_{d\text{ ON}}$		10	20	$\mu\text{s}$	$ I_{1,3}  < 1 \text{ A}$ TLE 4205 $ I_{1,19}  < 1 \text{ A}$ TLE 4205 G
Turn-OFF dead time ref. to $V_{9\text{ OFF/ON}}$	$t_{d\text{ OFF}}$		10	20	$\mu\text{s}$	$ I_{1,3}  < 1 \text{ A}$ TLE 4205 $ I_{1,19}  < 1 \text{ A}$ TLE 4205 G
Open-loop gain	$G_{VO}$	50	80		dB	$f = 500 \text{ Hz}$

## Inputs

Input zero voltage	$V_{IO}$	- 7.5		7.5	mV	$R_S = 10 \text{ k}\Omega;$ $- 40 \text{ }^\circ\text{C} \leq T_j \leq 85 \text{ }^\circ\text{C}$
Input-voltage drift	$\Delta V_{IO}/\Delta T$		20	30	$\mu\text{V/K}$	$- 40 \text{ }^\circ\text{C} \leq T_j \leq 85 \text{ }^\circ\text{C}$
Input zero current	$I_{IO}$	- 75		75	mA	$- 40 \text{ }^\circ\text{C} \leq T_j \leq 85 \text{ }^\circ\text{C}$
Input current	$I_I$	- 300		300	nA	$- 40 \text{ }^\circ\text{C} \leq T_j \leq 85 \text{ }^\circ\text{C}$
Input-current drift	$\Delta I_I/\Delta T$			5	nA/K	$- 40 \text{ }^\circ\text{C} \leq T_j \leq 85 \text{ }^\circ\text{C}$
Input common-mode range, positive	$V_{IC}$			$V_S - 2$	V	
Input common-mode range, negative	$V_{IC}$			- 0.5	V	



## Characteristics (cont'd)

$V_S = 13.5 \text{ V}; T_j = 25 \text{ }^\circ\text{C}$

Parameter	Symbol	Limit Values			Unit	Test Condition
		min.	typ.	max.		
Power-supply rejection ratio	$PSSR$			200	$\mu\text{V/V}$	$R_S = 10 \text{ k}\Omega;$ $-40 \text{ }^\circ\text{C} \leq T_j \leq 85 \text{ }^\circ\text{C}$
Common-mode rejection ratio	$CMRR$	70	80		dB	

## Outputs

Saturation voltage	$V_{\text{Satu}}$		1.0	1.5	V	$I_Q = 0.6 \text{ A};$ $-40 \text{ }^\circ\text{C} \leq T_j \leq 85 \text{ }^\circ\text{C}$
Saturation voltage	$V_{\text{Sat1}}$		1.0	1.5	V	$I_Q = 0.6 \text{ A};$ $-40 \text{ }^\circ\text{C} \leq T_j \leq 85 \text{ }^\circ\text{C}$
Forward voltage of free-wheeling diode	$V_{\text{Fu}}$		1.0	1.5	V	$I_Q = 0.6 \text{ A};$ $-40 \text{ }^\circ\text{C} \leq T_j \leq 85 \text{ }^\circ\text{C}$
Forward voltage of free-wheeling diode	$V_{\text{F1}}$		1.0	1.5	V	$I_Q = 0.6 \text{ A};$ $-40 \text{ }^\circ\text{C} \leq T_j \leq 85 \text{ }^\circ\text{C}$
Slew rate of $V_Q$	$dV_Q/dt_r$		0.5		V/ $\mu\text{s}$	

## Inhibit Input

Switching threshold high	$V_{\text{IH}}$	2			V	
Switching threshold low	$V_{\text{IL}}$			0.8	V	
H-input current	$I_{\text{IH}}$		100		$\mu\text{A}$	$V_9 = 5 \text{ V}$
L-input current	$I_{\text{IH}}$		0		$\mu\text{A}$	$V_9 = 0 \text{ V}$

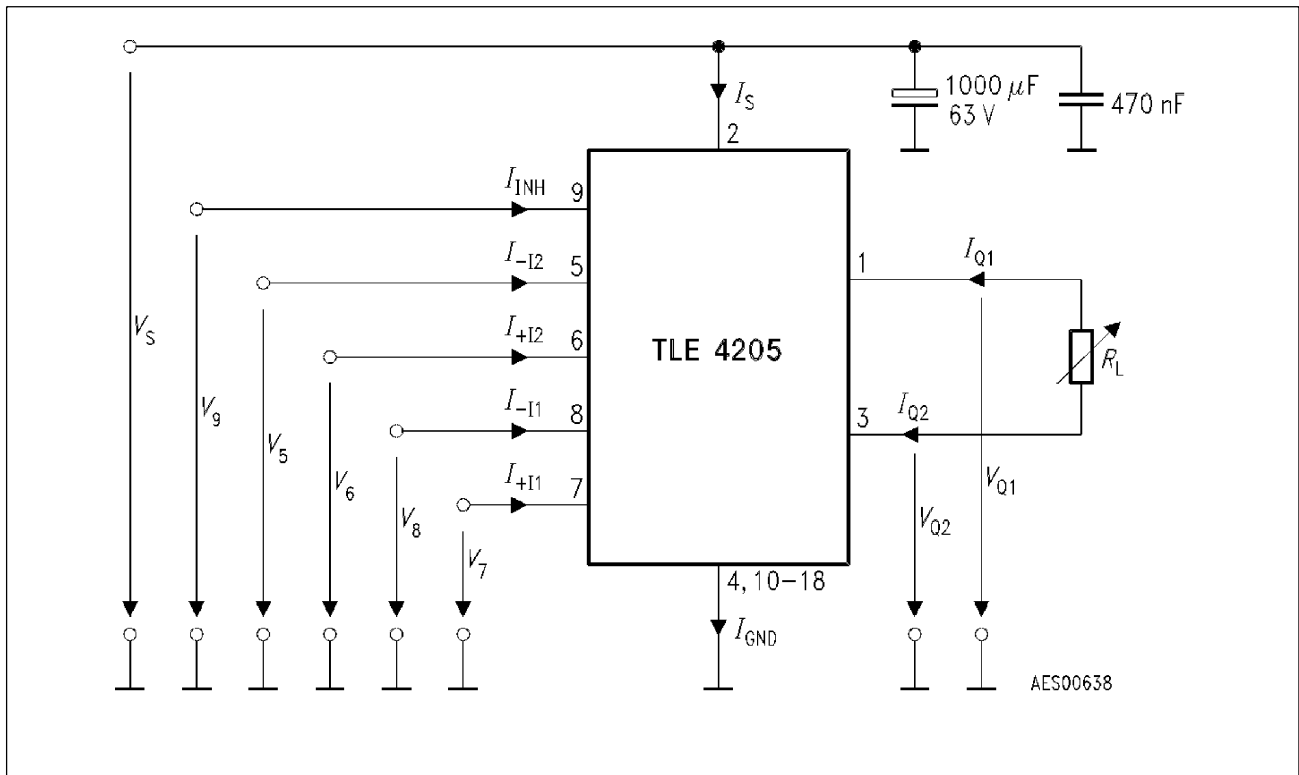

**Test Circuit**

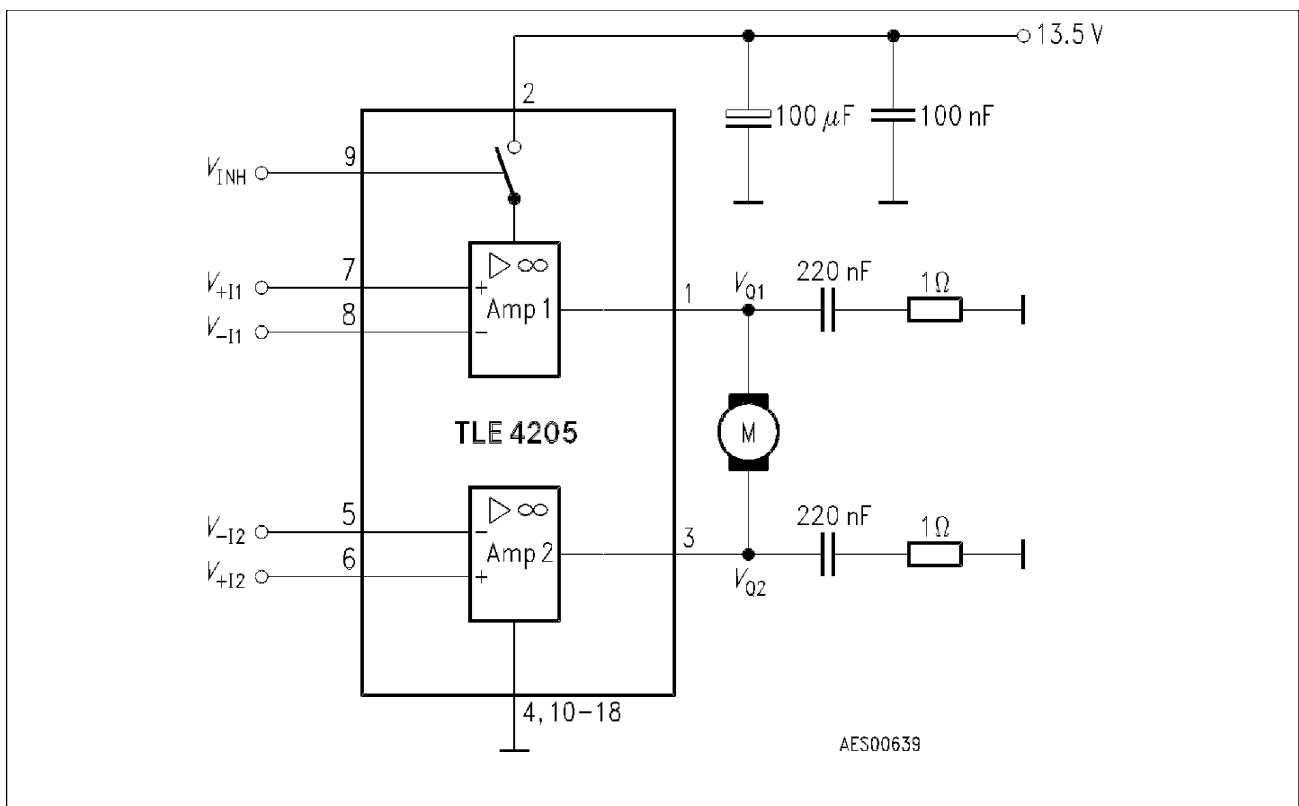

**Application Circuit**

**Forward Voltage of the Free-Wheeling Diodes versus Junction Temperature**

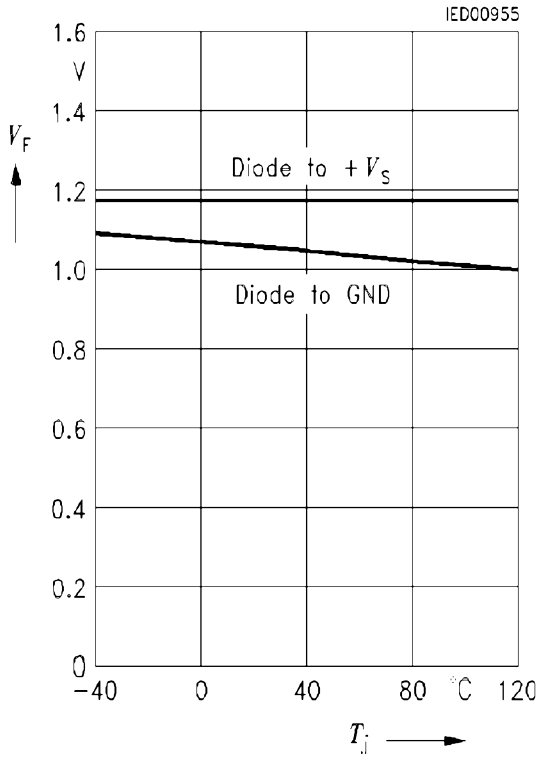

**Start Point of the SOA-Protection Circuit versus Junction Temperature**

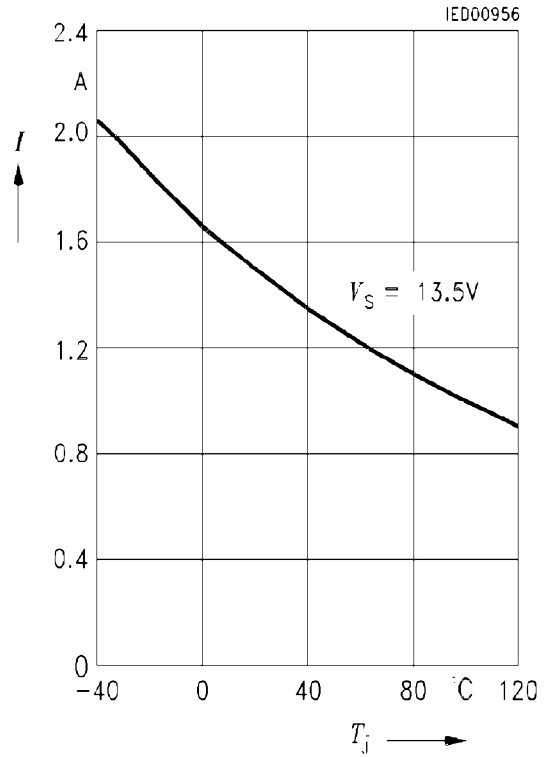

**Saturation Voltage versus Junction Temperature**

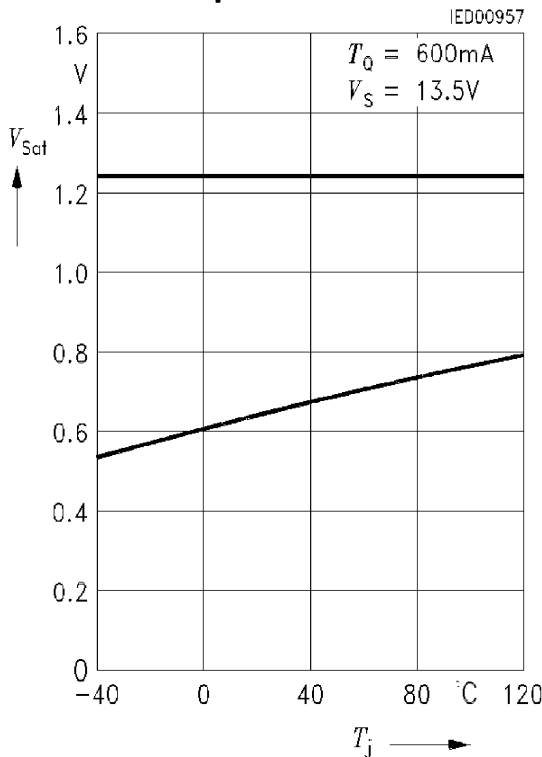

**Current Consumption versus Junction Temperature**

