

## Quad Supply Voltage Supervisor with Adjustable Delay and Watchdog Timer

Check for Samples: [TPS386000](#), [TPS386020](#), [TPS386040](#), [TPS386060](#)

### FEATURES

- Four Independent Voltage Supervisors
- Channels 1, 2, 3: Adjustable Threshold Down to 0.4V
- Channel 4: Adjustable Threshold at Any Positive/Negative Voltage
- Adjustable Delay Time: 1.4ms to 10s
- Threshold Accuracy: 0.25% typ
- Very Low Quiescent Current: 11µA typ
- Channel 1: Manual Reset (MR) Input
- Channel 4: Window Comparator
- Watchdog Timer with Dedicated Output
- Well-Controlled Output During Power-Up
- TPS386000: Open-Drain  $\overline{\text{RESET}}n$  and  $\overline{\text{WDO}}$
- TPS386020: Open-Drain  $\text{RESET}n$  and  $\text{WDO}$
- TPS386040: Push-Pull  $\overline{\text{RESET}}n$  and  $\overline{\text{WDO}}$
- TPS386060: Push-Pull  $\text{RESET}n$  and  $\text{WDO}$
- Package: 4mm x 4mm, 20-pin QFN

### APPLICATIONS

- All DSP and Microcontroller Applications
- All FPGA/ASIC Applications
- Telecom/Wireless Infrastructure
- Industrial Equipment
- Analog Sequencing

### DESCRIPTION

The TPS3860x0 family of supply voltage supervisors (SVSs) can monitor four power rails that are greater than 0.4V and one power rail less than 0.4V (including negative voltage) with a 0.25% (typical) threshold accuracy. Each of the four supervisory circuits (SVS- $n$ ) assert a  $\overline{\text{RESET}}n$  or  $\text{RESET}n$  output signal when the  $\text{SENSE}m$  input voltage drops below the programmed threshold. With external resistors, the threshold of each SVS- $n$  can be programmed (where  $n = 1, 2, 3, 4$  and  $m = 1, 2, 3, 4L, 4H$ ).

Each SVS- $n$  has a programmable delay before releasing  $\overline{\text{RESET}}n$  or  $\text{RESET}n$ . The delay time can be set independently for each SVS from 1.4ms to 10s through the  $\text{CT}n$  pin connection. Only SVS-1 has an active-low manual reset (MR) input; a logic-low input to MR asserts  $\overline{\text{RESET}}1$  or  $\text{RESET}1$ .

SVS-4 monitors the threshold window using two comparators. The extra comparator can be configured as a fifth SVS to monitor negative voltage with voltage reference output VREF.

The TPS3860x0 has a very low quiescent current of 11µA (typical) and is available in a small, 4mm x 4mm, QFN-20 package.

### TPS386000 Typical Application Circuit

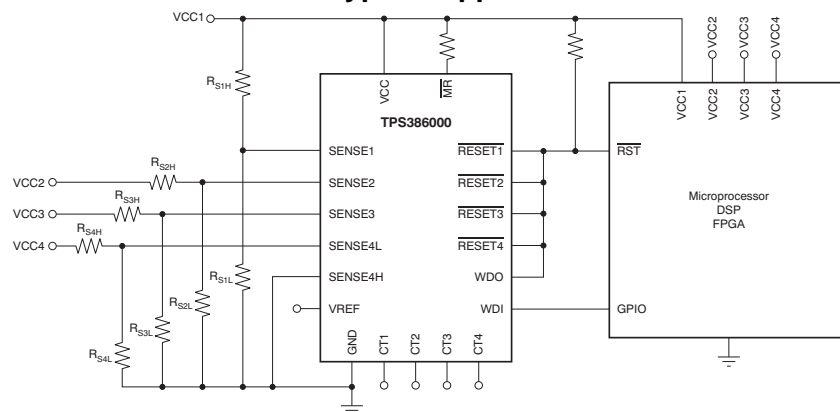

Please be aware that an important notice concerning availability, standard warranty, and use in critical applications of Texas Instruments semiconductor products and disclaimers thereto appears at the end of this data sheet.

All trademarks are the property of their respective owners.



This integrated circuit can be damaged by ESD. Texas Instruments recommends that all integrated circuits be handled with appropriate precautions. Failure to observe proper handling and installation procedures can cause damage.

ESD damage can range from subtle performance degradation to complete device failure. Precision integrated circuits may be more susceptible to damage because very small parametric changes could cause the device not to meet its published specifications.

### ORDERING INFORMATION<sup>(1)</sup>

PRODUCT	DESCRIPTION
TPS3860x0yyyz	<p><b>x</b> is device configuration option  <b>x</b> = 0: Open-drain, active low  <b>x</b> = 2: Open-drain, active high  <b>x</b> = 4: Push-pull, active low  <b>x</b> = 6: Push-pull, active high  <b>yyy</b> is package designator  <b>z</b> is package quantity</p>

(1) For the most current package and ordering information see the Package Option Addendum at the end of this document, or see the TI web site at [www.ti.com](http://www.ti.com).

### ABSOLUTE MAXIMUM RATINGS<sup>(1)</sup>

Over operating junction temperature range, unless otherwise noted.

	TPS3860x0	UNIT
Input voltage range, $V_{VCC}$	-0.3 to 7.0	V
CT pin voltage range, $V_{CT1}$ , $V_{CT2}$ , $V_{CT3}$ , $V_{CT4}$	-0.3 to $V_{VCC} + 0.3$	V
Other voltage ranges: $V_{RESET1}$ , $V_{RESET2}$ , $V_{RESET3}$ , $V_{RESET4}$ , $V_{MR}$ , $V_{SENSE1}$ , $V_{SENSE2}$ , $V_{SENSE3}$ , $V_{SENSE4L}$ , $V_{SENSE4H}$ , $V_{WDI}$ , $V_{WDO}$	-0.3 to 7.0	V
$\overline{RESETn}$ , $RESETn$ , $WDO$ , $WDO$ , $VREF$ pin current	5	mA
Continuous total power dissipation	See <a href="#">Dissipation Ratings Table</a>	
Operating virtual junction temperature range, $T_J$ <sup>(2)</sup>	-40 to +150	°C
Operating ambient temperature range	-40 to +125	°C
Storage temperature range, $T_{STG}$	-65 to +150	°C
ESD rating	Human body model (HBM)	2 kV
	Charged device model (CDM)	500 V

- (1) Stresses beyond those listed under the *Absolute Maximum Ratings* may cause permanent damage to the device. These are stress ratings only, and functional operation of the device at these or any other conditions beyond those indicated under the recommended operating conditions is not implied. Exposure to absolute maximum rated conditions for extended periods may affect device reliability.
- (2) As a result of the low dissipated power in this device, it is assumed that  $T_J = T_A$ .

### DISSIPATION RATINGS

PACKAGE	$T_A < +25^\circ\text{C}$ POWER RATING	DERATING FACTOR ABOVE $T_A > +25^\circ\text{C}$	$T_A = +70^\circ\text{C}$ POWER RATING	$T_A = +85^\circ\text{C}$ POWER RATING
RGP	2.86W	28.6mW/°C	1.57W	1.24W

## ELECTRICAL CHARACTERISTICS

Over the operating temperature range of  $T_J = -40^\circ\text{C}$  to  $+125^\circ\text{C}$ ,  $1.8\text{V} < V_{\text{VCC}} < 6.5\text{V}$ ,  $R_{\text{RESETn}} (n = 1, 2, 3, 4) = 100\text{k}\Omega$  to  $V_{\text{VCC}}$  (TPS386000, TPS386020 only),  $C_{\text{RESETn}} (n = 1, 2, 3, 4\text{L}, 4\text{H}) = 50\text{pF}$  to GND,  $R_{\text{WDO}} = 100\text{k}\Omega$  to  $V_{\text{VCC}}$ ,  $C_{\text{WDO}} = 50\text{pF}$  to GND,  $V_{\text{MR}} = 100\text{k}\Omega$  to  $V_{\text{VCC}}$ ,  $\text{WDI} = \text{GND}$ , and  $\text{CTn} (n = 1, 2, 3, 4) = \text{open}$ , unless otherwise noted. Typical values are at  $T_J = +25^\circ\text{C}$ .

PARAMETER		TEST CONDITIONS	MIN	TYP	MAX	UNIT		
$V_{\text{VCC}}$	Input supply range		1.8		6.5	V		
$I_{\text{VCC}}$	Supply current (current into VCC pin)	$V_{\text{VCC}} = 3.3\text{V}$ , $\overline{\text{RESETn}}$ or $\text{RESETn}$ not asserted, WDI toggling <sup>(1)</sup> , no output load, and VREF open		11	19	$\mu\text{A}$		
		$V_{\text{VCC}} = 6.5\text{V}$ , $\overline{\text{RESETn}}$ or $\text{RESETn}$ not asserted, WDI toggling <sup>(1)</sup> , no output load, and VREF open		13	22	$\mu\text{A}$		
	Power-up reset voltage <sup>(2)(3)</sup>	TPS386000, TPS386040	$V_{\text{OL}} (\text{max}) = 0.2\text{V}$ , $I_{\text{RESETn}} = 15\mu\text{A}$		0.9	V		
$V_{\text{ITN}}$	Negative-going input threshold voltage	SENSE1, SENSE2, SENSE3, SENSE4L	396	400	404	mV		
$V_{\text{ITP}}$	Positive-going input threshold voltage	SENSE4H	396	400	404	mV		
$V_{\text{HYSN}}$	Hysteresis (positive-going) on $V_{\text{ITN}}$	SENSE1, SENSE2, SENSE3, SENSE4L		3.5	10	mV		
$V_{\text{HYS P}}$	Hysteresis (negative-going) on $V_{\text{ITP}}$	SENSE4H		3.5	10	mV		
$I_{\text{SENSE}}$	Input current at SENSEm pin	$V_{\text{SENSEm}} = 0.42\text{V}$	-25	$\pm 1$	+25	nA		
$I_{\text{CT}}$	CTn pin charging current	CT1	$C_{\text{CT1}} > 220\text{pF}$ , $V_{\text{CT1}} = 0.5\text{V}^{(4)}$		245	300	355	nA
		CT2, CT3, CT4	$C_{\text{CTn}} > 220\text{pF}$ , $V_{\text{CTn}} = 0.5\text{V}^{(4)}$		235	300	365	nA
$V_{\text{TH(CTn)}}$	CTn pin threshold	$C_{\text{CTn}} > 220\text{pF}$	1.180	1.238	1.299	V		
$V_{\text{IL}}$	$\overline{\text{MR}}$ and WDI logic low input		0		$0.3V_{\text{VCC}}$	V		
$V_{\text{IH}}$	$\overline{\text{MR}}$ and WDI logic high input		$0.7V_{\text{VCC}}$			V		
$V_{\text{OL}}$	Low-level $\overline{\text{RESETn}}$ or $\text{RESETn}$ output voltage	All	$I_{\text{OL}} = 1\text{mA}$			0.4	V	
		TPS386000, TPS386040	$\text{SENSEn} = 0\text{V}$ , $1.3\text{V} < V_{\text{VCC}} < 1.8\text{V}$ , $I_{\text{OL}} = 0.4\text{mA}^{(2)}$			0.3	V	
	Low-level WDO output voltage	All	$I_{\text{OL}} = 1\text{mA}$			0.4	V	
		TPS386020, TPS386060	$\text{SENSEn} = 0\text{V}$ , $1.3\text{V} < V_{\text{VCC}} < 1.8\text{V}$ , $I_{\text{OL}} = 0.4\text{mA}^{(2)}$			0.3	V	
$V_{\text{OH}}$	High-level $\overline{\text{RESETn}}$ or $\text{RESETn}$ output voltage	TPS386040, TPS386060	$I_{\text{OL}} = -1\text{mA}$		$V_{\text{VCC}} - 0.4$		V	
		TPS386060	$\text{SENSEn} = 0\text{V}$ , $1.3\text{V} < V_{\text{VCC}} < 1.8\text{V}$ , $I_{\text{OL}} = -0.4\text{mA}^{(2)}$		$V_{\text{VCC}} - 0.3$		V	
	High-level WDO output voltage	TPS386040, TPS386060	$I_{\text{OL}} = -1\text{mA}$		$V_{\text{VCC}} - 0.4$		V	
		TPS386040	$\text{SENSEn} = 0\text{V}$ , $1.3\text{V} < V_{\text{VCC}} < 1.8\text{V}$ , $I_{\text{OL}} = -0.4\text{mA}^{(2)}$		$V_{\text{VCC}} - 0.3$		V	
$I_{\text{LKG}}$	$\overline{\text{RESETn}}$ , $\text{RESETn}$ , WDO, and WDO leakage current	TPS386000, TPS386020	$V_{\text{RESETn}} = 6.5\text{V}$ , $\overline{\text{RESETn}}$ , $\text{RESETn}$ , $\overline{\text{WDO}}$ , and WDO are logic high		-300	300	nA	
$V_{\text{REF}}$	Reference voltage output		$1\mu\text{A} < I_{\text{VREF}} < 0.2\text{mA}$ (source only, no sink)		1.18	1.20	1.22	V
$C_{\text{IN}}$	Input pin capacitance	CTn: 0V to $V_{\text{VCC}}$ , other pins: 0V to 6.5V		5		pF		
$t_{\text{W}}$	Input pulse width to SENSEm and $\overline{\text{MR}}$ pins	SENSEm: $1.05V_{\text{ITN}} \rightarrow 0.95V_{\text{ITN}}$ or $0.95V_{\text{ITP}} \rightarrow 1.05V_{\text{ITP}}$		4		$\mu\text{s}$		
		$\overline{\text{MR}}$ : $0.7V_{\text{VCC}} \rightarrow 0.3V_{\text{VCC}}$		1		ns		
$t_{\text{D}}$	$\overline{\text{RESETn}}$ or $\text{RESETn}$ delay time	CTn = open	14	20	24	ms		
		CTn = $V_{\text{VCC}}$	225	300	375	ms		
$t_{\text{WDT}}$	Watchdog timer timeout period	Start from $\overline{\text{RESET1}}$ or $\text{RESET1}$ release or last WDI transition	450	600	750	ms		

- (1) Toggling WDI for a period less than  $t_{\text{WDT}}$  negatively affects  $I_{\text{VCC}}$ .
- (2) These specifications are beyond the recommended  $V_{\text{VCC}}$  range, and only define  $\overline{\text{RESETn}}$  or  $\text{RESETn}$  output performance during VCC ramp up.
- (3) The lowest supply voltage ( $V_{\text{VCC}}$ ) at which  $\overline{\text{RESETn}}$  or  $\text{RESETn}$  becomes active;  $t_{\text{RISE}}(V_{\text{CC}}) \geq 15\mu\text{s/V}$ .
- (4) CTn (where  $n = 1, 2, 3$ , or 4) are constant current charging sources working from a range of 0V to  $V_{\text{TH(CTn)}}$ , and the device is tested at  $V_{\text{CTn}} = 0.5\text{V}$ . For  $I_{\text{CT}}$  performance between 0V and  $V_{\text{TH(CTn)}}$ , see Figure 25.

## PIN CONFIGURATIONS

### RGP PACKAGE QFN-20 (TOP VIEW)

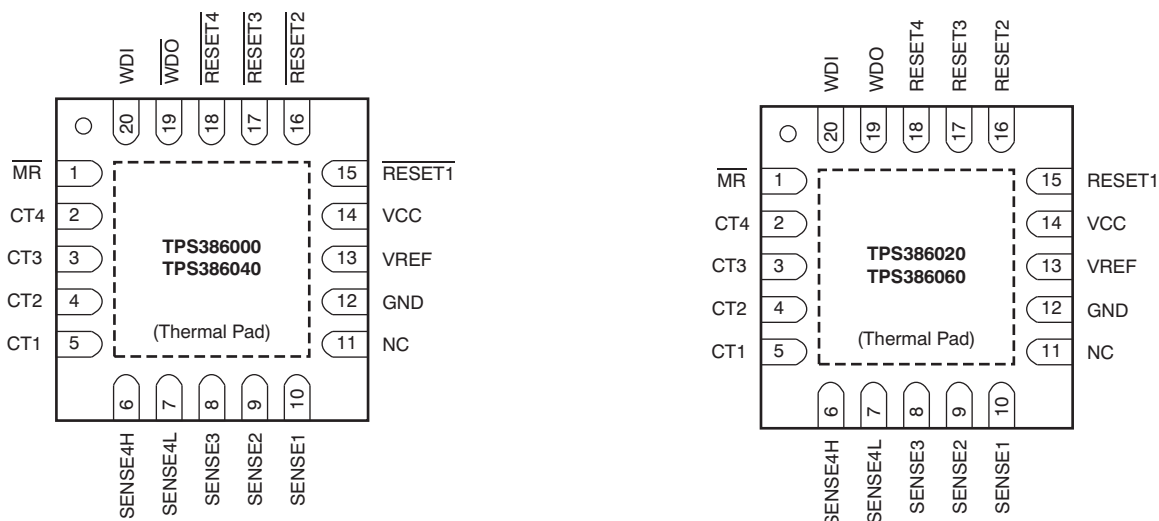

### PIN ASSIGNMENTS

PIN		DESCRIPTION
NAME	NO.	
VCC	14	Supply voltage. Connecting a 0.1µF ceramic capacitor close to this pin is recommended.
GND	12	Ground
SENSE1	10	Monitor voltage input to SVS-1
SENSE2	9	Monitor voltage input to SVS-2
SENSE3	8	Monitor voltage input to SVS-3
SENSE4L	7	Falling monitor voltage input to SVS-4. When the voltage at this terminal drops below the threshold voltage ( $V_{ITN}$ ), RESET4 or RESET4 is asserted.
SENSE4H	6	Rising monitor voltage input to SVS-4. When the voltage at this terminal exceeds the threshold voltage ( $V_{ITP}$ ), RESET4 or RESET4 is asserted. This pin can also be used to monitor the negative voltage rail in combination with VREF pin. Connect to GND if not being used.
CT1	5	Reset delay programming pin for SVS-1
CT2	4	Reset delay programming pin for SVS-2
CT3	3	Reset delay programming pin for SVS-3
CT4	2	Reset delay programming pin for SVS-4
VREF	13	Reference voltage output. By connecting a resistor network between this pin and the negative power rail, SENSE4H can monitor the negative power rail. This pin is intended to only source current into resistor(s). Do not connect resistor(s) to a voltage higher than 1.2V. Do not connect only a capacitor.
MR	1	Manual reset input for SVS-1. Logic low level of this pin asserts RESET1 or RESET1.
WDI	20	Watchdog timer (WDT) trigger input. Inputting either a positive or negative logic edge every 610ms (typ) prevents WDT time out at the WDO or WDO pin. Timer starts from releasing event of RESET1 or RESET1.
NC	11	Not connected. It is recommended to connect this pin to the GND pin (pin 12), which is next to this pin.
(Thermal Pad)	(PAD)	This is the IC substrate. This pad must be connected only to GND or to the floating thermal pattern on the printed circuit board (PCB).

**PIN ASSIGNMENTS (continued)**

PIN		DESCRIPTION
NAME	NO.	
<b>TPS386000</b>		
$\overline{\text{RESET}}1$	15	Active low reset output of SVS-1
$\overline{\text{RESET}}2$	16	Active low reset output of SVS-2
$\overline{\text{RESET}}3$	17	Active low reset output of SVS-3
$\overline{\text{RESET}}4$	18	Active low reset output of SVS-4
$\overline{\text{WDO}}$	19	Watchdog timer output. This is an open-drain output pin. When WDT times out, this pin goes to a low-impedance state to GND. If there is no WDT timeout, this pin stays in a high-impedance state.
<b>TPS386020</b>		
RESET1	15	Active high reset output of SVS-1
RESET2	16	Active high reset output of SVS-2
RESET3	17	Active high reset output of SVS-3
RESET4	18	Active high reset output of SVS-4
WDO	19	Watchdog timer output. This is an open-drain output pin. When WDT times out, this pin goes to a high-impedance state. If there is no WDT timeout, this pin stays in a low-impedance state to GND.
<b>TPS386040</b>		
$\overline{\text{RESET}}1$	15	Active low reset output of SVS-1
$\overline{\text{RESET}}2$	16	Active low reset output of SVS-2
$\overline{\text{RESET}}3$	17	Active low reset output of SVS-3
$\overline{\text{RESET}}4$	18	Active low reset output of SVS-4
$\overline{\text{WDO}}$	19	Watchdog timer output. This is a push-pull output pin. When WDT times out, this pin goes to logic low. If there is no WDT timeout, this pin stays in logic high.
<b>TPS386060</b>		
RESET1	15	Active high reset output of SVS-1
RESET2	16	Active high reset output of SVS-2
RESET3	17	Active high reset output of SVS-3
RESET4	18	Active high reset output of SVS-4
WDO	19	Watchdog timer output. This is a push-pull output pin. When WDT times out, this pin goes to logic high. If there is no WDT timeout, this pin stays in logic low.

**FUNCTIONAL BLOCK DIAGRAMS**

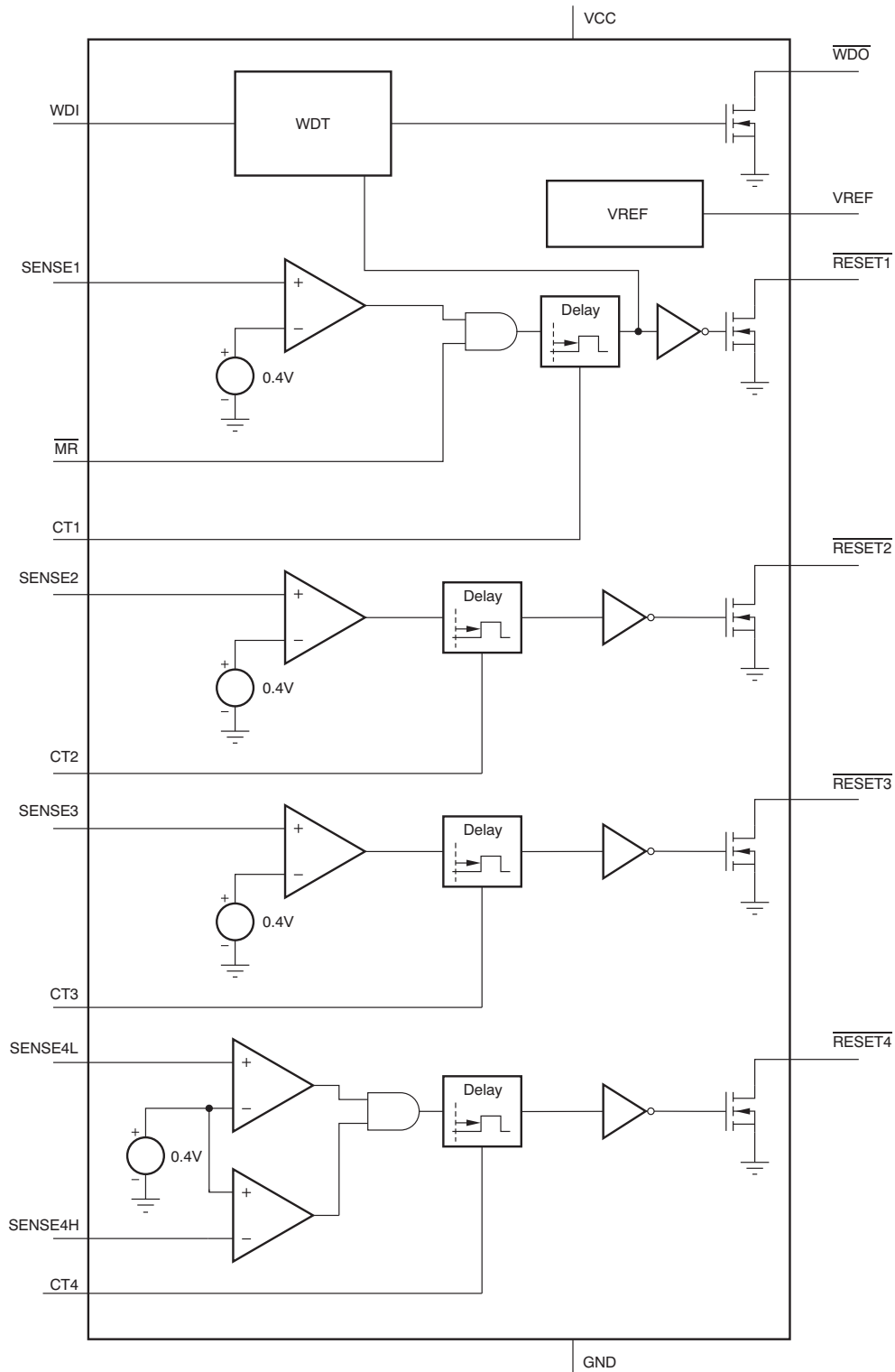

**Figure 1. TPS386000 Block Diagram**

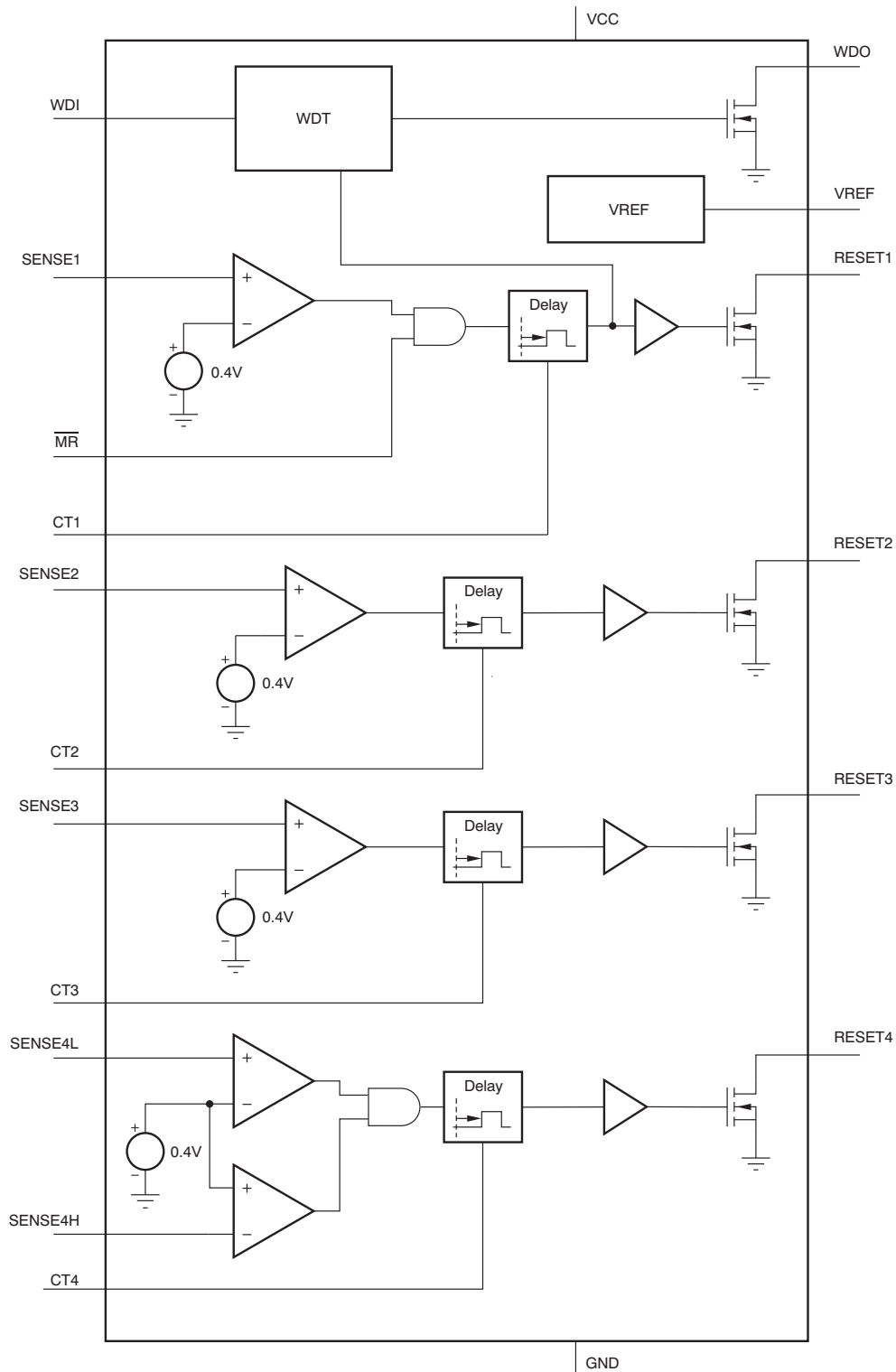

Figure 2. TPS386020 Block Diagram

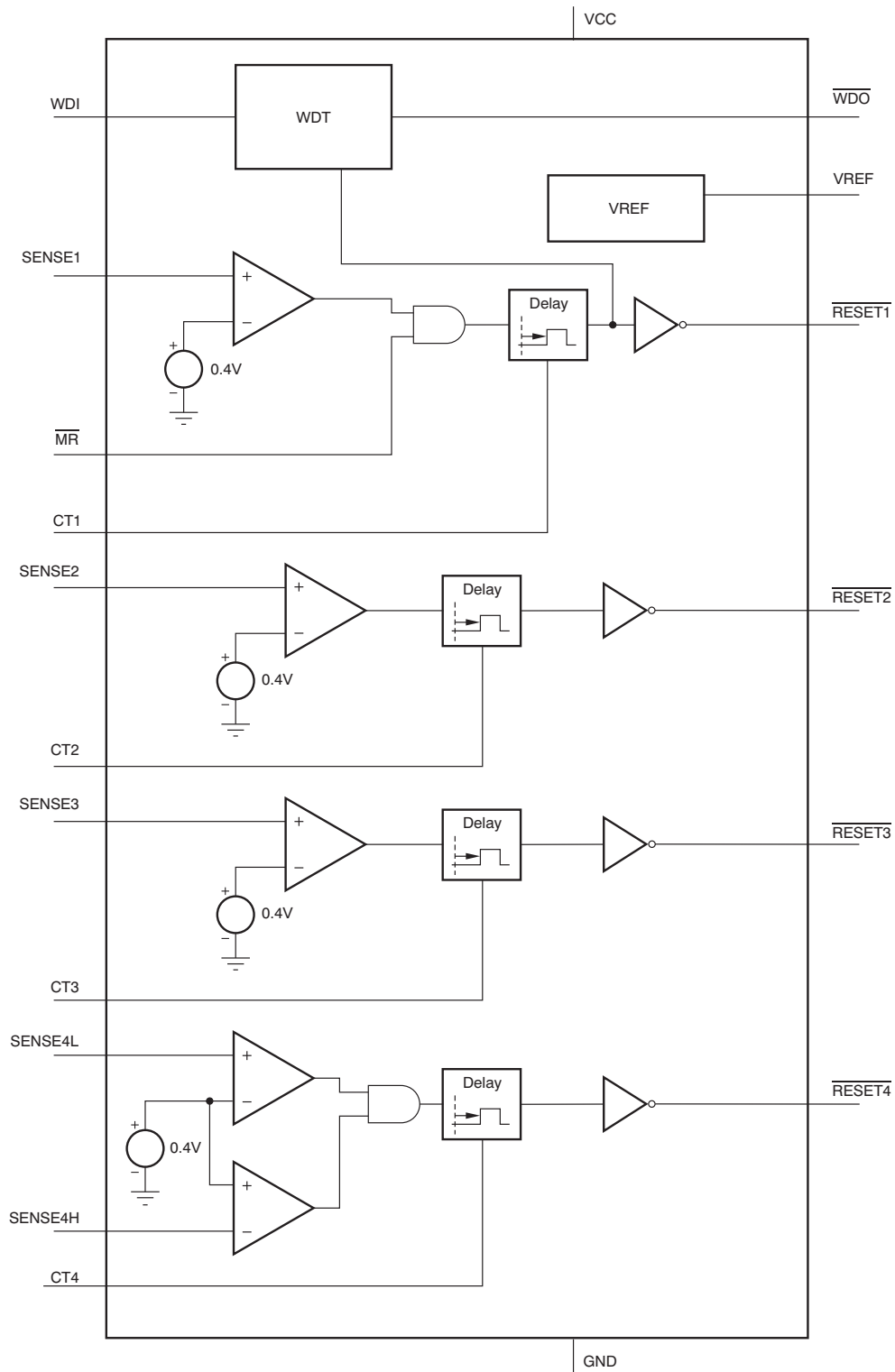

Figure 3. TPS386040 Block Diagram



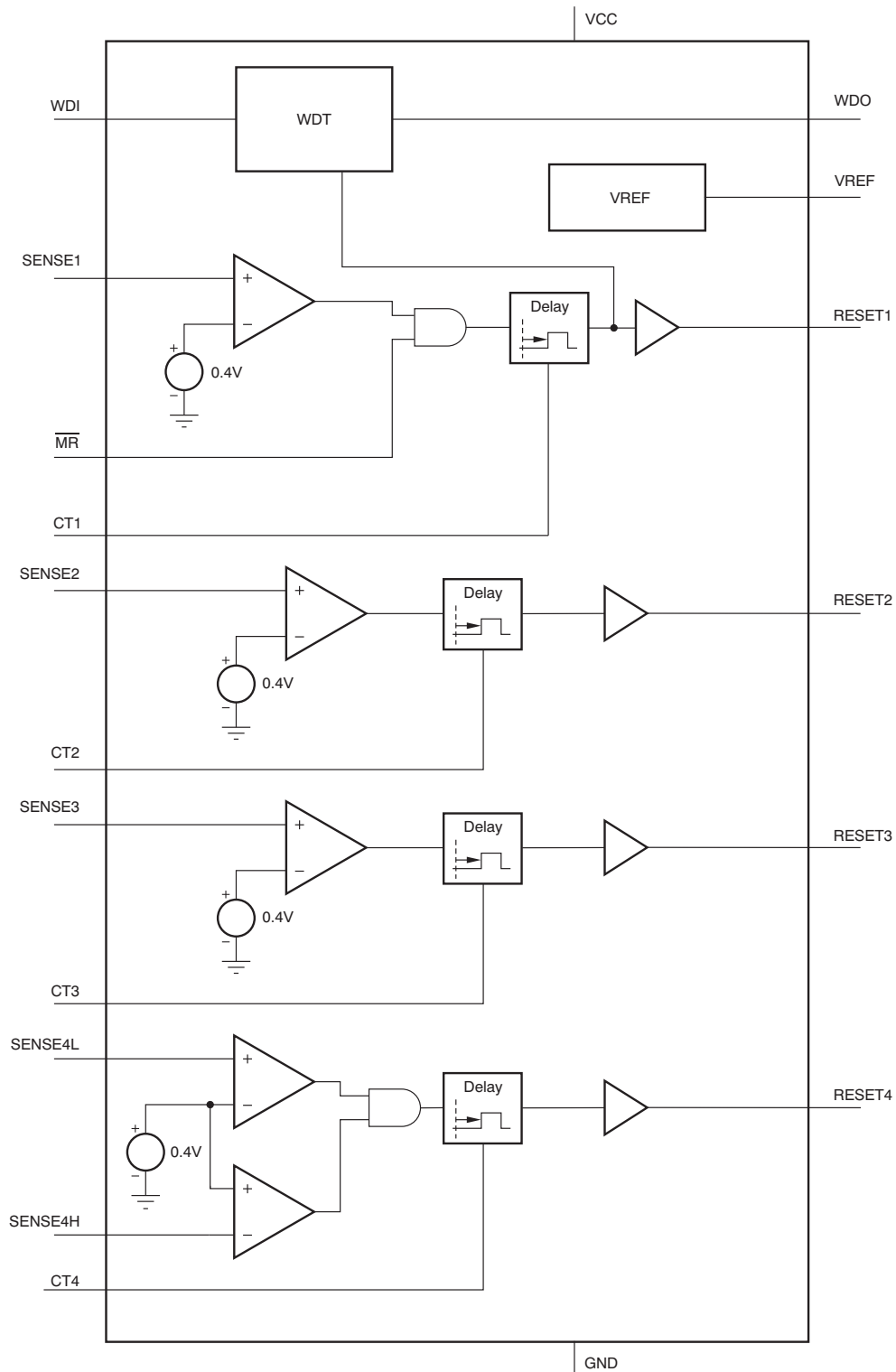

Figure 4. TPS386060 Block Diagram

### TYPICAL CHARACTERISTICS

At  $T_A = +25^\circ\text{C}$ , and  $V_{CC} = 3.3\text{V}$ , with all four options (TPS386000, TPS386020, TPS386040, and TPS386060) having the same characteristics, unless otherwise noted.

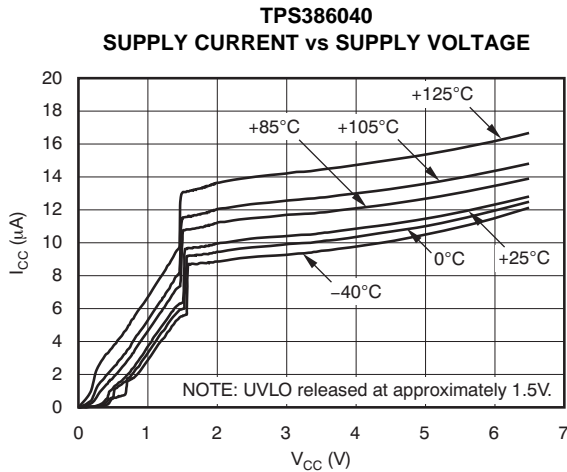

Figure 5.

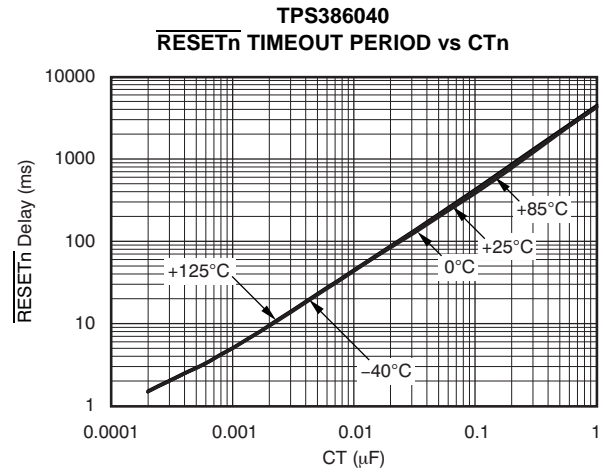

Figure 6.

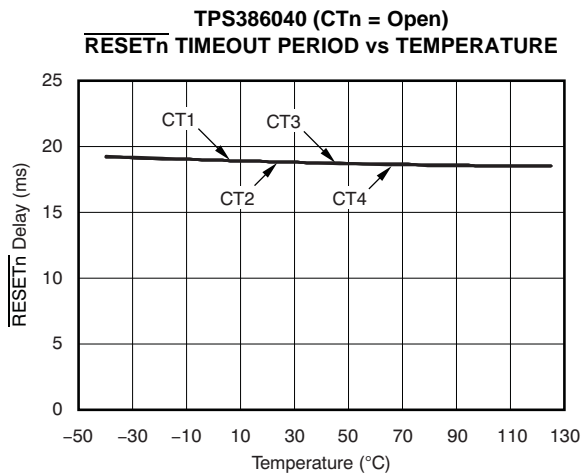

Figure 7.

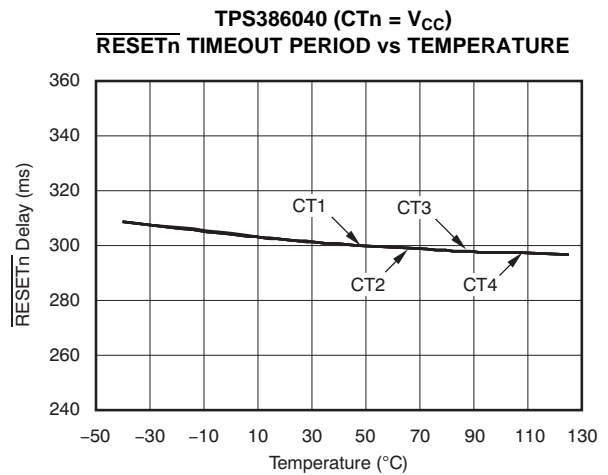

Figure 8.

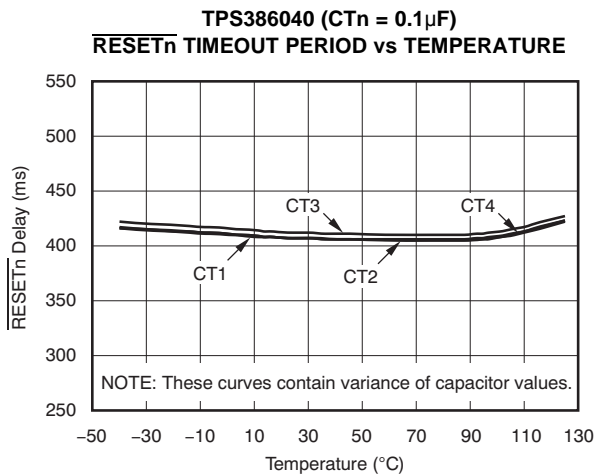

Figure 9.

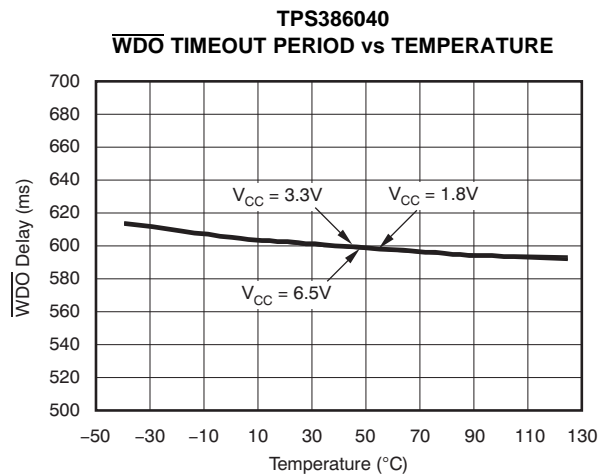

Figure 10.

**TYPICAL CHARACTERISTICS (continued)**

At  $T_A = +25^\circ\text{C}$ , and  $V_{CC} = 3.3\text{V}$ , with all four options (TPS386000, TPS386020, TPS386040, and TPS386060) having the same characteristics, unless otherwise noted.

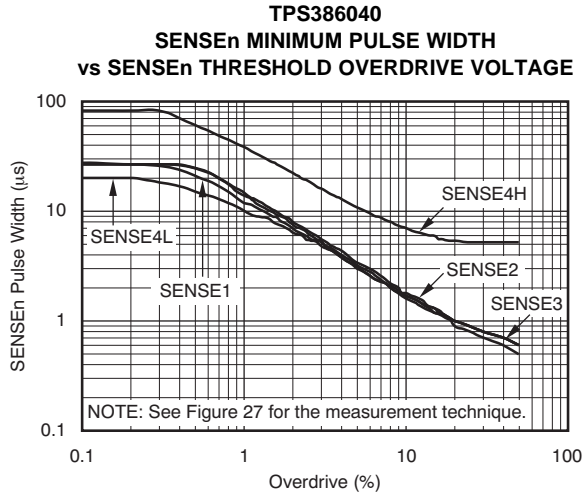

Figure 11.

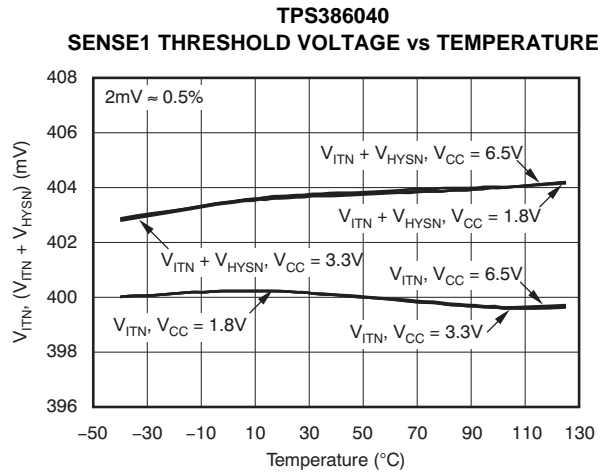

Figure 12.

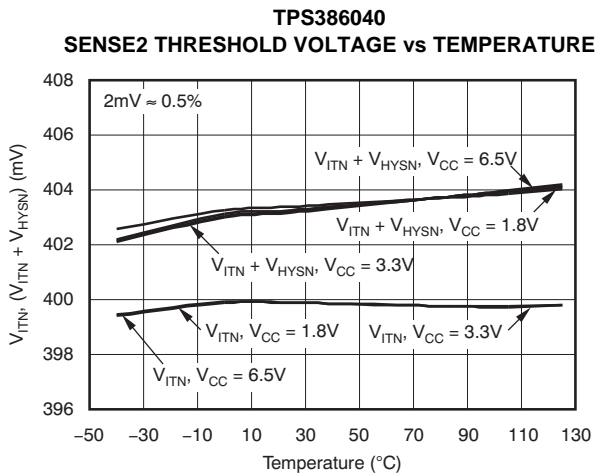

Figure 13.

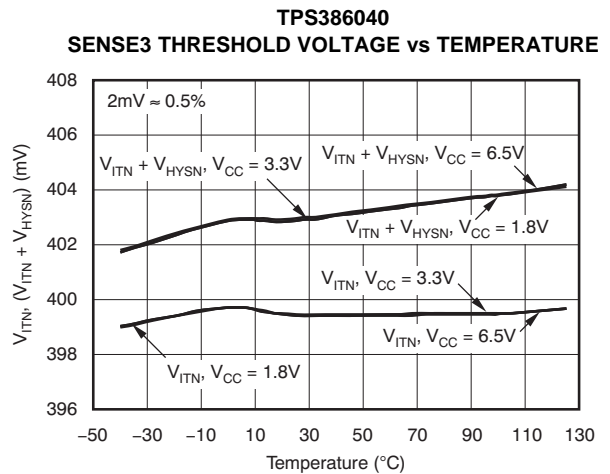

Figure 14.

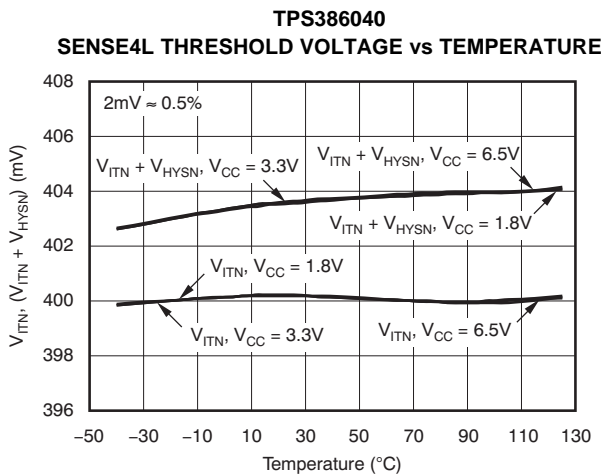

Figure 15.

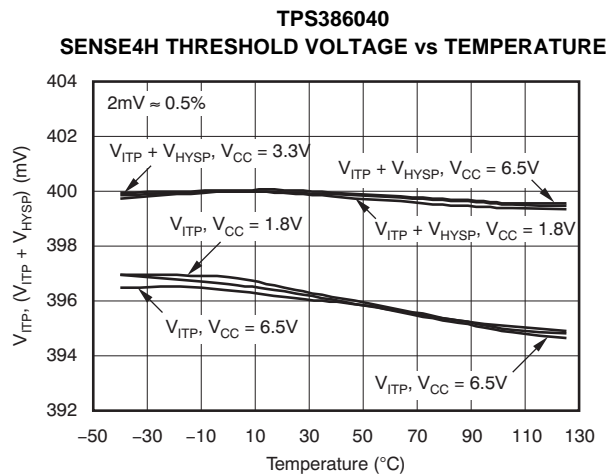

Figure 16.

**TYPICAL CHARACTERISTICS (continued)**

At  $T_A = +25^\circ\text{C}$ , and  $V_{CC} = 3.3\text{V}$ , with all four options (TPS386000, TPS386020, TPS386040, and TPS386060) having the same characteristics, unless otherwise noted.

**OUTPUT VOLTAGE LOW vs OUTPUT CURRENT**

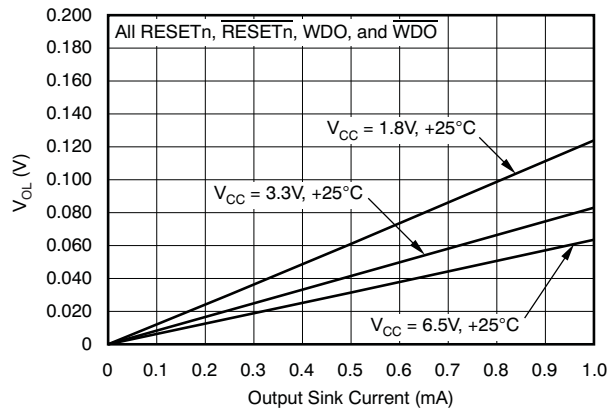

Figure 17.

**OUTPUT VOLTAGE LOW AT 1mA vs TEMPERATURE**

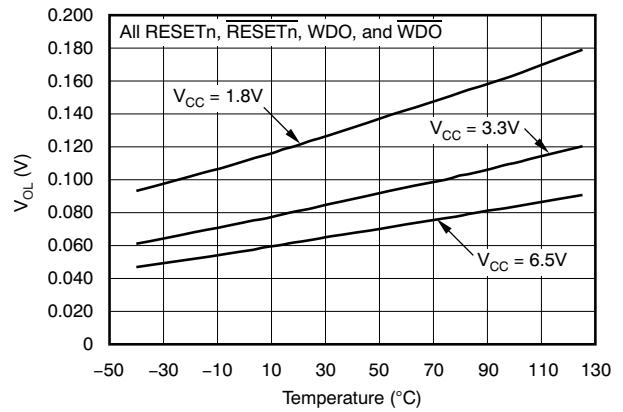

Figure 18.

**OUTPUT VOLTAGE HIGH vs OUTPUT CURRENT**

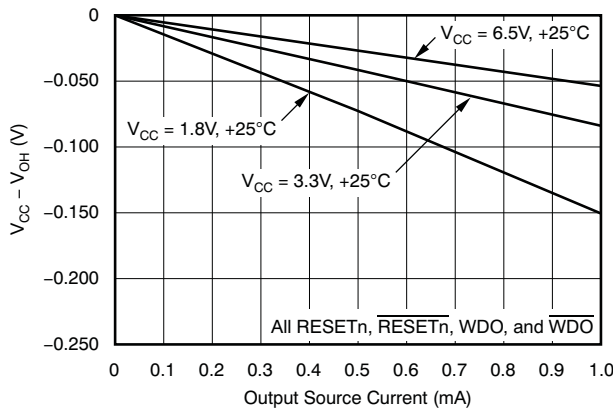

Figure 19.

**OUTPUT VOLTAGE HIGH AT 1mA vs TEMPERATURE**

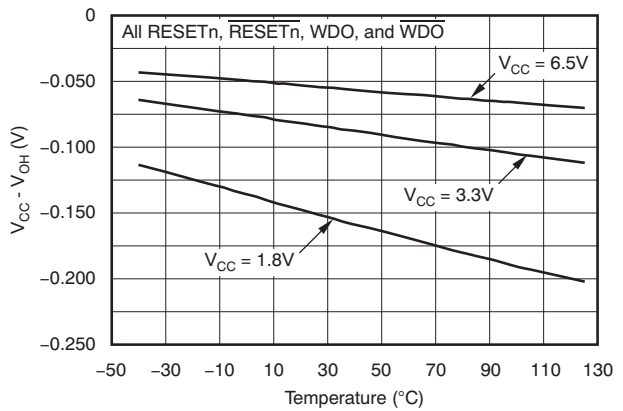

Figure 20.

**TPS386040**

**V\_REF OUTPUT LOAD REGULATION ( $V_{CC} = 1.8\text{V}$ )**

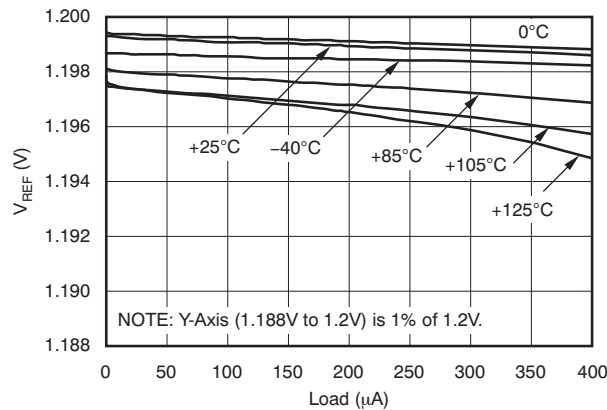

Figure 21.

**TPS386040**

**V\_REF OUTPUT LOAD REGULATION ( $V_{CC} = 3.3\text{V}$ )**

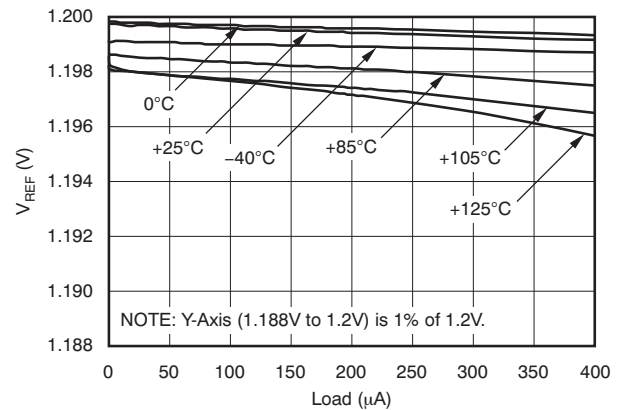

Figure 22.

**TYPICAL CHARACTERISTICS (continued)**

At  $T_A = +25^\circ\text{C}$ , and  $V_{CC} = 3.3\text{V}$ , with all four options (TPS386000, TPS386020, TPS386040, and TPS386060) having the same characteristics, unless otherwise noted.

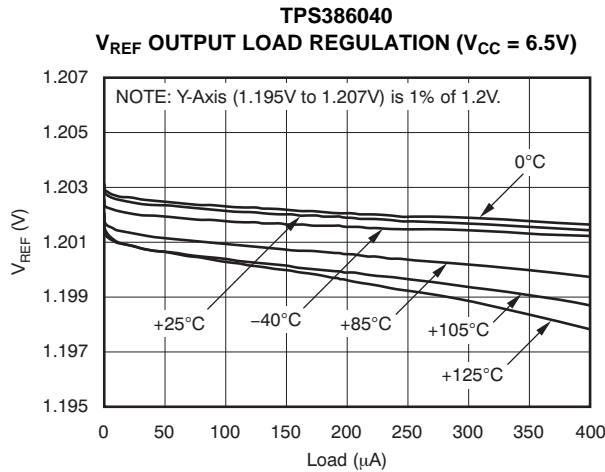

Figure 23.

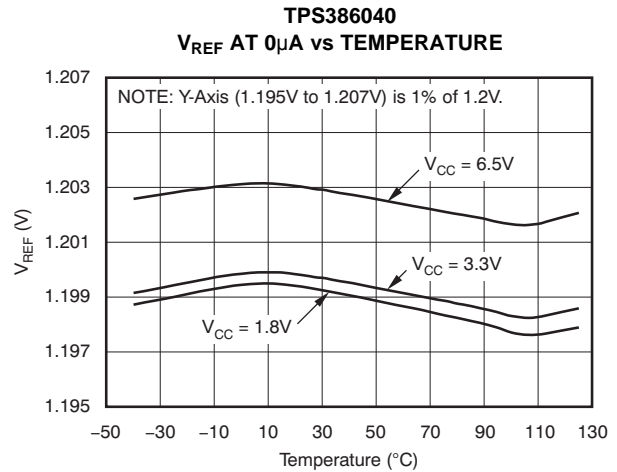

Figure 24.

**TPS386040 CT1 TO CT4 PIN CHARGING CURRENT vs TEMPERATURE OVER CT PIN VOLTAGE**

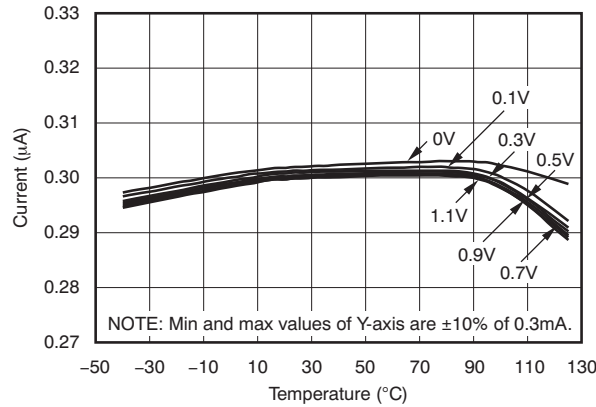
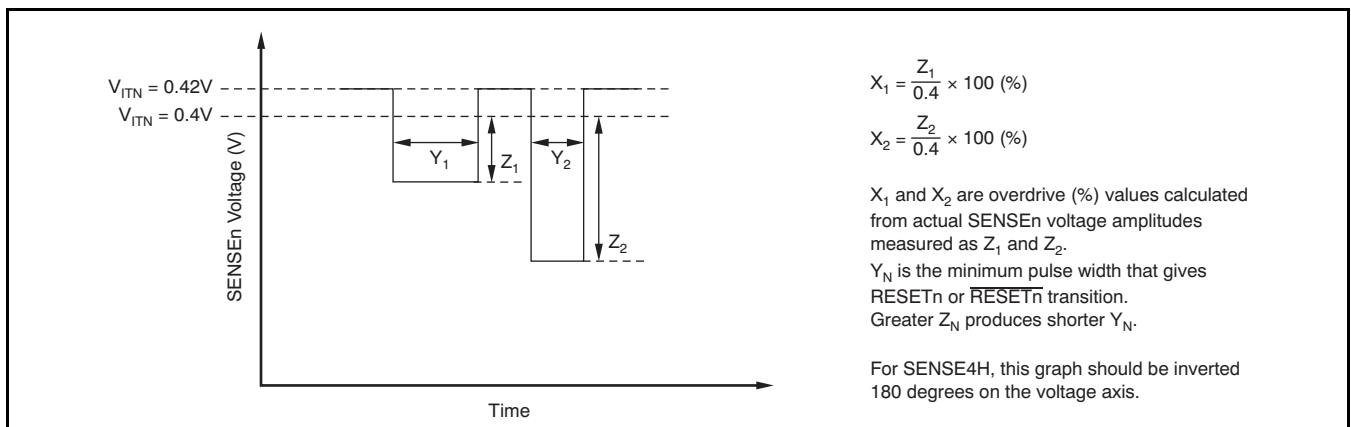

Figure 25.

**PARAMETRIC MEASUREMENT INFORMATION**

**TEST CIRCUIT**



## GENERAL DESCRIPTION

The TPS3860x0 multi-channel supervisory device family combines four complete SVS function sets into one IC, along with a watchdog timer, a window comparator, and negative voltage sensing. The design of each SVS channel is based on the single-channel supervisory device series, [TPS3808](#). The TPS3860x0 is designed to assert  $\overline{\text{RESETn}}$  or  $\text{RESETn}$  signals, as shown in [Table 1](#), [Table 2](#), [Table 3](#), and [Table 4](#). The  $\overline{\text{RESETn}}$  or  $\text{RESETn}$  outputs remain asserted during a

user-configurable delay time after the event of reset release (see the [Reset Delay Time](#) section). Each  $\text{SENSEm}$  ( $m = 1, 2, 3, 4L$ ) pin can be set to any voltage threshold above 0.4V using an external resistor divider. The  $\text{SENSE4H}$  pin can be used for any overvoltage detection greater than 0.4V, or for negative voltage detection using an external resistor divider (see the [Sensing Voltage Less Than 0.4V](#) section). A broad range of voltage threshold and reset delay time adjustments can be supported, allowing these devices to be used in a wide array of applications.

**Table 1. SVS-1 Truth Table**

CONDITION		OUTPUT		STATUS
		TPS386000 TPS386040	TPS386020 TPS386060	
$\overline{\text{MR}} = \text{Low}$	$\text{SENSE1} < V_{\text{ITN}}$	$\overline{\text{RESET1}} = \text{Low}$	$\text{RESET1} = \text{High}$	Reset asserted
$\overline{\text{MR}} = \text{Low}$	$\text{SENSE1} > V_{\text{ITN}}$	$\overline{\text{RESET1}} = \text{Low}$	$\text{RESET1} = \text{High}$	Reset asserted
$\overline{\text{MR}} = \text{High}$	$\text{SENSE1} < V_{\text{ITN}}$	$\overline{\text{RESET1}} = \text{Low}$	$\text{RESET1} = \text{High}$	Reset asserted
$\overline{\text{MR}} = \text{High}$	$\text{SENSE1} > V_{\text{ITN}}$	$\overline{\text{RESET1}} = \text{High}$	$\text{RESET1} = \text{Low}$	<b>Reset released after delay</b>

**Table 2. SVS-2 Truth Table**

CONDITION	OUTPUT		STATUS
	TPS386000 TPS386040	TPS386020 TPS386060	
$\text{SENSE2} < V_{\text{ITN}}$	$\overline{\text{RESET2}} = \text{Low}$	$\text{RESET2} = \text{High}$	Reset asserted
$\text{SENSE2} > V_{\text{ITN}}$	$\overline{\text{RESET2}} = \text{High}$	$\text{RESET2} = \text{Low}$	<b>Reset released after delay</b>

**Table 3. SVS-3 Truth Table**

CONDITION		OUTPUT		STATUS
		TPS386000 TPS386040	TPS386020 TPS386060	
$\text{SENSE3} < V_{\text{ITN}}$		$\overline{\text{RESET3}} = \text{Low}$	$\text{RESET3} = \text{High}$	Reset asserted
$\text{SENSE3} > V_{\text{ITN}}$		$\overline{\text{RESET3}} = \text{High}$	$\text{RESET3} = \text{Low}$	<b>Reset released after delay</b>

**Table 4. SVS-4 Truth Table**

CONDITION		OUTPUT		STATUS
		TPS386000 TPS386040	TPS386020 TPS386060	
$\text{SENSE4L} < V_{\text{ITN}}$	$\text{SENSE4H} > V_{\text{ITP}}$	$\overline{\text{RESET4}} = \text{Low}$	$\text{RESET4} = \text{High}$	Reset asserted
$\text{SENSE4L} < V_{\text{ITN}}$	$\text{SENSE4H} < V_{\text{ITP}}$	$\overline{\text{RESET4}} = \text{Low}$	$\text{RESET4} = \text{High}$	Reset asserted
$\text{SENSE4L} > V_{\text{ITN}}$	$\text{SENSE4H} > V_{\text{ITP}}$	$\overline{\text{RESET4}} = \text{Low}$	$\text{RESET4} = \text{High}$	Reset asserted
$\text{SENSE4L} > V_{\text{ITN}}$	$\text{SENSE4H} < V_{\text{ITP}}$	$\overline{\text{RESET4}} = \text{High}$	$\text{RESET4} = \text{Low}$	<b>Reset released after delay</b>

**Table 5. Watchdog Timer (WDT) Truth Table**

CONDITION				OUTPUT		STATUS
$\overline{\text{WDO}}$	WDO	$\overline{\text{RESET1}}$ OR RESET1	WDI PULSE INPUT	TPS386000 TPS386040	TPS386020 TPS386060	
Low	High	Asserted	Toggling	$\overline{\text{WDO}} = \text{low}$	WDO = high	Remains in WDT timeout
Low	High	Asserted	610ms after last WDI $\uparrow$ or WDI $\downarrow$	$\overline{\text{WDO}} = \text{low}$	WDO = high	Remains in WDT timeout
Low	High	Released	Toggling	$\overline{\text{WDO}} = \text{low}$	WDO = high	Remains in WDT timeout
Low	High	Released	610ms after last WDI $\uparrow$ or WDI $\downarrow$	$\overline{\text{WDO}} = \text{low}$	WDO = high	Remains in WDT timeout
High	Low	Asserted	Toggling	$\overline{\text{WDO}} = \text{high}$	WDO = low	Normal operation
High	Low	Asserted	610ms after last WDI $\uparrow$ or WDI $\downarrow$	$\overline{\text{WDO}} = \text{high}$	WDO = low	Normal operation
High	Low	Released	Toggling	$\overline{\text{WDO}} = \text{high}$	WDO = low	Normal operation
High	Low	Released	610ms after last WDI $\uparrow$ or WDI $\downarrow$	$\overline{\text{WDO}} = \text{low}$	WDO = high	Enters WDT timeout

## RESET OUTPUT

In a typical TPS3860x0 application,  $\overline{\text{RESETn}}$  or RESETn outputs are connected to the reset input of a processor (DSP, CPU, FPGA, ASIC, etc.), or connected to the enable input of a voltage regulator (DC-DC, LDO, etc.)

The TPS386000 and TPS386020 provide open-drain reset outputs. Pull-up resistors must be used to hold these lines high when  $\overline{\text{RESETn}}$  is not asserted, or when RESETn is asserted. By connecting pull-up resistors to the proper voltage rails (up to 6.5V),  $\overline{\text{RESETn}}$  or RESETn output nodes can be connected to the other devices at the correct interface voltage levels. The pull-up resistor should be no smaller than 10k $\Omega$  because of the safe operation of the output transistors. By using wired-OR logic, any combination of  $\overline{\text{RESETn}}$  can be merged into one logic signal.

The TPS386040 and TPS386060 provide push-pull reset outputs. The logic high level of the outputs is determined by the VCC voltage. With this configuration, pull-up resistors are not required and some board area can be saved. However, all the interface logic levels should be examined. All  $\overline{\text{RESETn}}$  or RESETn connections must be compatible with the VCC logic level.

The  $\overline{\text{RESETn}}$  or RESETn outputs are defined for VCC voltage higher than 0.9V. To ensure that the target processor(s) are properly reset, the VCC supply input should be fed by the available power rail as early as possible in application circuits. Table 1, Table 2, Table 3, and Table 4 are truth tables that describe how the outputs are asserted or released. Figure 26, Figure 27, Figure 28, and Figure 29 show the SVS-n timing diagrams. When the condition(s) are met, the device changes the state of SVS-n from asserted to released after a user-configurable delay time. However, the transitions from released-state to asserted-state are performed almost immediately with minimal propagation delay. Figure 28 describes relationship between threshold voltages ( $V_{\text{ITN}}$  and  $V_{\text{HYSN}}$ ) and SENSEm voltage; and all SVS-1, SVS-2, SVS-3, and SVS-4 have the same behavior of Figure 28.

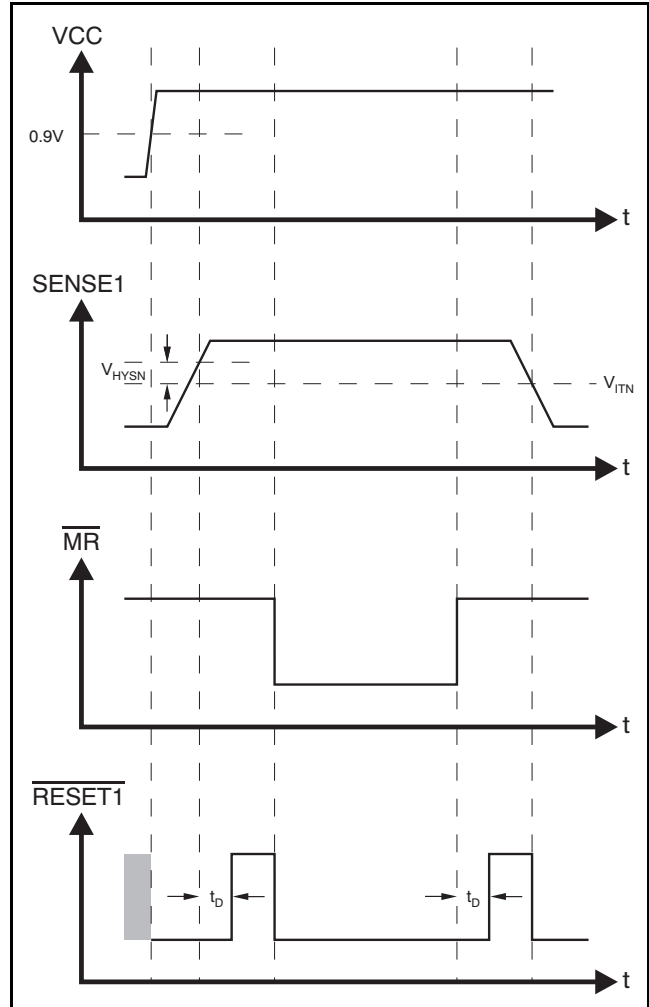

NOTE: The TPS386000 or TPS386040 is shown here using  $\overline{\text{RESETn}}$ . The TPS386020 and TPS386060 use RESETn; therefore, the diagram of  $\overline{\text{RESETn}}$  should be read as RESETn with the opposite polarity.

Figure 26. SVS-1 Timing Diagram



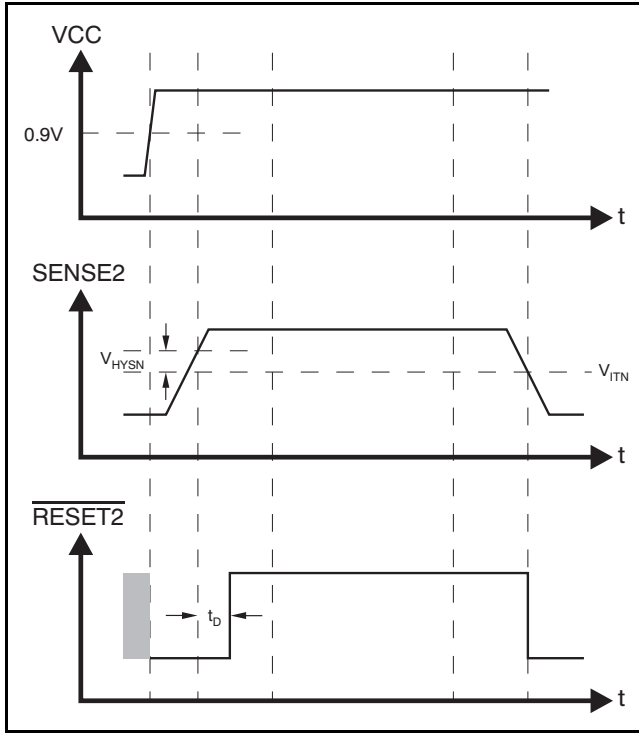

NOTE: The TPS386000 or TPS386040 is shown here using  $\overline{\text{RESETn}}$ . The TPS386020 and TPS386060 use  $\text{RESETn}$ ; therefore, the diagram of  $\overline{\text{RESETn}}$  should be read as  $\text{RESETn}$  with the opposite polarity.

Figure 27. SVS-2 Timing Diagram

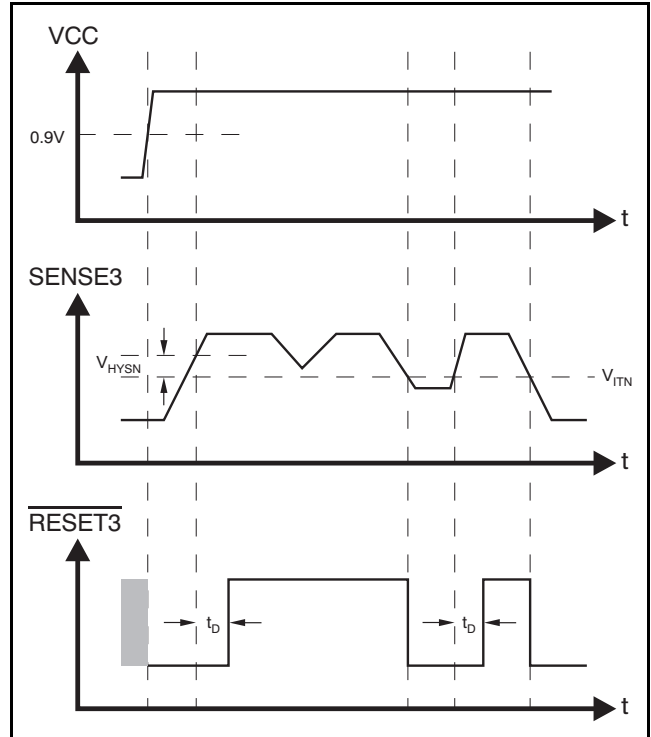

NOTE: The TPS386000 or TPS386040 is shown here using  $\overline{\text{RESETn}}$ . The TPS386020 and TPS386060 use  $\text{RESETn}$ ; therefore, the diagram of  $\overline{\text{RESETn}}$  should be read as  $\text{RESETn}$  with the opposite polarity.

Figure 28. SVS-3 Timing Diagram

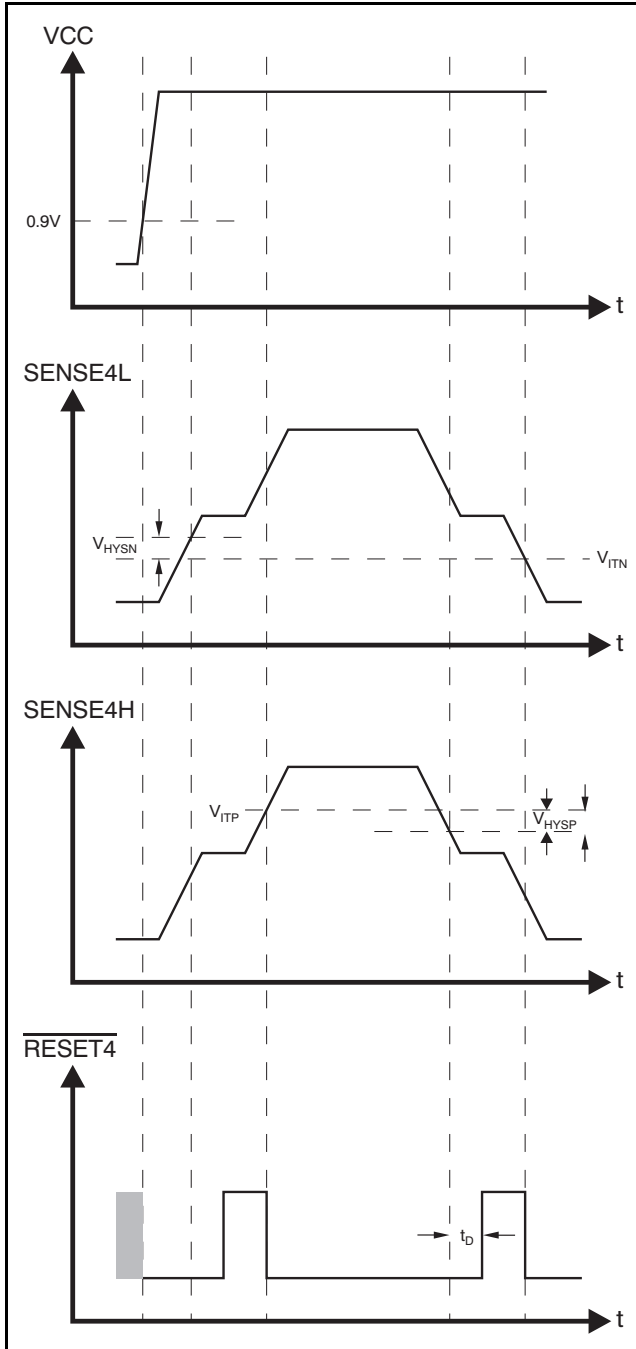

NOTE: The TPS386000 or TPS386040 is shown here using  $\overline{\text{RESETn}}$ . The TPS386020 and TPS386060 use  $\text{RESETn}$ ; therefore, the diagram of  $\overline{\text{RESETn}}$  should be read as  $\text{RESETn}$  with the opposite polarity.

Figure 29. SVS-4 Timing Diagram

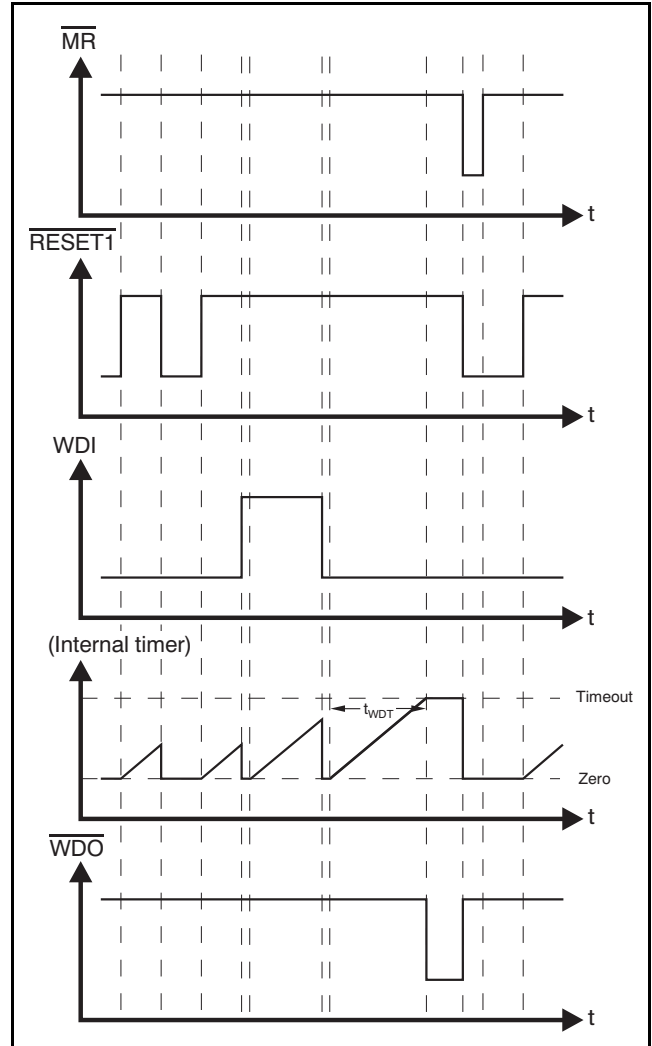

NOTE: The TPS386000 or TPS386040 is shown here using  $\overline{\text{RESETn}}$  and  $\overline{\text{WDO}}$ . The TPS386020 and TPS386060 use  $\text{RESETn}$  and  $\text{WDO}$ ; therefore, the diagrams of  $\overline{\text{RESETn}}$  and  $\overline{\text{WDO}}$  should be read as  $\text{RESETn}$  and  $\text{WDO}$  with the opposite polarities.

Figure 30. WDT Timing Diagram

## SENSE INPUT

The SENSEm inputs are pins that allow any system voltages to be monitored. If the voltage at the SENSE1, SENSE2, SENSE3, or SENSE4L pins drops below  $V_{ITN}$ , then the corresponding reset outputs are asserted. If the voltage at the SENSE4H pin exceeds  $V_{ITP}$ , then  $\overline{\text{RESET4}}$  or RESET4 is asserted. The comparators have a built-in hysteresis to ensure smooth reset output assertions and deassertions. Although not required in most cases, for extremely noise applications, it is good analog

design practice to place a 1nF to 10nF bypass capacitor at the SENSEm input in order to reduce sensitivity to transients, layout parasitics, and interference between power rails monitored by this device. A typical connection of resistor dividers are shown in Figure 31. All the SENSEm pins can be used to monitor voltage rails down to 0.4V. Threshold voltages can be calculated by following equations:

$$VCC1\_target = (1 + R_{S1H}/R_{S1L}) \times 0.4 \text{ (V)} \quad (1)$$

$$VCC2\_target = (1 + R_{S2H}/R_{S2L}) \times 0.4 \text{ (V)} \quad (2)$$

$$VCC3\_target = (1 + R_{S3H}/R_{S3L}) \times 0.4 \text{ (V)} \quad (3)$$

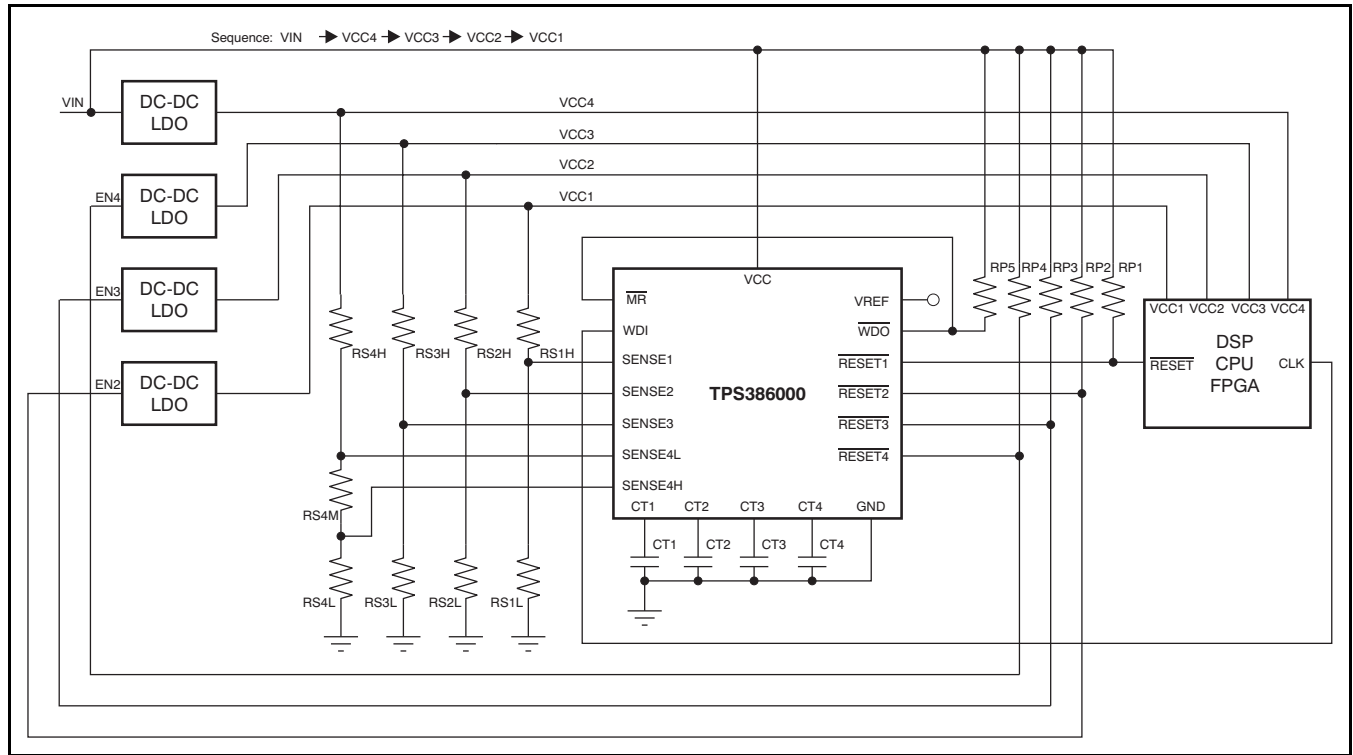

Figure 31. Typical Application Circuit

## WINDOW COMPARATOR

The comparator at the SENSE4H pin has the opposite comparison polarity to the other SENSEm pins. In the configuration shown in Figure 32, this comparator monitors overvoltage of the VCC4 node; combined with the comparator at SENSE4L, SVS-4 forms a window comparator.

$$VCC4\_target1 = \{1 + R_{S4H}/(R_{S4M} + R_{S4L})\} \times 0.4 \text{ (V)} \quad (4)$$

$$VCC4\_target2 = \{1 + (R_{S4H} + R_{S4M})/R_{S4L}\} \times 0.4 \text{ (V)} \quad (5)$$

Where VCC4\_target1 is the undervoltage threshold, and VCC4\_target2 is the overvoltage threshold.

## SENSING VOLTAGE LESS THAN 0.4V

By using voltage reference output VREF, the SVS-4 comparator can monitor negative voltage or positive voltage lower than 0.4V. Figure 33 shows this usage in an application circuit. SVS-4 monitors the positive and negative voltage power rail (for example, +15V and -15V supply to an op amp) and the RESET4 or RESET4 output status continues to be as described in Table 4. Note that R<sub>S42H</sub> is located at higher voltage position than R<sub>S42L</sub>. The threshold voltage calculations are shown in the following equations:

$$VCC41\_target = (1 + R_{S41H}/R_{S41L}) \times 0.4 \text{ (V)} \quad (6)$$

$$VCC42\_target = (1 + R_{S42L}/R_{S42H}) \times 0.4 - R_{S42L}/R_{S42H} \times V_{REF} \quad (7)$$

$$= 0.4 - (R_{S42L}/R_{S42H} \times 0.8 \text{ (V)}) \quad (8)$$

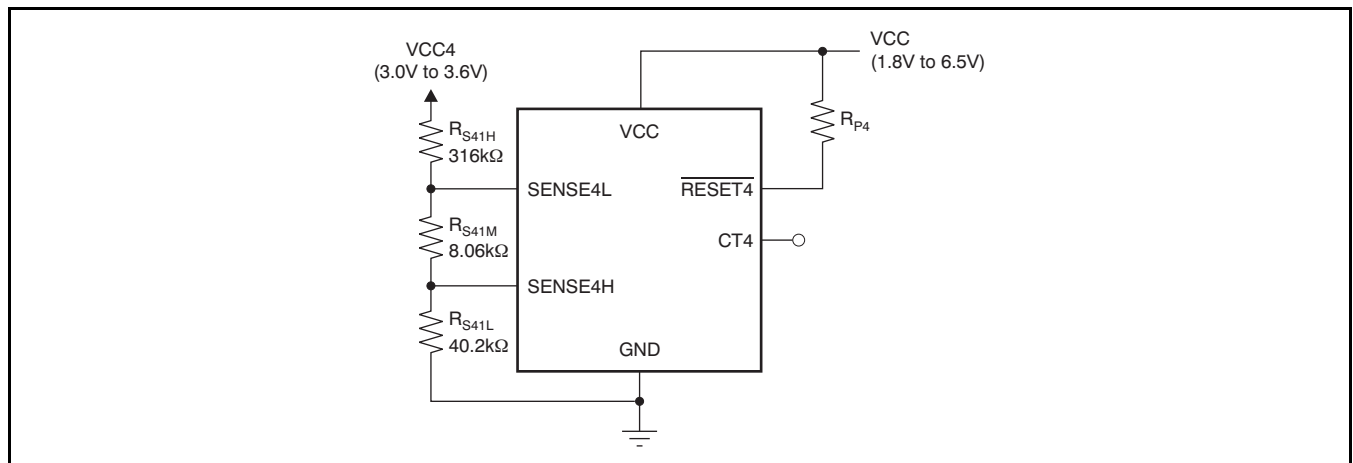

Figure 32. SVS-4: Window Comparator

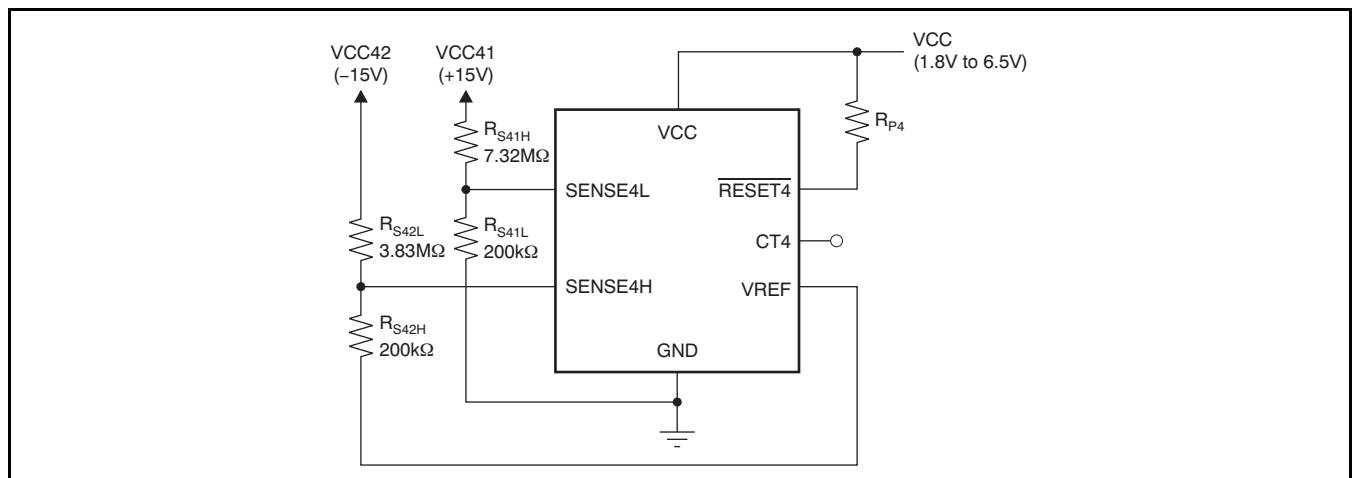

Figure 33. SVS4: Negative Voltage Sensing

## RESET DELAY TIME

Each of the SVS-n channels can be configured independently in one of three modes. [Table 6](#) describes the delay time settings.

**Table 6. Delay Timing Selection**

CTn CONNECTION	DELAY TIME
Pull-up to VCC	300ms (typ)
Open	20 ms (typ)
Capacitor to GND	Programmable

To select the 300ms fixed delay time, the CTn pin should be pulled up to VCC using a resistor from 40kΩ to 200kΩ. Please note that there is a pulldown transistor from CTn to GND that turns on every time the device powers on to determine and confirm CTn pin status; therefore, a direct connection of CTn to VCC causes a large current flow. To select the 20ms fixed delay time, the CTn pin should be left open. To program a user-defined adjustable delay time, an external capacitor must be connected between CTn and GND. The adjustable delay time can be calculated by the following equation:

$$C_{CT} \text{ (nF)} = [t_{\text{DELAY}} \text{ (ms)} - 0.5 \text{ (ms)}] \times 0.242 \quad (9)$$

Using this equation, a delay time can be set to between 1.4ms to 10s. The external capacitor should be greater than 220pF (nominal) so that the TPS3860x0 can distinguish it from an open CT pin. The reset delay time is determined by the time it takes an on-chip, precision 300nA current source to charge the external capacitor to 1.24V. When the  $\overline{\text{RESET}}_n$  or  $\text{RESET}_n$  outputs are asserted, the corresponding capacitors are discharged. When the condition to release  $\overline{\text{RESET}}_n$  or  $\text{RESET}_n$  occurs, the internal current sources are enabled and begin to charge the external capacitors. When the CTn voltage on a capacitor reaches 1.24V, the corresponding  $\overline{\text{RESET}}_n$  or  $\text{RESET}_n$  pins are released. Note that a low leakage type capacitor (such as ceramic) should be used, and that stray capacitance around this pin may cause errors in the reset delay time.

## MANUAL RESET

The manual reset ( $\overline{\text{MR}}$ ) input allows external logic signal from other processors, logic circuits, and/or discrete sensors to initiate a device reset. Because  $\overline{\text{MR}}$  is connected to SVS-1, the  $\overline{\text{RESET}}_1$  or  $\text{RESET}_1$  pin is intended to be connected to processor(s) as a primary reset source. A logic low at  $\overline{\text{MR}}$  causes  $\overline{\text{RESET}}_1$  or  $\text{RESET}_1$  to assert. After  $\overline{\text{MR}}$  returns to a

logic high and  $\text{SENSE}_1$  is above its reset threshold,  $\overline{\text{RESET}}_1$  or  $\text{RESET}_1$  is released after the user-configured reset delay time. Note that unlike the TPS3808 series, the TPS3860x0 does not integrate an internal pull-up resistor between  $\overline{\text{MR}}$  and VCC.

To control the  $\overline{\text{MR}}$  function from more than one logic signal, the logic signals can be combined by wired-OR into the  $\overline{\text{MR}}$  pin using multiple NMOS transistors and one pull-up resistor.

## WATCHDOG TIMER

The TPS3860x0 provides a watchdog timer with a dedicated watchdog error output,  $\overline{\text{WDO}}$  or WDO. The  $\overline{\text{WDO}}$  or WDO output enables application board designers to easily detect and resolve the hang-up status of a processor. As with  $\overline{\text{MR}}$ , the watchdog timer function of the device is also tied to SVS-1. [Figure 30](#) shows the timing diagram of the WDT function. Once  $\overline{\text{RESET}}_1$  or  $\text{RESET}_1$  is released, the internal watchdog timer starts its countdown. Inputting a logic level transition at WDI resets the internal timer count and the timer restarts the countdown. If the TPS3860x0 fails to receive any WDI rising or falling edge within the WDT period, the WDT times out and asserts  $\overline{\text{WDO}}$  or WDO. After  $\overline{\text{WDO}}$  or WDO is asserted, the device holds the status with the internal latch circuit. To clear this timeout status, a reset assertion of  $\overline{\text{RESET}}_1$  or  $\text{RESET}$  is required. That is, a negative pulse to  $\overline{\text{MR}}$ , a  $\text{SENSE}_1$  voltage less than  $V_{\text{ITN}}$ , or a VCC power-down is required.

To reset the processor by WDT timeout,  $\overline{\text{WDO}}$  can be combined with  $\overline{\text{RESET}}_1$  by using the wired-OR with the TPS386000 option.

For legacy applications where the watchdog timer timeout causes  $\overline{\text{RESET}}_1$  to assert, connect WDO to  $\overline{\text{MR}}$ ; see [Figure 31](#) for the connections and see [Figure 34](#) and [Figure 35](#) for the timing diagram. This legacy support configuration is available with the TPS386000 and TPS386040.

## IMMUNITY TO SENSEn VOLTAGE TRANSIENTS

The TPS3860x0 is relatively immune to short negative transients on the  $\text{SENSE}_n$  pin. Sensitivity to transients depends on threshold overdrive, as shown in the typical performance graph *TPS386040 SENSEn Minimum Pulse Width vs SENSEn Threshold Overdrive Voltage* ([Figure 11](#)).

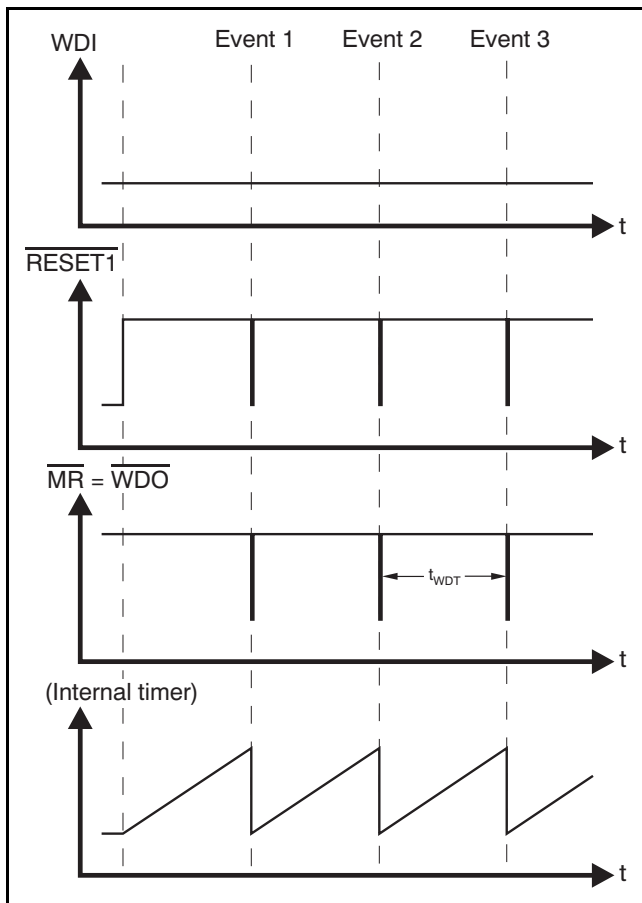

NOTE: This configuration (connecting  $\overline{WDO}$  and  $\overline{MR}$ ) is available only with the TPS386000 and TPS386040.

**Figure 34. Legacy WDT Configuration Timing Diagram**

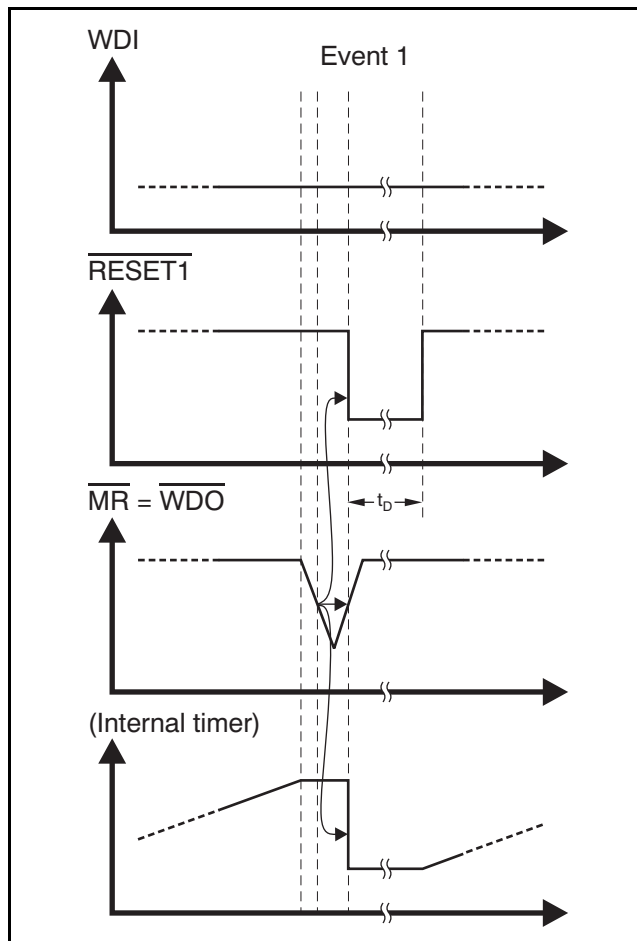

NOTE: This configuration (connecting  $\overline{WDO}$  and  $\overline{MR}$ ) is available only with the TPS386000 and TPS386040.

**Figure 35. Enlarged View of Event 1 from Figure 34**

## REVISION HISTORY

NOTE: Page numbers for previous revisions may differ from page numbers in the current version.

---

### Changes from Revision B (March 2011) to Revision C Page

- Changed [Figure 3](#) ..... 8
- 

### Changes from Revision A (January 2010) to Revision B Page

- Changed data sheet title ..... 1
  - Changed Features bullets ..... 1
  - Changed Applications bullets ..... 1
  - Changed first sentence of second paragraph in Description text ..... 1
  - Changed low quiescent current value in last paragraph of Description text from 12 $\mu$ A to 11 $\mu$ A ..... 1
  - Changed front-page typical application circuit figure ..... 1
  - Added sentence to pin 6 description in Pin Assignments table ..... 4
  - Changed last sentence of pin 13 description in Pin Assignments table ..... 4
  - Added text to first sentence of first paragraph of *General Description* section. .... 14
  - Changed caption for [Figure 31](#) ..... 19
  - Changed link in *Window Comparator* section to new [Figure 32](#) ..... 20
  - Deleted typo in [Equation 4](#) and moved [Equation 4](#) to *Window Comparator* section ..... 20
  - Deleted typo in [Equation 5](#) and moved [Equation 5](#) to *Window Comparator* section ..... 20
  - Changed link in *Sensing Voltage Less Than 0.4V* section to new [Figure 33](#) ..... 20
  - Added [Figure 32](#) ..... 20
  - Added [Figure 33](#) ..... 20
-

**PACKAGING INFORMATION**

Orderable Device	Status <sup>(1)</sup>	Package Type	Package Drawing	Pins	Package Qty	Eco Plan <sup>(2)</sup>	Lead/ Ball Finish	MSL Peak Temp <sup>(3)</sup>	Samples (Requires Login)
TPS386000RGPR	ACTIVE	QFN	RGP	20	3000	Green (RoHS & no Sb/Br)	CU NIPDAU	Level-2-260C-1 YEAR	
TPS386000RGPT	ACTIVE	QFN	RGP	20	250	Green (RoHS & no Sb/Br)	CU NIPDAU	Level-2-260C-1 YEAR	
TPS386040RGPR	ACTIVE	QFN	RGP	20	3000	Green (RoHS & no Sb/Br)	CU NIPDAU	Level-2-260C-1 YEAR	
TPS386040RGPT	ACTIVE	QFN	RGP	20	250	Green (RoHS & no Sb/Br)	CU NIPDAU	Level-2-260C-1 YEAR	

<sup>(1)</sup> The marketing status values are defined as follows:

**ACTIVE:** Product device recommended for new designs.

**LIFEBUY:** TI has announced that the device will be discontinued, and a lifetime-buy period is in effect.

**NRND:** Not recommended for new designs. Device is in production to support existing customers, but TI does not recommend using this part in a new design.

**PREVIEW:** Device has been announced but is not in production. Samples may or may not be available.

**OBSELETE:** TI has discontinued the production of the device.

<sup>(2)</sup> Eco Plan - The planned eco-friendly classification: Pb-Free (RoHS), Pb-Free (RoHS Exempt), or Green (RoHS & no Sb/Br) - please check <http://www.ti.com/productcontent> for the latest availability information and additional product content details.

**TBD:** The Pb-Free/Green conversion plan has not been defined.

**Pb-Free (RoHS):** TI's terms "Lead-Free" or "Pb-Free" mean semiconductor products that are compatible with the current RoHS requirements for all 6 substances, including the requirement that lead not exceed 0.1% by weight in homogeneous materials. Where designed to be soldered at high temperatures, TI Pb-Free products are suitable for use in specified lead-free processes.

**Pb-Free (RoHS Exempt):** This component has a RoHS exemption for either 1) lead-based flip-chip solder bumps used between the die and package, or 2) lead-based die adhesive used between the die and leadframe. The component is otherwise considered Pb-Free (RoHS compatible) as defined above.

**Green (RoHS & no Sb/Br):** TI defines "Green" to mean Pb-Free (RoHS compatible), and free of Bromine (Br) and Antimony (Sb) based flame retardants (Br or Sb do not exceed 0.1% by weight in homogeneous material)

<sup>(3)</sup> MSL, Peak Temp. -- The Moisture Sensitivity Level rating according to the JEDEC industry standard classifications, and peak solder temperature.

**Important Information and Disclaimer:** The information provided on this page represents TI's knowledge and belief as of the date that it is provided. TI bases its knowledge and belief on information provided by third parties, and makes no representation or warranty as to the accuracy of such information. Efforts are underway to better integrate information from third parties. TI has taken and continues to take reasonable steps to provide representative and accurate information but may not have conducted destructive testing or chemical analysis on incoming materials and chemicals. TI and TI suppliers consider certain information to be proprietary, and thus CAS numbers and other limited information may not be available for release.

In no event shall TI's liability arising out of such information exceed the total purchase price of the TI part(s) at issue in this document sold by TI to Customer on an annual basis.

**OTHER QUALIFIED VERSIONS OF TPS386000 :**



- Automotive: [TPS386000-Q1](#)

NOTE: Qualified Version Definitions:

- Automotive - Q100 devices qualified for high-reliability automotive applications targeting zero defects

**TAPE AND REEL INFORMATION**

**REEL DIMENSIONS**



**TAPE DIMENSIONS**



A0	Dimension designed to accommodate the component width
B0	Dimension designed to accommodate the component length
K0	Dimension designed to accommodate the component thickness
W	Overall width of the carrier tape
P1	Pitch between successive cavity centers

**TAPE AND REEL INFORMATION**

\*All dimensions are nominal

Device	Package Type	Package Drawing	Pins	SPQ	Reel Diameter (mm)	Reel Width W1 (mm)	A0 (mm)	B0 (mm)	K0 (mm)	P1 (mm)	W (mm)	Pin1 Quadrant
TPS386000RGPR	QFN	RGP	20	3000	330.0	12.4	4.25	4.25	1.15	8.0	12.0	Q2
TPS386000RGPT	QFN	RGP	20	250	180.0	12.4	4.25	4.25	1.15	8.0	12.0	Q2
TPS386040RGPR	QFN	RGP	20	3000	330.0	12.4	4.25	4.25	1.15	8.0	12.0	Q2
TPS386040RGPT	QFN	RGP	20	250	180.0	12.4	4.25	4.25	1.15	8.0	12.0	Q2

**TAPE AND REEL BOX DIMENSIONS**

\*All dimensions are nominal

Device	Package Type	Package Drawing	Pins	SPQ	Length (mm)	Width (mm)	Height (mm)
TPS386000RGPR	QFN	RGP	20	3000	367.0	367.0	35.0
TPS386000RGPT	QFN	RGP	20	250	210.0	185.0	35.0
TPS386040RGPR	QFN	RGP	20	3000	367.0	367.0	35.0
TPS386040RGPT	QFN	RGP	20	250	210.0	185.0	35.0

RGP (S-PVQFN-N20)

PLASTIC QUAD FLATPACK NO-LEAD

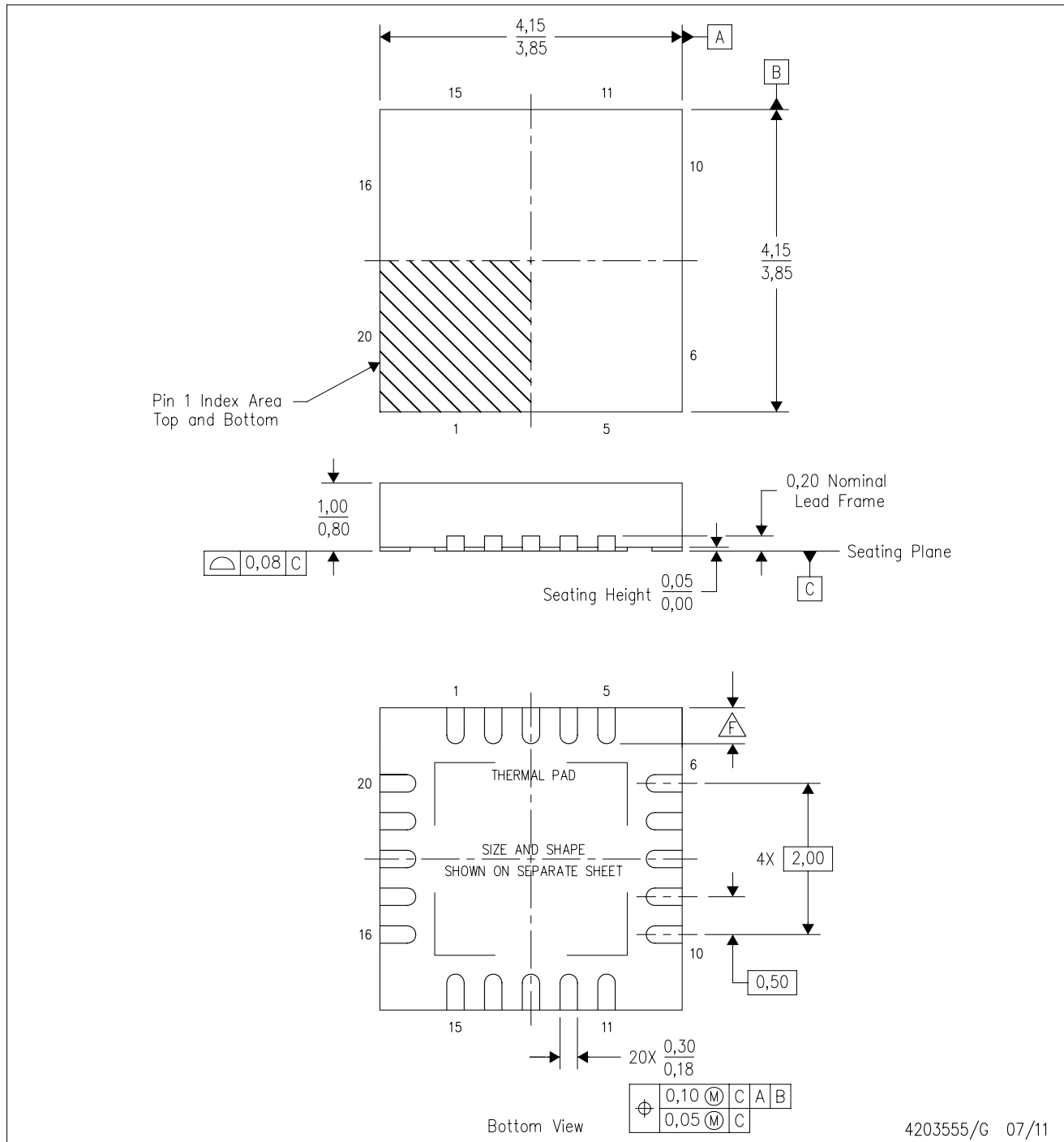

- NOTES:
- All linear dimensions are in millimeters. Dimensioning and tolerancing per ASME Y14.5M-1994.
  - This drawing is subject to change without notice.
  - QFN (Quad Flatpack No-Lead) package configuration.
  - The package thermal pad must be soldered to the board for thermal and mechanical performance.
  - See the additional figure in the Product Data Sheet for details regarding the exposed thermal pad features and dimensions.
- Check thermal pad mechanical drawing in the product datasheet for nominal lead length dimensions.

# THERMAL PAD MECHANICAL DATA

RGP (S-PVQFN-N20)

PLASTIC QUAD FLATPACK NO-LEAD

## THERMAL INFORMATION

This package incorporates an exposed thermal pad that is designed to be attached directly to an external heatsink. The thermal pad must be soldered directly to the printed circuit board (PCB). After soldering, the PCB can be used as a heatsink. In addition, through the use of thermal vias, the thermal pad can be attached directly to the appropriate copper plane shown in the electrical schematic for the device, or alternatively, can be attached to a special heatsink structure designed into the PCB. This design optimizes the heat transfer from the integrated circuit (IC).

For information on the Quad Flatpack No-Lead (QFN) package and its advantages, refer to Application Report, QFN/SON PCB Attachment, Texas Instruments Literature No. SLUA271. This document is available at [www.ti.com](http://www.ti.com).

The exposed thermal pad dimensions for this package are shown in the following illustration.

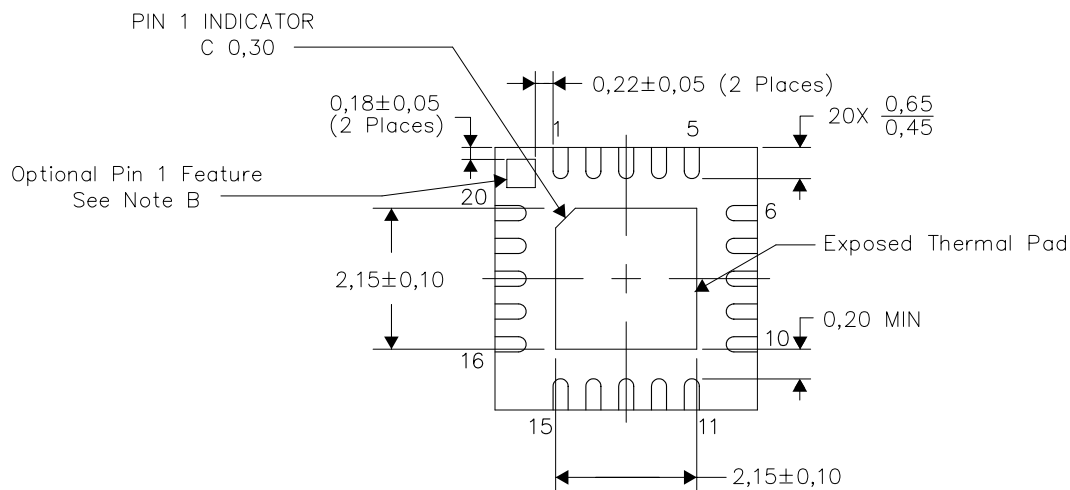

Exposed Thermal Pad Dimensions

4206346-2/X 02/12

NOTES: A. All linear dimensions are in millimeters

B. The Pin 1 Identification mark is an optional feature that may be present on some devices. In addition, this Pin 1 feature if present is electrically connected to the center thermal pad and therefore should be considered when routing the board layout.

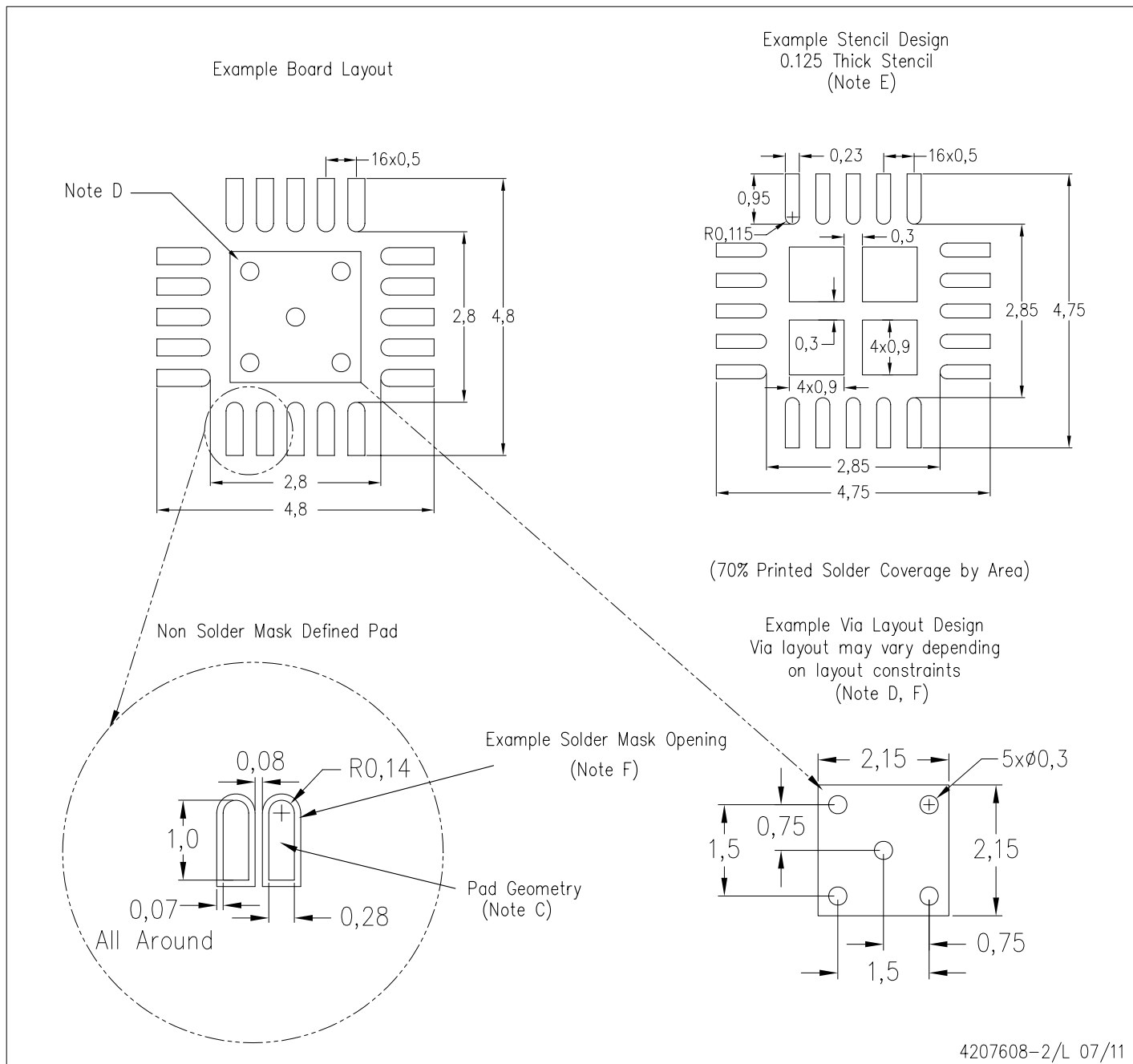

- NOTES:
- All linear dimensions are in millimeters.
  - This drawing is subject to change without notice.
  - Publication IPC-7351 is recommended for alternate designs.
  - This package is designed to be soldered to a thermal pad on the board. Refer to Application Note, Quad Flat-Pack Packages, Texas Instruments Literature No. SLUA271, and also the Product Data Sheets for specific thermal information, via requirements, and recommended board layout. These documents are available at [www.ti.com](http://www.ti.com) <<http://www.ti.com>>.
  - Laser cutting apertures with trapezoidal walls and also rounding corners will offer better paste release. Customers should contact their board assembly site for stencil design recommendations. Refer to IPC 7525 for stencil design considerations.
  - Customers should contact their board fabrication site for recommended solder mask tolerances and via tenting recommendations for vias placed in the thermal pad.

## IMPORTANT NOTICE

Texas Instruments Incorporated and its subsidiaries (TI) reserve the right to make corrections, enhancements, improvements and other changes to its semiconductor products and services per JESD46C and to discontinue any product or service per JESD48B. Buyers should obtain the latest relevant information before placing orders and should verify that such information is current and complete. All semiconductor products (also referred to herein as "components") are sold subject to TI's terms and conditions of sale supplied at the time of order acknowledgment.

TI warrants performance of its components to the specifications applicable at the time of sale, in accordance with the warranty in TI's terms and conditions of sale of semiconductor products. Testing and other quality control techniques are used to the extent TI deems necessary to support this warranty. Except where mandated by applicable law, testing of all parameters of each component is not necessarily performed.

TI assumes no liability for applications assistance or the design of Buyers' products. Buyers are responsible for their products and applications using TI components. To minimize the risks associated with Buyers' products and applications, Buyers should provide adequate design and operating safeguards.

TI does not warrant or represent that any license, either express or implied, is granted under any patent right, copyright, mask work right, or other intellectual property right relating to any combination, machine, or process in which TI components or services are used. Information published by TI regarding third-party products or services does not constitute a license to use such products or services or a warranty or endorsement thereof. Use of such information may require a license from a third party under the patents or other intellectual property of the third party, or a license from TI under the patents or other intellectual property of TI.

Reproduction of significant portions of TI information in TI data books or data sheets is permissible only if reproduction is without alteration and is accompanied by all associated warranties, conditions, limitations, and notices. TI is not responsible or liable for such altered documentation. Information of third parties may be subject to additional restrictions.

Resale of TI components or services with statements different from or beyond the parameters stated by TI for that component or service voids all express and any implied warranties for the associated TI component or service and is an unfair and deceptive business practice. TI is not responsible or liable for any such statements.

Buyer acknowledges and agrees that it is solely responsible for compliance with all legal, regulatory and safety-related requirements concerning its products, and any use of TI components in its applications, notwithstanding any applications-related information or support that may be provided by TI. Buyer represents and agrees that it has all the necessary expertise to create and implement safeguards which anticipate dangerous consequences of failures, monitor failures and their consequences, lessen the likelihood of failures that might cause harm and take appropriate remedial actions. Buyer will fully indemnify TI and its representatives against any damages arising out of the use of any TI components in safety-critical applications.

In some cases, TI components may be promoted specifically to facilitate safety-related applications. With such components, TI's goal is to help enable customers to design and create their own end-product solutions that meet applicable functional safety standards and requirements. Nonetheless, such components are subject to these terms.

No TI components are authorized for use in FDA Class III (or similar life-critical medical equipment) unless authorized officers of the parties have executed a special agreement specifically governing such use.

Only those TI components which TI has specifically designated as military grade or "enhanced plastic" are designed and intended for use in military/aerospace applications or environments. Buyer acknowledges and agrees that any military or aerospace use of TI components which have **not** been so designated is solely at the Buyer's risk, and that Buyer is solely responsible for compliance with all legal and regulatory requirements in connection with such use.

TI has specifically designated certain components which meet ISO/TS16949 requirements, mainly for automotive use. Components which have not been so designated are neither designed nor intended for automotive use; and TI will not be responsible for any failure of such components to meet such requirements.

### Products

Audio	<a href="http://www.ti.com/audio">www.ti.com/audio</a>
Amplifiers	<a href="http://amplifier.ti.com">amplifier.ti.com</a>
Data Converters	<a href="http://dataconverter.ti.com">dataconverter.ti.com</a>
DLP® Products	<a href="http://www.dlp.com">www.dlp.com</a>
DSP	<a href="http://dsp.ti.com">dsp.ti.com</a>
Clocks and Timers	<a href="http://www.ti.com/clocks">www.ti.com/clocks</a>
Interface	<a href="http://interface.ti.com">interface.ti.com</a>
Logic	<a href="http://logic.ti.com">logic.ti.com</a>
Power Mgmt	<a href="http://power.ti.com">power.ti.com</a>
Microcontrollers	<a href="http://microcontroller.ti.com">microcontroller.ti.com</a>
RFID	<a href="http://www.ti-rfid.com">www.ti-rfid.com</a>
OMAP Mobile Processors	<a href="http://www.ti.com/omap">www.ti.com/omap</a>
Wireless Connectivity	<a href="http://www.ti.com/wirelessconnectivity">www.ti.com/wirelessconnectivity</a>

### Applications

Automotive and Transportation	<a href="http://www.ti.com/automotive">www.ti.com/automotive</a>
Communications and Telecom	<a href="http://www.ti.com/communications">www.ti.com/communications</a>
Computers and Peripherals	<a href="http://www.ti.com/computers">www.ti.com/computers</a>
Consumer Electronics	<a href="http://www.ti.com/consumer-apps">www.ti.com/consumer-apps</a>
Energy and Lighting	<a href="http://www.ti.com/energy">www.ti.com/energy</a>
Industrial	<a href="http://www.ti.com/industrial">www.ti.com/industrial</a>
Medical	<a href="http://www.ti.com/medical">www.ti.com/medical</a>
Security	<a href="http://www.ti.com/security">www.ti.com/security</a>
Space, Avionics and Defense	<a href="http://www.ti.com/space-avionics-defense">www.ti.com/space-avionics-defense</a>
Video and Imaging	<a href="http://www.ti.com/video">www.ti.com/video</a>

**TI E2E Community** [e2e.ti.com](http://e2e.ti.com)