

## INTEGRATED PHOTO FLASH CHARGER AND IGBT DRIVER

### FEATURES

- Highly Integrated Solution to Reduce Components
- Integrated Voltage Reference
- Integrated 50-V Power Switch,
- Integrated IGBT Driver
- High Efficiency
- Programmable Peak Current: 1.1 A to 2.2 A
- Input Battery Voltage of 1.6 V to 12 V
- Optimized Control Loop for Fast Charge Time
- Output Voltage Feedback From Primary Side
- 16-Pin QFN Package
- Protection
  - MAX On Time
  - MAX Off Time
  - Overcurrent Shutdown to Monitor  $V_{DS}$  at the SW pin ( $OV_{DS}$ )
  - Thermal Monitor

### APPLICATIONS

- Digital Still Cameras
- Optical Film Cameras

### DESCRIPTION

This device offers a complete solution for charging a photo flash capacitor from a battery input, and subsequently discharging the capacitor to a xenon flash tube. The device has an integrated voltage reference, power switch, IGBT driver, and control logic blocks for capacitor charging applications and driving IGBT applications. Compared with discrete solutions, this device reduces the component count, shrinks the solution size, and eases designs for xenon tube applications. Additional advantages are a fast charging time and high efficiency from an optimized PWM control algorithm.

Other provisions of the device includes sensing the output voltage from the primary side, programmable peak current, thermal shutdown, an output pin for charge completion, and input pins for charge enable and flash enable.

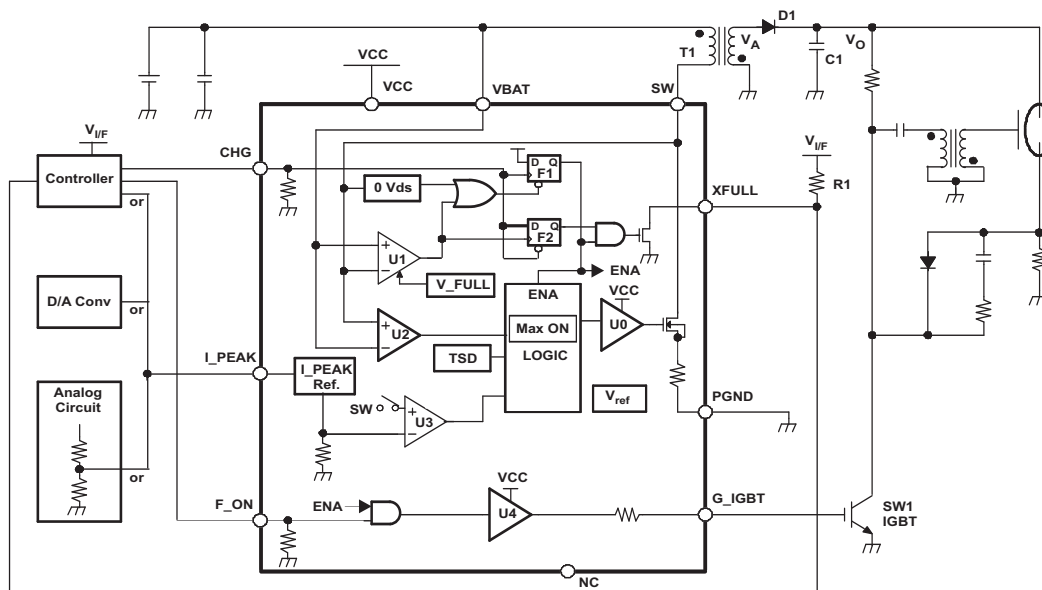

Figure 1. Typical Application Circuit



Please be aware that an important notice concerning availability, standard warranty, and use in critical applications of Texas Instruments semiconductor products and disclaimers thereto appears at the end of this data sheet.

PowerPAD is a trademark of Texas Instruments.



These devices have limited built-in ESD protection. The leads should be shorted together or the device placed in conductive foam during storage or handling to prevent electrostatic damage to the MOS gates.

### ORDERING INFORMATION

T <sub>A</sub>	PACKAGE MARKING	PACKAGE <sup>(1)</sup>	PART NUMBER
-35°C to 70°C	BUO	16-pin QFN	TPS65561RGT

(1) For the most current package and ordering information, see the Package Option Addendum at the end of this document, or see the TI Web site at [www.ti.com](http://www.ti.com).

### ABSOLUTE MAXIMUM RATINGS

over operating free-air temperature range (unless otherwise noted) <sup>(1)</sup>

			UNIT
V <sub>SS</sub>	Supply voltage	VCC	-0.6 V to 6 V
		VBAT	-0.6 V to 13 V
V <sub>(SW)</sub>	Switch terminal voltage		-0.6 V to 50 V
I <sub>(SW)</sub>	Switch current between SW and PGND		3 A
V <sub>I</sub>	Input voltage of CHG, I_PEAK, F_ON		-0.3 V to V <sub>CC</sub>
T <sub>stg</sub>	Storage temperature		-40°C to 150°C
T <sub>J</sub>	Maximum junction temperature		125°C
	ESD rating	HBM (Human Body Model) JEDEC JES22-A114	1kV

(1) Stresses beyond those listed under "absolute maximum ratings" may cause permanent damage to the device. These are stress ratings only and functional operation of the device at these or any other conditions beyond those indicated under "recommended operating conditions" is not implied. Exposure to absolute-maximum-rated conditions for extended periods may affect device reliability.

### RECOMMENDED OPERATING CONDITIONS

		MIN	NOM	MAX	UNIT
V <sub>SS</sub>	Supply voltage, VCC	2.7		4	V
	Supply voltage, VBAT	1.6		12	V
V <sub>(SW)</sub>	Switch terminal voltage	-0.3		45	V
I <sub>(SW)</sub>	Switch current between SW and PGND			2.5	A
	Operating free-air temperature range	-35		70	°C
V <sub>IH</sub>	High-level digital input voltage at CHG and F_ON	2			V
V <sub>IL</sub>	Low-level digital input voltage at CHG and F_ON			0.5	V

### DISSIPATION RATINGS

PACKAGE	R <sub>θJA</sub> <sup>(1)</sup>	POWER RATING T <sub>A</sub> < 25°C	POWER RATING T <sub>A</sub> = 70°C
QFN	47.4 °C/W	2.11 W	1.16 W

(1) The thermal resistance, R<sub>θJA</sub>, is based on a soldered PowerPAD™ on a 2S2P JEDEC board using thermal vias.

## ELECTRICAL CHARACTERISTICS

$T_A = 25^\circ\text{C}$ ,  $V_{BAT} = 4.2\text{ V}$ ,  $V_{CC} = 3\text{ V}$ ,  $V_{(SW)} = 4.2\text{ V}$  (unless otherwise noted)

PARAMETER	TEST CONDITIONS	MIN	TYP	MAX	UNIT	
$R_{(ONL)}$	ON resistance of XFULL		1.5	3	$k\Omega$	
$V_{(PKH)}^{(1)}$	Upper threshold voltage of $I_{PEAK}$	$V_{CC} = 3\text{ V}$	2.4		V	
$V_{(PKL)}^{(1)}$	Lower threshold voltage of $I_{PEAK}$	$V_{CC} = 3\text{ V}$		0.6	V	
$I_{CC1}$	Supply current from VBAT	CHG = H, $V_{(SW)} = 0\text{ V}$ (free run by $t_{MAX}$ )	17	50	$\mu\text{A}$	
$I_{CC2}$	Supply current from VCC	CHG = H, $V_{(SW)} = 0\text{ V}$ (free run by $t_{MAX}$ )	1.3	3	mA	
$I_{CC3}$	Supply current from VCC and VBAT	CHG = L		1	$\mu\text{A}$	
$I_{lkg1}$	Leakage current of SW terminal			2	$\mu\text{A}$	
$I_{lkg2}$	Leakage current of XFULL terminal	$V_{(XFULL)} = 5\text{ V}$		1	$\mu\text{A}$	
$I_{(sink)}$	Sink current at $I_{PEAK}$	$V_{(L\_PEAK)} = 3\text{ V}$ , CHG: High		2	$\mu\text{A}$	
		$V_{(L\_PEAK)} = 3\text{ V}$ , CHG: Low		0.1		
$R_{(ONSW)}$	SW ON resistance between SW and PGND	$I_{(SW)} = 1\text{ A}$ , $V_{CC} = 3\text{ V}$	0.4	0.9	$\Omega$	
$R_{(IGBT1)}$	G_IGBT pullup resistance	$V_{(G\_IGBT)} = 0\text{ V}$ , $V_{CC} = 3\text{ V}$	8	12	19.4	$\Omega$
$R_{(IGBT2)}$	G_IGBT pulldown resistance	$V_{(G\_IGBT)} = 3\text{ V}$ , $V_{CC} = 3\text{ V}$	36	53	70	$\Omega$
$I_{(PEAK1)}$	Upper peak of $I_{(SW)}$	$V_{(L\_PEAK)} = 3\text{ V}$	2	2.2	2.4	A
$I_{(PEAK2)}$	Lower peak of $I_{(SW)}$	$V_{(L\_PEAK)} = 0\text{ V}$	1	1.1	1.2	A
$V_{(FULL)}$	Charge completion detect voltage at $V_{(SW)}$	$V_{BAT} = 1.6\text{ V}$ , $V_{CC} = 3\text{ V}$	28	28.7	29.4	V
		$V_{CC} = 3\text{ V}$	28.6	29	29.4	
$V_{(ZERO)}$	Zero current detection at $V_{(SW)}$		1	20	60	mV
$T_{(SD)}^{(1)}$	Thermal shutdown temperature		150	160	170	$^\circ\text{C}$
	Over $V_{DS}$ detection at $V_{(SW)}$		1.35	1.65	1.95	V
$t_{MIN}$	MAX OFF time		25	50	80	$\mu\text{s}$
$t_{MAX}$	MAX ON time		50	100	160	$\mu\text{s}$
$R_{(INPD)}$	Pulldown resistance of CHG, F_ON	$V_{CHG} = V_{(F\_ON)} = 4.2\text{ V}$		100		$k\Omega$

(1) Specified by design.

## SWITCHING CHARACTERISTICS

$T_A = 25^\circ\text{C}$ ,  $V_{BAT} = 4.2\text{ V}$ ,  $V_{CC} = 3\text{ V}$ ,  $V_{(SW)} = 4.2\text{ V}$  (unless otherwise noted)

PARAMETER	TEST CONDITIONS	MIN	TYP	MAX	UNIT	
$t_{PD}^{(1)}$	Propagation delay					
		F_ON $\uparrow$ - G_IGBT $\downarrow$		50		ns
		SW ON after $V_{(SW)}$ dips from $V_{(ZERO)}$		500		ns
		SW OFF after $I_{(SW)}$ exceeds $I_{(PEAK)}$		270		ns
		XFULL $\downarrow$ after $V_{(SW)}$ exceeds $V_{(FULL)}$		400		ns
		SW ON after CHG $\uparrow$		12		$\mu\text{s}$
	SW OFF after CHG $\downarrow$		20		ns	

(1) Specified by design.

**PIN ASSIGNMENT**

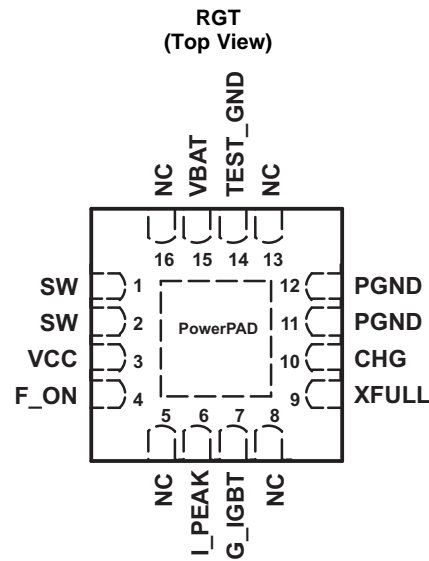

NC – No internal connection

**TERMINAL FUNCTIONS**

PIN NUMBER	SIGNAL	I/O	DESCRIPTION
1, 2	SW	O	Primary side switch. Connect SW to the switched side of the transformer
3	VCC	I	Power supply input. Connect VCC to an input supply from 2.7 V to 4 V. Bypass VCC to GND with a 1- $\mu$ F ceramic capacitor as close as possible to the IC.
4	F_ON	I	IGBT gate control input. A logic high on F_ON when CHG is low will drive the gate of the IGBT high to initiate a flash. See the <i>IGBT Driver Control</i> section <a href="#">SubSec1 1</a> for details.
5, 8, 13, 16	NC		No internal connection.
6	I_PEAK	I	Primary side peak current control input. The voltage at I_PEAK sets the peak current into SW. See the <i>Programming Peak Current</i> section for details on selecting $V_{(I\_PEAK)}$ .
7	G_IGBT	O	IGBT gate driver output. G_IGBT swings from PGND to VCC to drive external IGBT devices.
9	XFULL	O	Charge completion indicator output. XFULL is an open-drain output that pulls low once the output is fully charged. XFULL is high impedance during charging and all fault conditions. XFULL is reset when CHG turns Low from High. See the <i>Indicating Charging Status</i> section for details.
10	CHG	I	Charge control input. Drive CHG high to initiate charging of the output. Drive CHG low to terminate charging.
11, 12	PGND		Power ground. Connect to the ground plane.
14	TEST_GND		Used by TI, should be connected to PGND and ground plane.
15	VBAT	I	Battery voltage monitor input. Connect VBAT to an input supply from 1.6 V to 12 V. Bypass VBAT to GND with a 10- $\mu$ F ceramic capacitor (C1 in <a href="#">Figure 1</a> , as close as possible to the battery) and a 1- $\mu$ F ceramic capacitor (C2 in <a href="#">Figure 1</a> , as close as possible to the IC). There are no power sequencing requirements between VBAT and VCC.

FUNCTIONAL BLOCK DIAGRAM

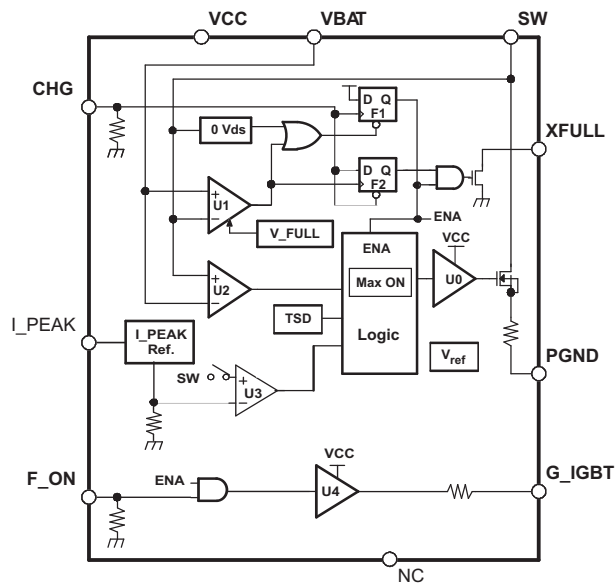

Figure 2. Functional Block Diagram

I/O Equivalent Circuits

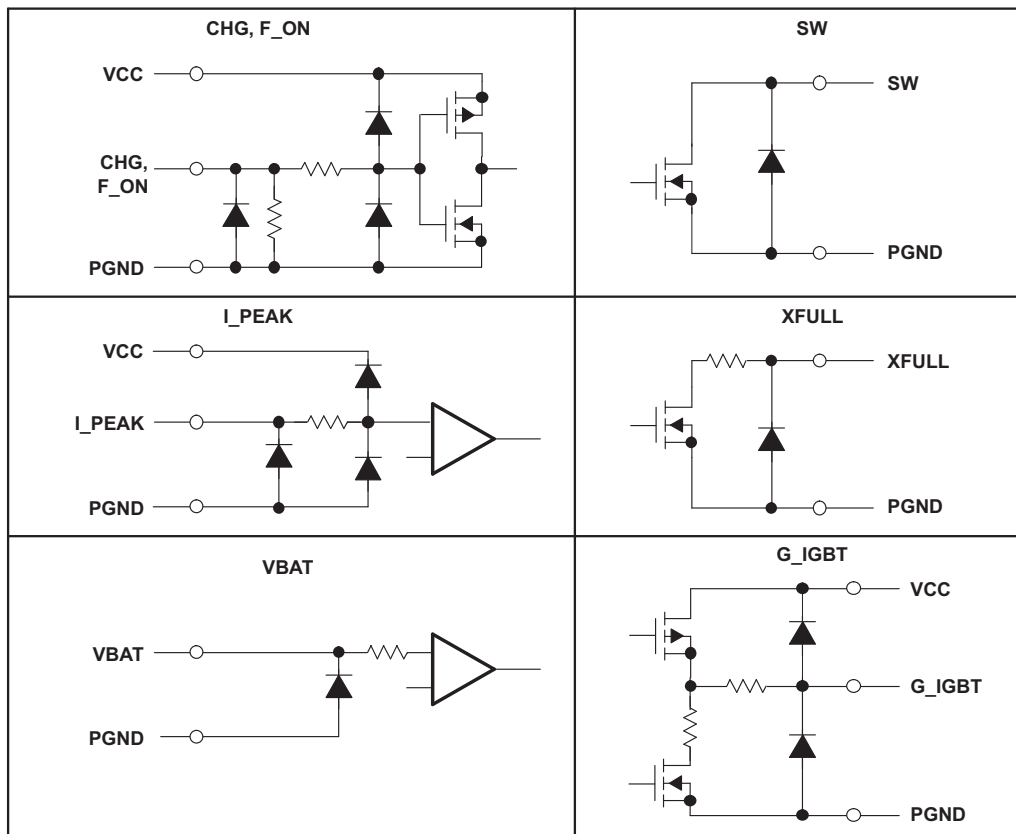

Figure 3. I/O Equivalent Circuits

## PRINCIPLES OF OPERATION

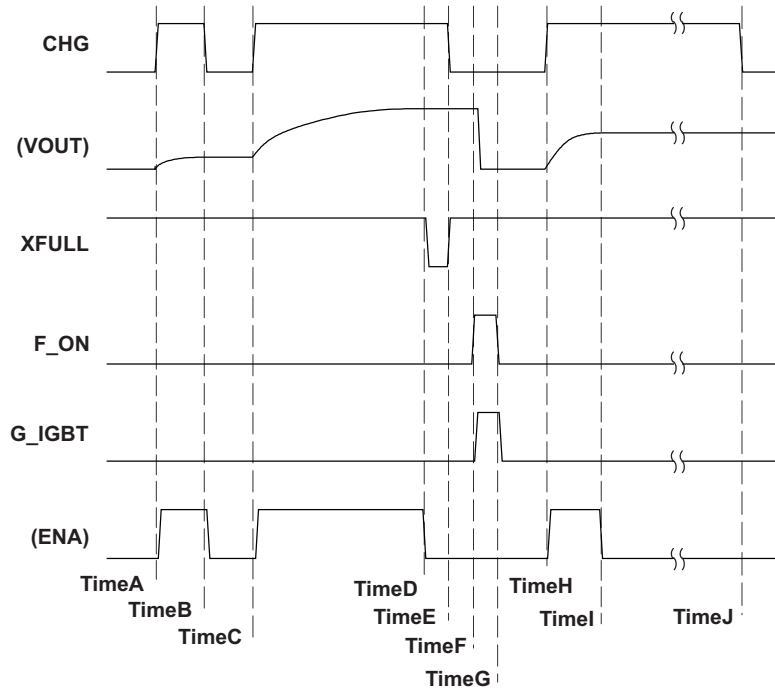

Figure 4. Whole Operation Sequence Chart

### Start/Stop Charging

TPS65561 has one internal enable latch, F1, that holds the charge enable (*ON/OFF* status) of the device. See [Figure 2](#).

The only way to *start* charging is to input  $\text{CHG}\uparrow$  (see time A/C/H in [Figure 4](#)). Each time  $\text{CHG}\uparrow$  is applied, the TPS65561 starts charging.

There are three trigger events to *stop* charging:

1. Forced *stop* by inputting  $\text{CHG} = \text{L}$  from the controller (see timeB in [Figure 4](#)).
2. Automatic *stop* by detecting a full charge. *VOUT* reaches the target value (see TimeD in [Figure 4](#)).
3. Protected *stop* by detecting an over current function ( $\text{OV}_{\text{DS}}$ ) trigger at SW pin (see TimeI in [Figure 4](#)).

### Indicating Charging Status

When the charging operation is complete, the TPS65561 drives the charge completion indicator pin, *XFULL*, to GND. A controller can detect the status of the device as a logic signal when connected through a pullup resistor, R1 (see [Figure 1](#)).

The *XFULL* output enables the controller to detect the  $\text{OV}_{\text{DS}}$  protection status. If  $\text{OV}_{\text{DS}}$  protection occurs, *XFULL* never goes L during  $\text{CHG} = \text{H}$ . Therefore, the controller detects  $\text{OV}_{\text{DS}}$  protection by measuring the time from *CHG* high to *XFULL* low. If the time to *XFULL* low is longer than the maximum designed charge time, then an  $\text{OV}_{\text{DS}}$  protection occurred.

The device starts charging at *timeH*, and  $\text{OV}_{\text{DS}}$  protection occurs at *TimeI* (see [Figure 4](#)). At *TimeI*, *XFULL* stays high. At *TimeJ*, the controller detects  $\text{OV}_{\text{DS}}$  protection through the expiration of a timer and then sets *CHG* to low to terminate the operation.

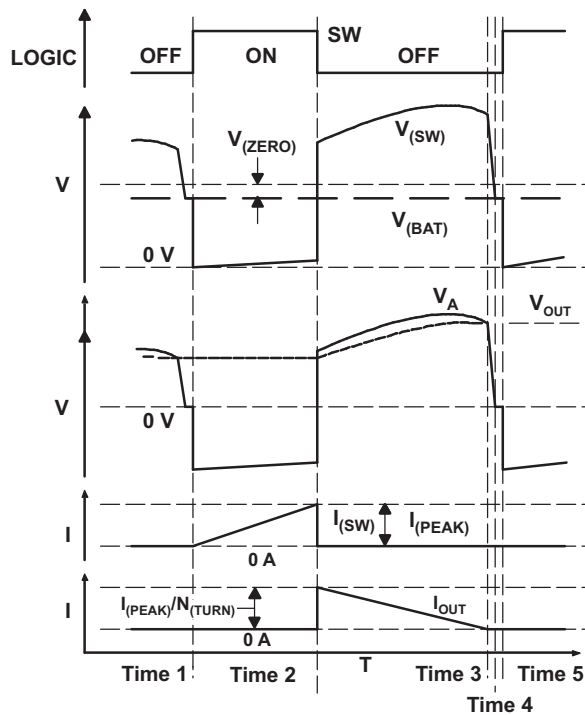

Figure 5. Timing Diagram at One Switching Cycle

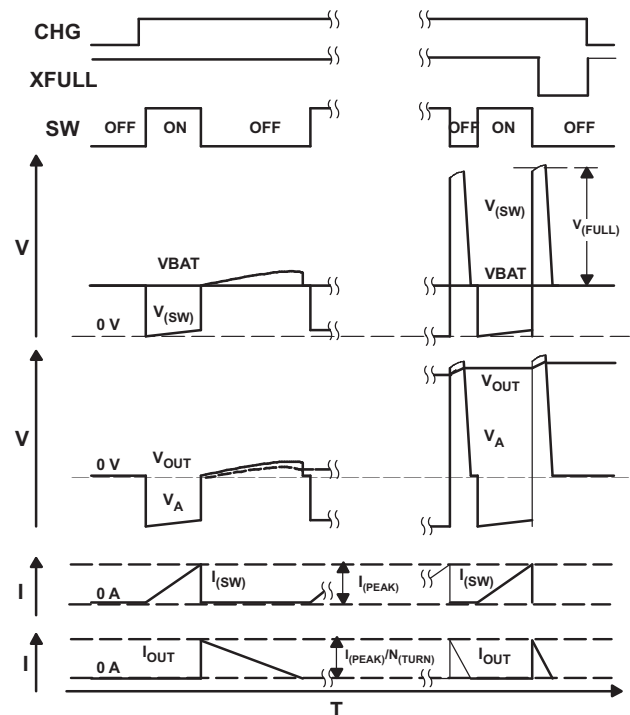

Figure 6. Timing Diagram at Beginning/Ending

## Control Charging

The TPS65561 provides three comparators to control charging. Figure 2 shows the block diagram of TPS65561 and Figure 5 shows a timing diagram of one switch cycle. Note that emphasis is placed on Time1 and Time3 of the waveform in Figure 5.

While SW is ON (Time1 to Time2 in Figure 5), U3 monitors current flow through the integrated power switch from SW pin to GND. When  $I_{(SW)}$  exceeds  $I_{(PEAK)}$ , SW turns OFF (Time2 in Figure 5).

When SW turns OFF (Time2 in Figure 5), the magnetic energy in the transformer starts discharging. Meanwhile, U2 monitors the kickback voltage at the SW terminal. As the energy is discharging, the kickback voltage is increasing according to the increase of  $V_O$  (Time2 to Time3 in Figure 5). When almost all energy is discharged, the system cannot continue rectification via the diode, and the charging current of  $I_O$  goes to zero (Times3 in Figure 5). After rectification stops, the small amount of energy left in the transformer is released via parasitic paths, and the kickback voltage reaches zero (Time3 to Time4 in Figure 5). During this period, U2 makes SW turn ON when  $(V_{(SW)} - V_{(BAT)})$  dips from  $V_{(ZERO)}$  (Time5 in Figure 5). In the actual circuit, the period between Time4 and Time5 in Figure 5 is small or does not appear dependent on the delay time of the U2 detection to SW ON.

U1 also monitors the kickback voltage. When  $(V_{(SW)} - V_{(BAT)})$  exceeds  $V_{(FULL)}$ , the TPS65561 stops charging (see Figure 6).

In Figure 5 and Figure 6, ON time is always the same period in every switch cycle. The ON time is calculated by Equation 1.  $L$  and  $I_{(PEAK)}$  are selected to ensure that  $t_{ON}$  does not exceed the MAX ON time ( $t_{MAX}$ ).

$$t_{ON} = L \frac{I_{PEAK}}{V_{BAT}} \quad (1)$$

The OFF time is dependant on output voltage. As the output voltage gets higher, the OFF time gets shorter (see Equation 2).

$$t_{OFF} = N_{TURN} \times L \frac{I_{PEAK}}{V_{OUT}} \tag{2}$$

### Programming Peak Current

The TPS65561 provides a method to program the peak primary current with a voltage applied to the I\_PEAK pin. Figure 7 shows how to program I<sub>(PEAK)</sub>.

The I\_PEAK input is treated as a logic input below V<sub>(PKL)</sub> (0.6 V) and above V<sub>(PKH)</sub> (2.4 V). Between V<sub>(PKL)</sub> and V<sub>(PKH)</sub>, I\_PEAK input is treated as an analog input. Using this characteristic, I<sub>(PEAK)</sub> can be set by a logic signal or by an analog input.

Typical usages of this function are:

1. Setting the peak charging currents based on the battery voltage. Larger I<sub>(PEAK)</sub> for a fully charged battery and lower I<sub>(PEAK)</sub> for a discharged battery.
2. Reducing I<sub>(PEAK)</sub> when powering a zooming lens motor. This avoids inadvertent shutdowns due to large current from the battery.

In Figure 1, three optional connections to I\_PEAK are shown.

1. Use the controller to treat I\_PEAK as the logic input pin. This option is the easiest.
2. Use a D/A converter to force I<sub>(PEAK)</sub> to follow analog information, such as battery voltage.
3. Use an analog circuit to achieve the same results as the D/A converter.

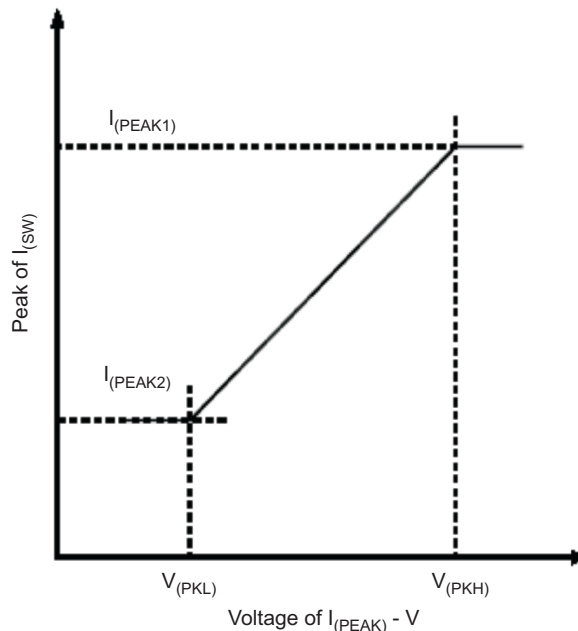

Figure 7. I\_PEAK vs I<sub>(sw)</sub>



## IGBT Driver Control

The IGBT driver is provided by the TPS65561. The driver voltage depends on VCC. TPS65561 has a mask filter as shown in Figure 8. The mask does not have hysteresis; therefore, there is no wait time from CHG forcing Low after FULL CHARGE to F\_ON turning High.

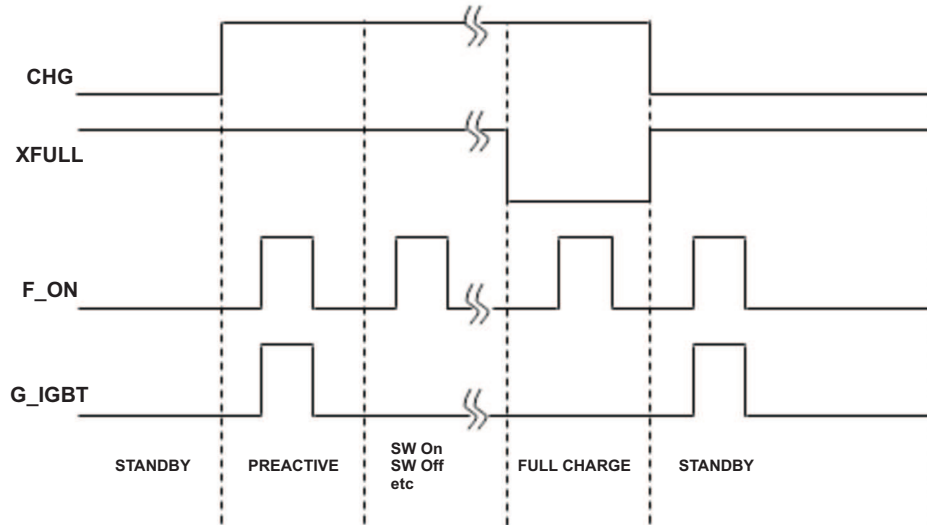

Figure 8. IGBT Timing Diagram

## Protections

TPS65561 provides four protection mechanisms: max on time, max off time, thermal disable, and overcurrent shutdown.

### MAX On Time

To prevent a condition such as pulling current from a poor power source (i.e., an almost empty battery), and never reaching peak current, the TPS65561 provides a maximum ON time function. If the ON time exceeds  $t_{MAX}$ , the TPS65561 is forced OFF regardless of  $I_{(PEAK)}$  detection.

### MAX Off Time

To prevent a condition such as never increasing the voltage at the SW pin when the internal FET is OFF, the TPS65561 provides a maximum OFF time function. If the OFF time exceeds  $t_{MIN}$ , the TPS65561 is forced ON regardless of  $V_{(ZERO)}$  detection.

### Thermal Disable

Once the TPS65561 die temperature reaches 160°C, all functions stop. Once the die cools below 160°C, the TPS65561 restarts charging if CHG remains high during the entire overtemperature condition.

### Overcurrent Shutdown to Monitor $V_{DS}$ at the SW Pin ( $OV_{DS}$ )

The TPS65561 provides an overvoltage monitor function of the SW pin. The TPS65561 is latched off if the voltage on the SW pin is above  $OV_{DS}$  during the switch ON time (see Figure 4 and its descriptions).

This function protects against a shorted primary winding of the flyback transformer. A short-circuit on the primary winding shorts the battery voltage to GND through the SW pin which could damage the device.

**PACKAGING INFORMATION**

Orderable Device	Status <sup>(1)</sup>	Package Type	Package Drawing	Pins	Package Qty	Eco Plan <sup>(2)</sup>	Lead/Ball Finish	MSL Peak Temp <sup>(3)</sup>
TPS65561RGTR	ACTIVE	QFN	RGT	16	3000	Green (RoHS & no Sb/Br)	CU NIPDAU	Level-2-260C-1 YEAR
TPS65561RGTRG4	ACTIVE	QFN	RGT	16	3000	Green (RoHS & no Sb/Br)	CU NIPDAU	Level-2-260C-1 YEAR
TPS65561RGTT	ACTIVE	QFN	RGT	16	250	Green (RoHS & no Sb/Br)	CU NIPDAU	Level-2-260C-1 YEAR
TPS65561RGTTG4	ACTIVE	QFN	RGT	16	250	Green (RoHS & no Sb/Br)	CU NIPDAU	Level-2-260C-1 YEAR

<sup>(1)</sup> The marketing status values are defined as follows:

**ACTIVE:** Product device recommended for new designs.

**LIFEBUY:** TI has announced that the device will be discontinued, and a lifetime-buy period is in effect.

**NRND:** Not recommended for new designs. Device is in production to support existing customers, but TI does not recommend using this part in a new design.

**PREVIEW:** Device has been announced but is not in production. Samples may or may not be available.

**OBSOLETE:** TI has discontinued the production of the device.

<sup>(2)</sup> Eco Plan - The planned eco-friendly classification: Pb-Free (RoHS), Pb-Free (RoHS Exempt), or Green (RoHS & no Sb/Br) - please check <http://www.ti.com/productcontent> for the latest availability information and additional product content details.

**TBD:** The Pb-Free/Green conversion plan has not been defined.

**Pb-Free (RoHS):** TI's terms "Lead-Free" or "Pb-Free" mean semiconductor products that are compatible with the current RoHS requirements for all 6 substances, including the requirement that lead not exceed 0.1% by weight in homogeneous materials. Where designed to be soldered at high temperatures, TI Pb-Free products are suitable for use in specified lead-free processes.

**Pb-Free (RoHS Exempt):** This component has a RoHS exemption for either 1) lead-based flip-chip solder bumps used between the die and package, or 2) lead-based die adhesive used between the die and leadframe. The component is otherwise considered Pb-Free (RoHS compatible) as defined above.

**Green (RoHS & no Sb/Br):** TI defines "Green" to mean Pb-Free (RoHS compatible), and free of Bromine (Br) and Antimony (Sb) based flame retardants (Br or Sb do not exceed 0.1% by weight in homogeneous material)

<sup>(3)</sup> MSL, Peak Temp. -- The Moisture Sensitivity Level rating according to the JEDEC industry standard classifications, and peak solder temperature.

**Important Information and Disclaimer:**The information provided on this page represents TI's knowledge and belief as of the date that it is provided. TI bases its knowledge and belief on information provided by third parties, and makes no representation or warranty as to the accuracy of such information. Efforts are underway to better integrate information from third parties. TI has taken and continues to take reasonable steps to provide representative and accurate information but may not have conducted destructive testing or chemical analysis on incoming materials and chemicals. TI and TI suppliers consider certain information to be proprietary, and thus CAS numbers and other limited information may not be available for release.

In no event shall TI's liability arising out of such information exceed the total purchase price of the TI part(s) at issue in this document sold by TI to Customer on an annual basis.

TAPE AND REEL INFORMATION

REEL DIMENSIONS

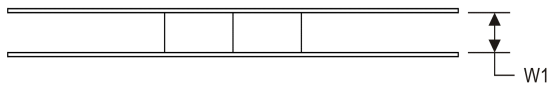
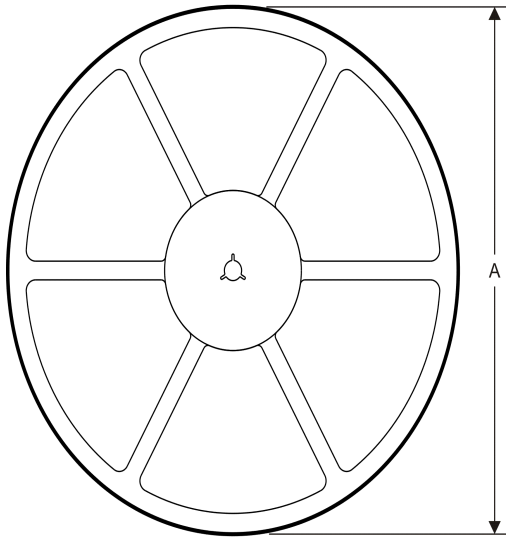

TAPE DIMENSIONS

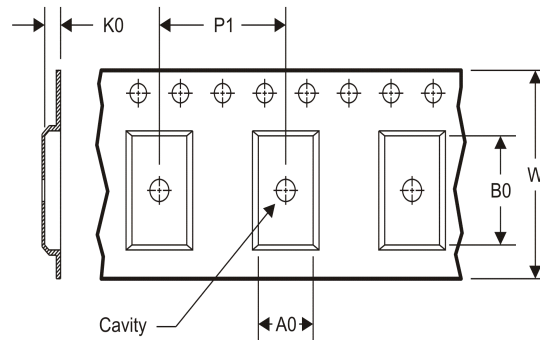

A0	Dimension designed to accommodate the component width
B0	Dimension designed to accommodate the component length
K0	Dimension designed to accommodate the component thickness
W	Overall width of the carrier tape
P1	Pitch between successive cavity centers

TAPE AND REEL INFORMATION

\*All dimensions are nominal

Device	Package Type	Package Drawing	Pins	SPQ	Reel Diameter (mm)	Reel Width W1 (mm)	A0 (mm)	B0 (mm)	K0 (mm)	P1 (mm)	W (mm)	Pin1 Quadrant
TPS65561RGTR	QFN	RGT	16	3000	330.0	12.4	3.3	3.3	1.1	8.0	12.0	Q2
TPS65561RGTT	QFN	RGT	16	250	180.0	12.4	3.3	3.3	1.1	8.0	12.0	Q2

**TAPE AND REEL BOX DIMENSIONS**

\*All dimensions are nominal

Device	Package Type	Package Drawing	Pins	SPQ	Length (mm)	Width (mm)	Height (mm)
TPS65561RGTR	QFN	RGT	16	3000	367.0	367.0	35.0
TPS65561RGTT	QFN	RGT	16	250	210.0	185.0	35.0

RGT (S-PVQFN-N16)

PLASTIC QUAD FLATPACK NO-LEAD

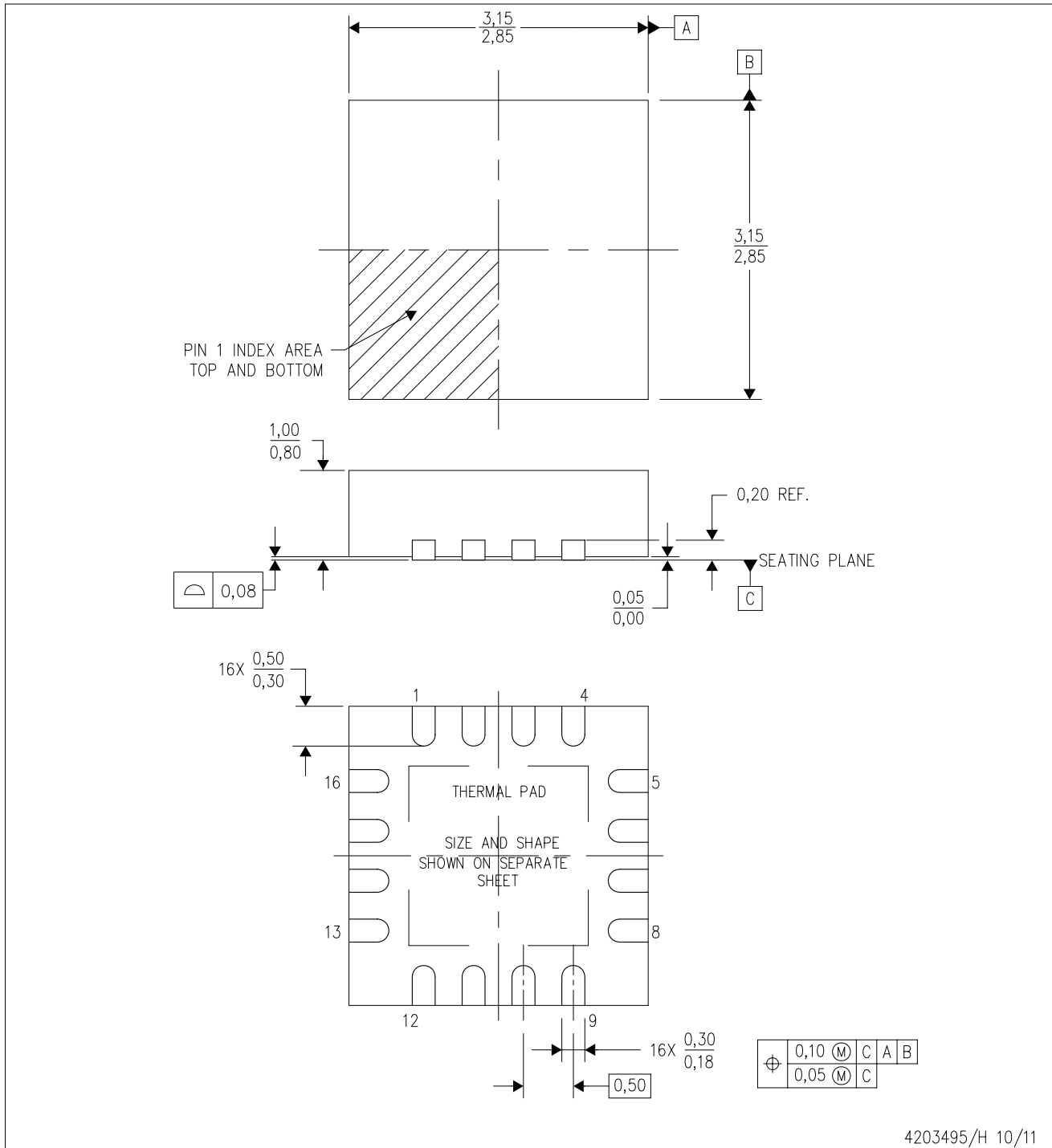

4203495/H 10/11

- NOTES:
- All linear dimensions are in millimeters. Dimensioning and tolerancing per ASME Y14.5M-1994.
  - This drawing is subject to change without notice.
  - Quad Flatpack, No-leads (QFN) package configuration.
  - The package thermal pad must be soldered to the board for thermal and mechanical performance.
  - See the additional figure in the Product Data Sheet for details regarding the exposed thermal pad features and dimensions.
  - Falls within JEDEC MO-220.

## THERMAL PAD MECHANICAL DATA

RGT (S-PVQFN-N16)

PLASTIC QUAD FLATPACK NO-LEAD

### THERMAL INFORMATION

This package incorporates an exposed thermal pad that is designed to be attached directly to an external heatsink. The thermal pad must be soldered directly to the printed circuit board (PCB). After soldering, the PCB can be used as a heatsink. In addition, through the use of thermal vias, the thermal pad can be attached directly to the appropriate copper plane shown in the electrical schematic for the device, or alternatively, can be attached to a special heatsink structure designed into the PCB. This design optimizes the heat transfer from the integrated circuit (IC).

For information on the Quad Flatpack No-Lead (QFN) package and its advantages, refer to Application Report, QFN/SON PCB Attachment, Texas Instruments Literature No. SLUA271. This document is available at [www.ti.com](http://www.ti.com).

The exposed thermal pad dimensions for this package are shown in the following illustration.

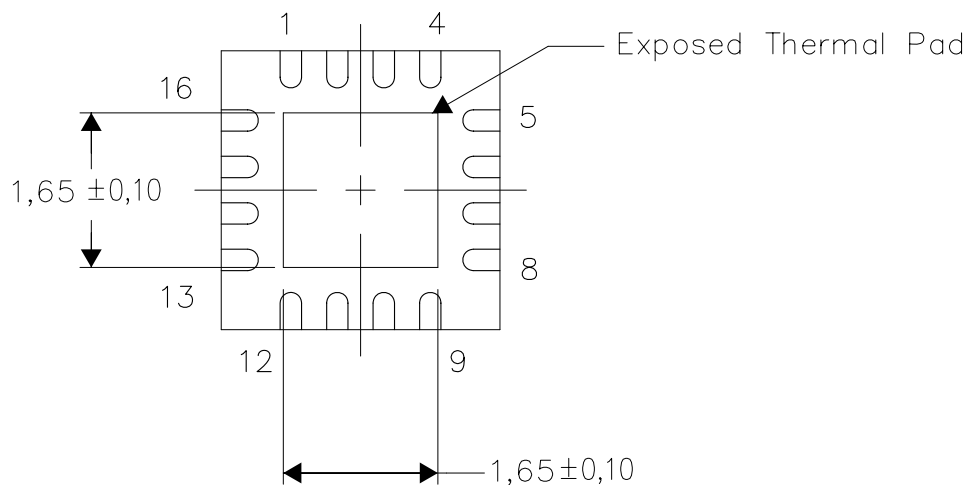

Bottom View

Exposed Thermal Pad Dimensions

4206349-7/Q 10/11

NOTE: All linear dimensions are in millimeters

## IMPORTANT NOTICE

Texas Instruments Incorporated and its subsidiaries (TI) reserve the right to make corrections, enhancements, improvements and other changes to its semiconductor products and services per JESD46C and to discontinue any product or service per JESD48B. Buyers should obtain the latest relevant information before placing orders and should verify that such information is current and complete. All semiconductor products (also referred to herein as "components") are sold subject to TI's terms and conditions of sale supplied at the time of order acknowledgment.

TI warrants performance of its components to the specifications applicable at the time of sale, in accordance with the warranty in TI's terms and conditions of sale of semiconductor products. Testing and other quality control techniques are used to the extent TI deems necessary to support this warranty. Except where mandated by applicable law, testing of all parameters of each component is not necessarily performed.

TI assumes no liability for applications assistance or the design of Buyers' products. Buyers are responsible for their products and applications using TI components. To minimize the risks associated with Buyers' products and applications, Buyers should provide adequate design and operating safeguards.

TI does not warrant or represent that any license, either express or implied, is granted under any patent right, copyright, mask work right, or other intellectual property right relating to any combination, machine, or process in which TI components or services are used. Information published by TI regarding third-party products or services does not constitute a license to use such products or services or a warranty or endorsement thereof. Use of such information may require a license from a third party under the patents or other intellectual property of the third party, or a license from TI under the patents or other intellectual property of TI.

Reproduction of significant portions of TI information in TI data books or data sheets is permissible only if reproduction is without alteration and is accompanied by all associated warranties, conditions, limitations, and notices. TI is not responsible or liable for such altered documentation. Information of third parties may be subject to additional restrictions.

Resale of TI components or services with statements different from or beyond the parameters stated by TI for that component or service voids all express and any implied warranties for the associated TI component or service and is an unfair and deceptive business practice. TI is not responsible or liable for any such statements.

Buyer acknowledges and agrees that it is solely responsible for compliance with all legal, regulatory and safety-related requirements concerning its products, and any use of TI components in its applications, notwithstanding any applications-related information or support that may be provided by TI. Buyer represents and agrees that it has all the necessary expertise to create and implement safeguards which anticipate dangerous consequences of failures, monitor failures and their consequences, lessen the likelihood of failures that might cause harm and take appropriate remedial actions. Buyer will fully indemnify TI and its representatives against any damages arising out of the use of any TI components in safety-critical applications.

In some cases, TI components may be promoted specifically to facilitate safety-related applications. With such components, TI's goal is to help enable customers to design and create their own end-product solutions that meet applicable functional safety standards and requirements. Nonetheless, such components are subject to these terms.

No TI components are authorized for use in FDA Class III (or similar life-critical medical equipment) unless authorized officers of the parties have executed a special agreement specifically governing such use.

Only those TI components which TI has specifically designated as military grade or "enhanced plastic" are designed and intended for use in military/aerospace applications or environments. Buyer acknowledges and agrees that any military or aerospace use of TI components which have **not** been so designated is solely at the Buyer's risk, and that Buyer is solely responsible for compliance with all legal and regulatory requirements in connection with such use.

TI has specifically designated certain components which meet ISO/TS16949 requirements, mainly for automotive use. Components which have not been so designated are neither designed nor intended for automotive use; and TI will not be responsible for any failure of such components to meet such requirements.

### Products

Audio	<a href="http://www.ti.com/audio">www.ti.com/audio</a>
Amplifiers	<a href="http://amplifier.ti.com">amplifier.ti.com</a>
Data Converters	<a href="http://dataconverter.ti.com">dataconverter.ti.com</a>
DLP® Products	<a href="http://www.dlp.com">www.dlp.com</a>
DSP	<a href="http://dsp.ti.com">dsp.ti.com</a>
Clocks and Timers	<a href="http://www.ti.com/clocks">www.ti.com/clocks</a>
Interface	<a href="http://interface.ti.com">interface.ti.com</a>
Logic	<a href="http://logic.ti.com">logic.ti.com</a>
Power Mgmt	<a href="http://power.ti.com">power.ti.com</a>
Microcontrollers	<a href="http://microcontroller.ti.com">microcontroller.ti.com</a>
RFID	<a href="http://www.ti-rfid.com">www.ti-rfid.com</a>
OMAP Mobile Processors	<a href="http://www.ti.com/omap">www.ti.com/omap</a>
Wireless Connectivity	<a href="http://www.ti.com/wirelessconnectivity">www.ti.com/wirelessconnectivity</a>

### Applications

Automotive and Transportation	<a href="http://www.ti.com/automotive">www.ti.com/automotive</a>
Communications and Telecom	<a href="http://www.ti.com/communications">www.ti.com/communications</a>
Computers and Peripherals	<a href="http://www.ti.com/computers">www.ti.com/computers</a>
Consumer Electronics	<a href="http://www.ti.com/consumer-apps">www.ti.com/consumer-apps</a>
Energy and Lighting	<a href="http://www.ti.com/energy">www.ti.com/energy</a>
Industrial	<a href="http://www.ti.com/industrial">www.ti.com/industrial</a>
Medical	<a href="http://www.ti.com/medical">www.ti.com/medical</a>
Security	<a href="http://www.ti.com/security">www.ti.com/security</a>
Space, Avionics and Defense	<a href="http://www.ti.com/space-avionics-defense">www.ti.com/space-avionics-defense</a>
Video and Imaging	<a href="http://www.ti.com/video">www.ti.com/video</a>

**TI E2E Community** [e2e.ti.com](http://e2e.ti.com)