

SWITCHED CAPACITOR MASK PROGRAMMABLE FILTER

- 8TH ORDER
- SELECTIVITY FACTOR : $Q = 35$
- GAIN AT CENTER FREQUENCY : 30dB (typ)
- LOW STOPBAND ATTENUATION : 70dB (typ)
- HIGH STOPBAND ATTENUATION : 70dB (typ)
- CLOCK TO CENTER FREQ. RATIO : 187.2
- CLOCK FREQUENCY RANGE : 4 TO 3800kHz
- CENTER FREQUENCY RANGE : 22Hz TO 20.3kHz

Note : For general characteristics, see TSG85XX specifications. For non standard quality level, consult SGS-THOMSON general ordering information.

DESCRIPTION

The TSG8551 is a HCMOS high selectivity band-pass filter.

PIN CONNECTIONS

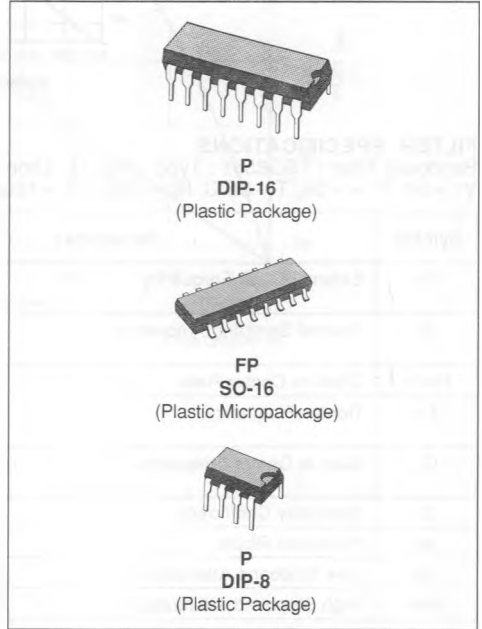
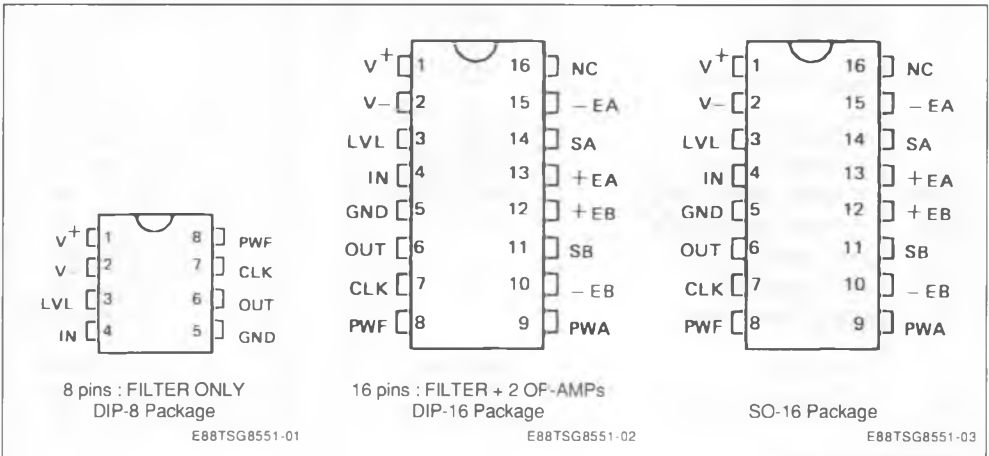

AMPLITUDE RESPONSE CURVE

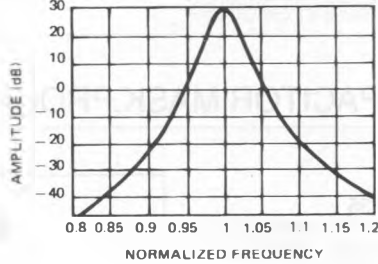

E88TSG8551-04

FILTER SPECIFICATIONS

Bandpass Filter : TSG8551 : Type : High Q ; Order : 8.

 $V^+ = 5V$, $V^- = -5V$, $T = 25^\circ C$, $R_L = 5k\Omega$, $C_L = 100pF$, $I_{PWF} = 100\mu A$

Symbol	Parameter		Typ.	Tested Limits	Unit
Fe	External Clock Frequency		4 3800(*)		kHz (min) kHz (max)
Fi	Internal Sampling Frequency		0.5 475(*)		kHz (min) kHz (max)
Fe/Fo	Clock to Center Ratio		187.2 \pm 1%		
Fo	Center Frequency		0.022 20.3(*)		kHz (min) kHz (max)
Go	Gain at Center Frequency		30	32 28	dB (min) dB (max)
Q	Selectivity Coefficient		35		
Ap	Passband Ripple				dB (max)
Als	Low Stopband Attenuation	$F < 0.8 F_o$	70	55	dB (min)
Ahs	High Stopband Attenuation	$F > 1.2 F_o$	70	55	dB (min)
Voff	Output DC Offset Voltage	LVL = 0V	± 100	± 200	mV (max)
LVL	DC Level Adjustment		± 70		mV (max)
LG	Level gain		- 3.3		
R _{PWF}	PWF Resistance		10 72		K Ω (min) K Ω (max)
I _{PWF}	Input Current on PWF		50 250		μA (min) μA (max)
I*	V* Supply Current	Fe = 100kHz I _{pwa} = 0 μA	3.8	5	mA (max)
I ⁻	V ⁻ Supply Current		3.8	5	mA (max)
PSRR*	V* Supply Rejection Ratio	Fe = 187.2kHz Fin = 1kHz	10**		dB
PSRR ⁻	V ⁻ Supply Rejection Ratio		19**		dB
R _{IN}	Input Resistance		3 M Ω		
C _{IN}	Input Capacitance		20 pF		
Vo	Output Voltage Swing		+ 3.5 - 4.5		Vp-p (max)
Vn	Output Noise	BW = 3Hz Fe = 187.2kHz Vin = 2Vrms	56**		μV rms
SNR	Signal to Noise Ratio		90**		dB

* I_{PWF} = 200 μA

** Value divided by the gain.

PHASE RESPONSE CURVE (in passband)

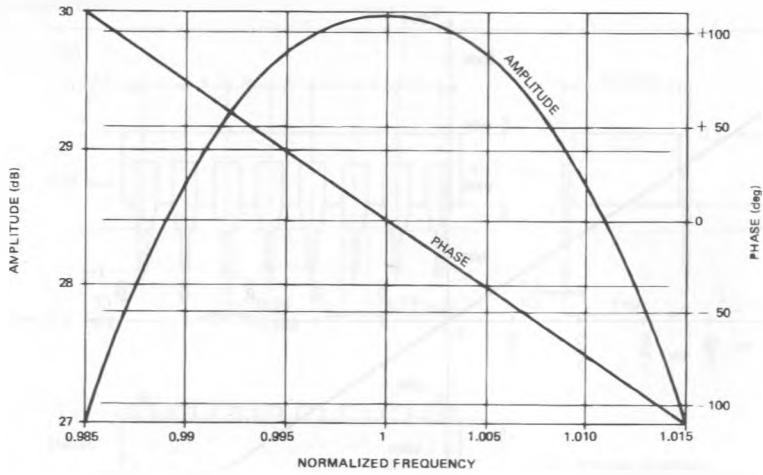

E88TSG8551-05

AMPLITUDE RESPONSE TEMPLATE (tested)

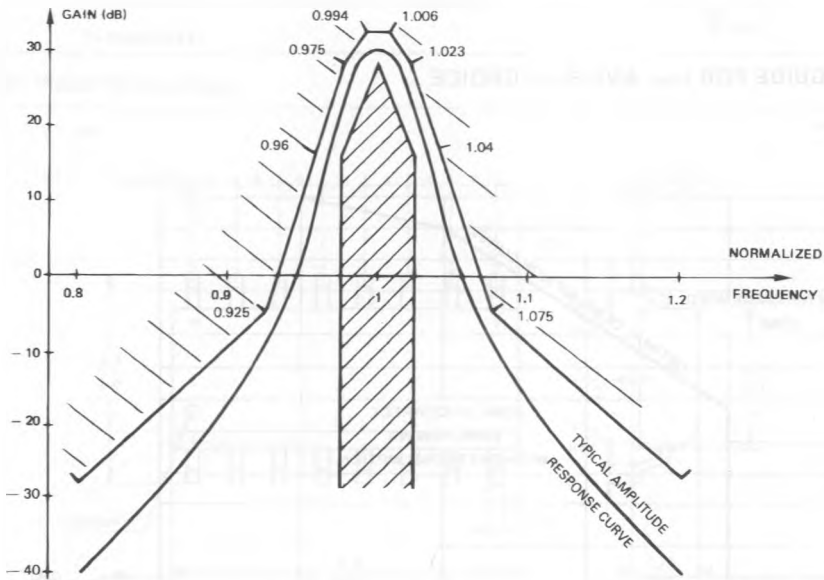

E88TSG8551-06

OUTPUT DC VOLTAGE ADJUSTMENT FROM LVL PIN

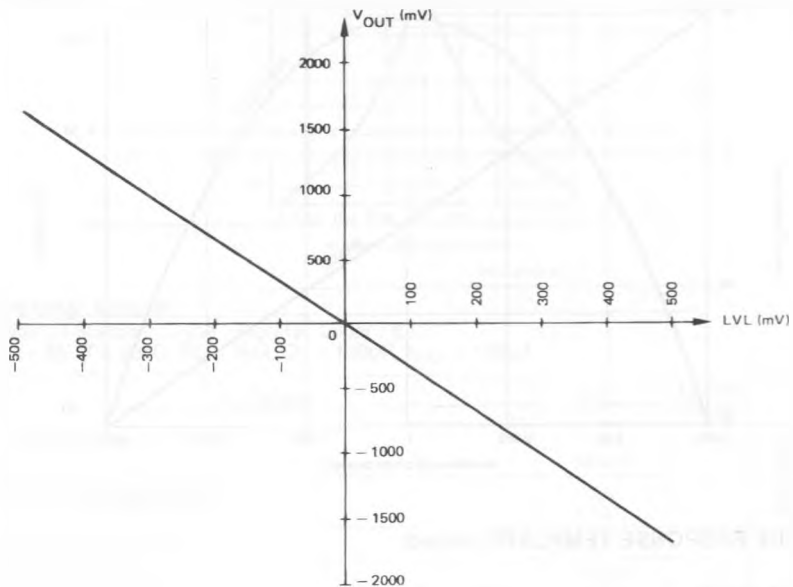

E88TSG8551-07

USER'S GUIDE FOR I_{PWF} AND R_{PWF} CHOICE

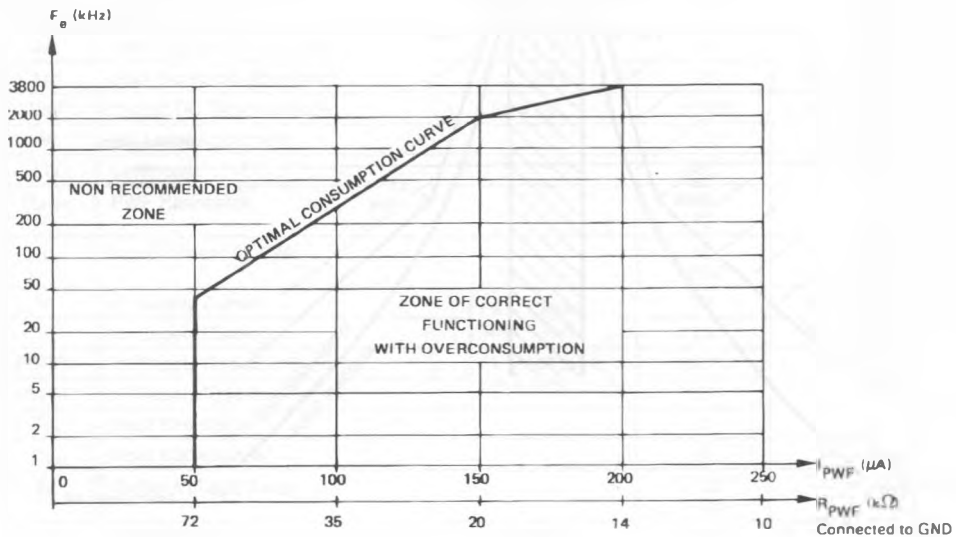

E88TSG8551-08

PACKAGE MECHANICAL DATA

16 PINS - Plastic Dip

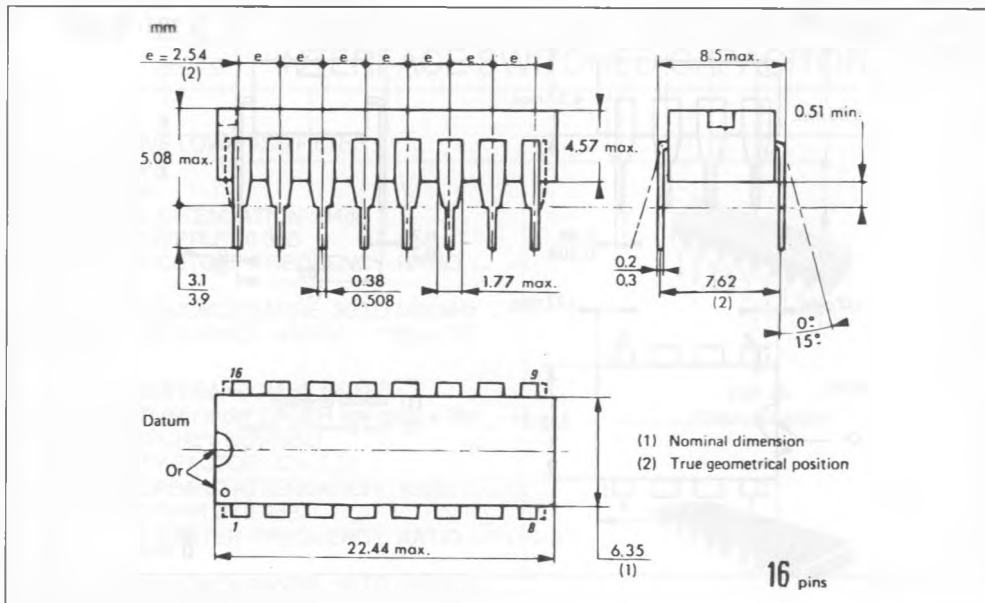

16 PINS - Plastic Micropackage

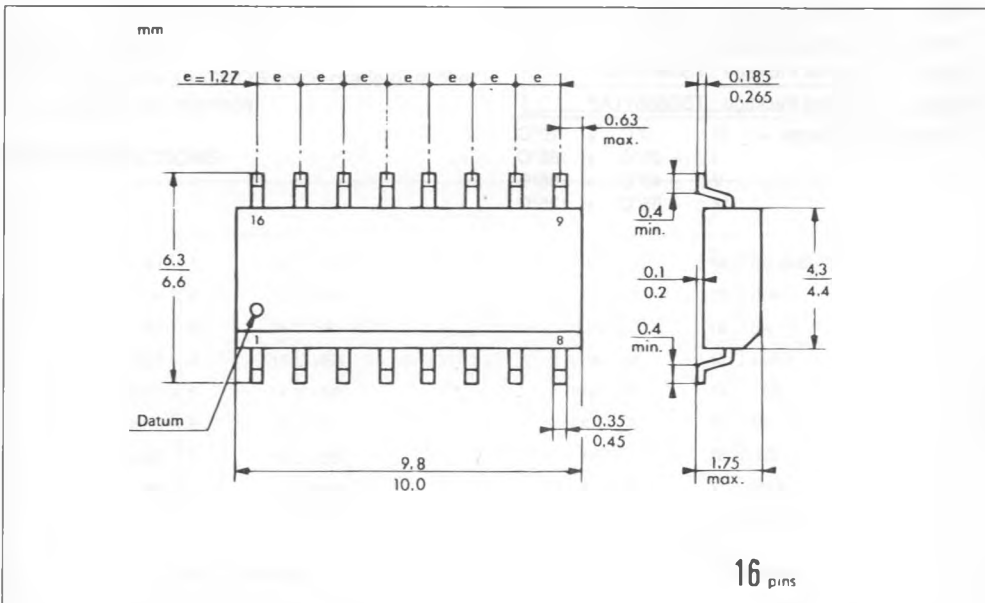

8 PINS - Plastic Dip

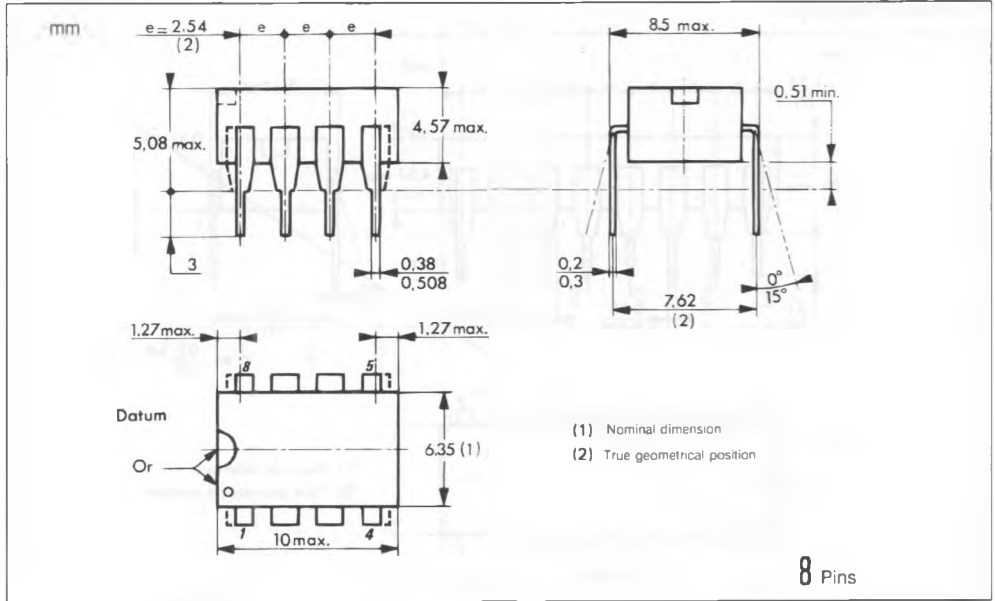

ORDER CODES

Plastic	16 Pins Package : TSG8551XP
Ceramic	16 Pins Package : TSG8551XC
Cerdip	16 Pins Package : TSG8551XJ
Plastic	8 Pins Package : TSG8551XP

X : Temperature Range = C : 0°C + 70°C
 I : - 25°C + 85°C
 V : - 40°C + 85°C
 M : - 55°C + 125°C