

CZT3090L
SURFACE MOUNT
LOW $V_{CE(SAT)}$
NPN SILICON POWER TRANSISTOR

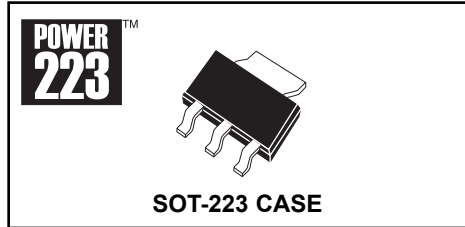

CentralTM

Semiconductor Corp.

DESCRIPTION:

The CENTRAL SEMICONDUCTOR CZT3090L is a Low $V_{CE(SAT)}$ NPN Transistor in a space saving Power SOT-223 surface mount package, designed for DC-DC converters for mobile systems and LAN cards, motor control, power management and strobe flash units.

MARKING CODE: FULL PART NUMBER

MAXIMUM RATINGS: ($T_A=25^{\circ}C$)

	SYMBOL		UNITS
Collector-Base Voltage	V_{CBO}	45	V
Collector-Emitter Voltage	V_{CEO}	15	V
Emitter-Base Voltage	V_{EBO}	6.0	V
Continuous Collector Current	I_C	3.0	A
Peak Pulse Current	I_{CM}	6.0	A
Power Dissipation	P_D	2.0	W
Operating and Storage			
Junction Temperature	T_J, T_{stg}	-65 to +150	$^{\circ}C$
Thermal Resistance	θ_{JA}	62.5	$^{\circ}C/W$

ELECTRICAL CHARACTERISTICS: ($T_A=25^{\circ}C$)

SYMBOL	TEST CONDITIONS	MIN	TYP	MAX	UNITS
I_{CBO}	$V_{CB}=20V$			100	nA
I_{EBO}	$V_{EB}=5.0V$			100	nA
BV_{CBO}	$I_C=10\mu A$	45			V
BV_{CEO}	$I_C=10mA$	15			V
BV_{EBO}	$I_E=10\mu A$	6.0			V
$V_{CE(SAT)}$	$I_C=100mA, I_B=1.0mA$		30	50	mV
$V_{CE(SAT)}$	$I_C=1.0A, I_B=20mA$		60	150	mV
$V_{CE(SAT)}$	$I_C=2.0A, I_B=200mA$		85	200	mV
$V_{CE(SAT)}$	$I_C=3.0A, I_B=60mA$		145	300	mV
h_{FE}	$V_{CE}=2.0V, I_C=500mA$	200			
h_{FE}	$V_{CE}=2.0V, I_C=1.0A$	200			
h_{FE}	$V_{CE}=2.0V, I_C=3.0A$	175			
C_{ob}	$V_{CB}=10V, f=1.0MHz$			100	pF
f_T	$V_{CE}=10V, I_C=500mA$	100			MHz

R1 (14-November 2002)

SOT-223 CASE - MECHANICAL OUTLINE

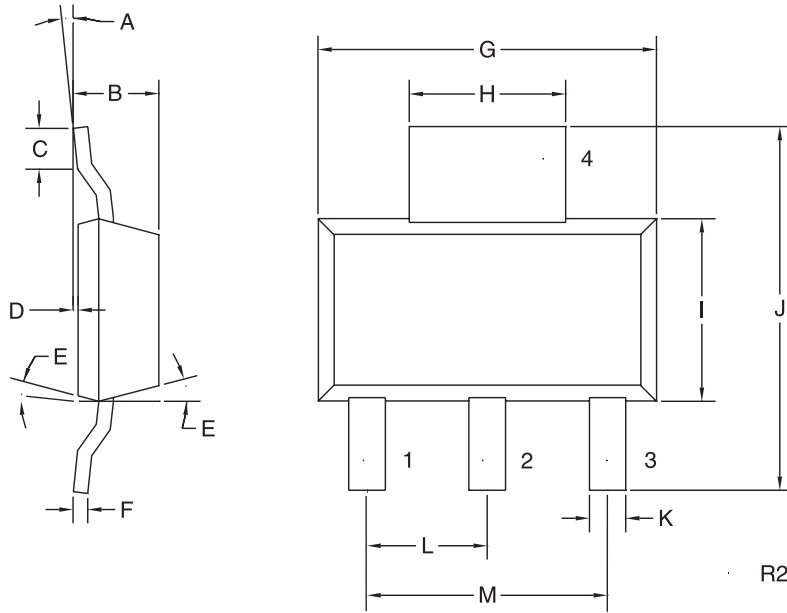

LEAD CODE:

- 1) BASE
- 2) COLLECTOR
- 3) EMITTER
- 4) COLLECTOR

**MARKING CODE:
FULL PART NUMBER**

SYMBOL	DIMENSIONS			
	INCHES		MILLIMETERS	
	MIN	MAX	MIN	MAX
A	0°	7°	0°	7°
B	0.063	0.067	1.60	1.70
C	0.022		0.55	
D	0.001	0.004	0.03	0.10
E	15°		15°	
F	0.009	0.013	0.23	0.33
G	0.248	0.264	6.30	6.71
H	0.114	0.122	2.90	3.10
I	0.130	0.146	3.30	3.71
J	0.264	0.287	6.71	7.29
K	0.024	0.031	0.61	0.79
L	0.091		2.31	
M	0.181		4.60	

SOT-223 (REV: R2)

R1 (14-November 2002)