

CZTA14 NPN
CZTA64 PNP

SILICON COMPLEMENTARY
DARLINGTON TRANSISTORS

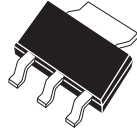

SOT-223 CASE

CentralTM
Semiconductor Corp.

DESCRIPTION:

The CENTRAL SEMICONDUCTOR CZTA14, CZTA64 types are complementary silicon Darlington transistors manufactured by the epitaxial planar process, epoxy molded in a surface mount package, designed for applications requiring extremely high gain.

MARKING CODE: FULL PART NUMBER

MAXIMUM RATINGS: ($T_A=25^\circ\text{C}$)

	SYMBOL		UNITS
Collector-Base Voltage	V_{CB0}	30	V
Collector-Emitter Voltage	V_{CEO}	30	V
Emitter-Base Voltage	V_{EBO}	10	V
Continuous Collector Current	I_C	1.0	A
Power Dissipation	P_D	2.0	W
Operating and Storage			
Junction Temperature	T_J, T_{stg}	-65 to +150	$^\circ\text{C}$
Thermal Resistance	θ_{JA}	62.5	$^\circ\text{C/W}$

ELECTRICAL CHARACTERISTICS: ($T_A=25^\circ\text{C}$ unless otherwise noted)

SYMBOL	TEST CONDITIONS	MIN	MAX	UNITS
I_{CBO}	$V_{CB}=30\text{V}$		100	nA
I_{EBO}	$V_{EB}=10\text{V}$		100	nA
BV_{CES}	$I_C=100\mu\text{A}$	30		V
$V_{CE(SAT)}$	$I_C=100\text{mA}, I_B=0.1\text{mA}$		1.5	V
$V_{BE(ON)}$	$V_{CE}=5.0\text{V}, I_C=100\text{mA}$		2.0	V
h_{FE}	$V_{CE}=5.0\text{V}, I_C=10\text{mA}$	10,000		
h_{FE}	$V_{CE}=5.0\text{V}, I_C=100\text{mA}$	20,000		
f_T	$V_{CE}=5.0\text{V}, I_C=10\text{mA}, f=100\text{MHz}$	125		MHz

**SILICON COMPLEMENTARY
DARLINGTON TRANSISTORS**

SOT-223 CASE - MECHANICAL OUTLINE

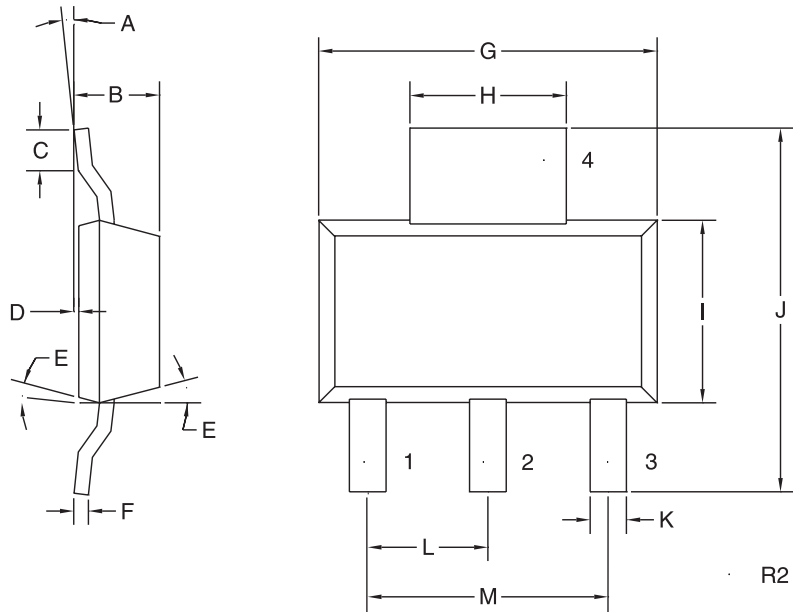

LEAD CODE:

- 1) BASE
- 2) COLLECTOR
- 3) EMITTER
- 4) COLLECTOR

MARKING CODE:

FULL PART NUMBER

SYMBOL	DIMENSIONS			
	INCHES		MILLIMETERS	
	MIN	MAX	MIN	MAX
A	0°	7°	0°	7°
B	0.063	0.067	1.60	1.70
C	0.022		0.55	
D	0.001	0.004	0.03	0.10
E	15°		15°	
F	0.009	0.013	0.23	0.33
G	0.248	0.264	6.30	6.71
H	0.114	0.122	2.90	3.10
I	0.130	0.146	3.30	3.71
J	0.264	0.287	6.71	7.29
K	0.024	0.031	0.61	0.79
L	0.091		2.31	
M	0.181		4.60	

SOT-223 (REV: R2)

R1 (26-September 2002)