

General purpose (dual digital transistors)

UMA4N / UMB4N / UMB8N / FMA4A / IMB4A / IMB8A

●Features

1) Two DTA114T chips in a UMT or SMT package.

●Circuit diagrams

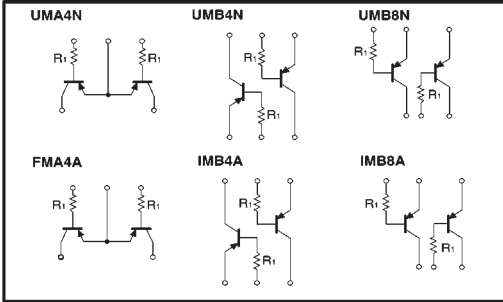

●Absolute maximum ratings (Ta=25°C)

Parameter	Symbol	Limits	Unit
Collector-base voltage	V _{CB0}	-50	V
Collector-emitter voltage	V _{CE0}	-50	V
Emitter-base voltage	V _{EB0}	-5	V
Collector current	I _c	-100	mA
Power dissipation	P _d	150 (TOTAL) 300 (TOTAL)	mW *1 *2
Junction temperature	T _j	150	°C
Storage temperature	T _{stg}	-55~+150	°C

*1 120mW per element must not be exceeded.
*2 200mW per element must not be exceeded.

●Package, marking, and packaging specifications

Part No.	UMA4N	UMB4N	UMB8N	FMA4A	IMB4A	IMB8A
Package	UMT5	UMT6	UMT6	SMT5	SMT6	SMT6
Marking	A4	B4	B8	A4	B4	B8
Code	TR	TN	TR	T148	T110	T108
Basic ordering unit (pieces)	3000	3000	3000	3000	3000	3000

●Electrical characteristics (Ta=25°C)

Parameter	Symbol	Min.	Typ.	Max.	Unit	Conditions
Collector-base breakdown voltage	BV _{CB0}	-50	—	—	V	I _c =-50 μA
Collector-emitter breakdown voltage	BV _{CE0}	-50	—	—	V	I _c =-1mA
Emitter-base breakdown voltage	BV _{EB0}	-5	—	—	V	I _e =-50 μA
Collector cutoff current	I _{CB0}	—	—	-0.5	μA	V _{CB} =-50V
Emitter cutoff current	I _{EB0}	—	—	-0.5	μA	V _{EB} =-4V
Collector-emitter saturation voltage	V _{CE(sat)}	—	—	-0.3	V	I _c /I _e =-10mA/-1mA
DC current transfer ratio	h _{FE}	100	250	600	—	V _{CE} =-5V, I _c =-1mA
Transition frequency	f _r	—	250	—	MHz	V _{CE} =-10V, I _e =5mA, f=100MHz *
Input resistance	R _i	7	10	13	kΩ	—

* Transition frequency of the device.

(96-448-A114T)

General purpose (dual digital transistors)

UMG4N / UMG7N / UMH4N / UMH8N / FMG4A / FMG7A / IMH4A / IMH8A

●Features

1) Two DTC114T chips in a UMT or SMT package.

●Circuit diagrams

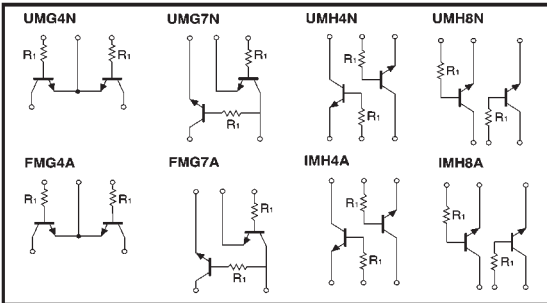

●Absolute maximum ratings (Ta=25°C)

Parameter	Symbol	Limits	Unit
Collector-base voltage	V _{CB0}	50	V
Collector-emitter voltage	V _{CE0}	50	V
Emitter-base voltage	V _{EB0}	5	V
Collector current	I _c	100	mA
Power dissipation	P _d	150 (TOTAL) 300 (TOTAL)	mW *1 *2
Junction temperature	T _j	150	°C
Storage temperature	T _{stg}	-55~+150	°C

*1 120mW per element must not be exceeded.
*2 200mW per element must not be exceeded.

●Package, marking, and packaging specifications

Part No.	UMG4N	UMG7N	UMH4N	UMH8N	FMG4A	FMG7A	IMH4A	IMH8A
Package	UMT5	UMT5	UMT6	UMT6	SMT5	SMT5	SMT6	SMT6
Marking	G4	G7	H4	H8	G4	G7	H4	H8
Code	TR	TR	TN	TR	T148	T148	T110	T108
Basic ordering unit (pieces)	3000	3000	3000	3000	3000	3000	3000	3000

●Electrical characteristics (Ta=25°C)

Parameter	Symbol	Min.	Typ.	Max.	Unit	Conditions
Collector-base breakdown voltage	BV _{CB0}	50	—	—	V	I _c =50 μA
Collector-emitter breakdown voltage	BV _{CE0}	50	—	—	V	I _c =1mA
Emitter-base breakdown voltage	BV _{EB0}	5	—	—	V	I _e =50 μA
Collector cutoff current	I _{CB0}	—	—	0.5	μA	V _{CB} =50V
Emitter cutoff current	I _{EB0}	—	—	0.5	μA	V _{EB} =4V
Collector-emitter saturation voltage	V _{CE(sat)}	—	—	0.3	V	I _c /I _e =10mA/1mA
DC current transfer ratio	h _{FE}	100	250	600	—	V _{CE} =5V, I _c =1mA
Transition frequency	f _r	—	250	—	MHz	V _{CE} =10V, I _e =-5mA, f=100MHz *
Input resistance	R _i	7	10	13	kΩ	—

* Transition frequency of the device.

(96-411-C114T)