

Absolute Maximum Ratings		Values	Units
Symbol	Conditions ¹⁾		
V_{CES}		1700	V
V_{CGR}	$R_{GE} = 20 \text{ k}\Omega$	1700	V
$I_C; I_{CN}$	$T_{case} = 25/80 \text{ }^\circ\text{C}$	320 / 230	A
I_{CM}	$T_{case} = 25/80 \text{ }^\circ\text{C}; t_p = 1 \text{ ms}$	640 / 460	A
V_{GES}		± 20	V
P_{tot}	per IGBT, $T_{case} = 25 \text{ }^\circ\text{C}$	1800	W
$T_j, (T_{stg})$		-40 ... +150 (125)	$^\circ\text{C}$
V_{isol}	AC, 1 min. ⁴⁾	3400	V
humidity	IEC 60721-3-3	class 3K7/IE32	
climate	IEC 68 T.1	40/125/56	
Inverse Diode ⁸⁾			
$I_F = -I_C$	$T_{case} = 25/80 \text{ }^\circ\text{C}$	390 / 260	A
$I_{FM} = -I_{CM}$	$T_{case} = 25/80 \text{ }^\circ\text{C}; t_p = 1 \text{ ms}$	640 / 460	A
I_{FSM}	$t_p = 10 \text{ ms}; \text{sin.}; T_j = 150 \text{ }^\circ\text{C}$	2200	A
I^2t	$t_p = 10 \text{ ms}; T_j = 150 \text{ }^\circ\text{C}$	24200	A^2s

SEMITRANS® M Low Loss IGBT Modules

SKM 300 GB 174 D

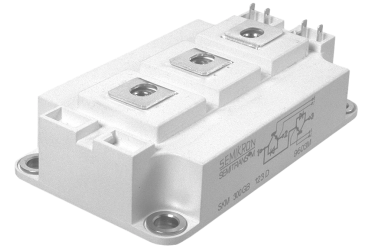

SEMITRANS 3

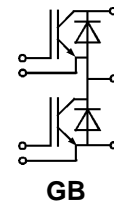

Features

- N channel, homogeneous Silicon structure (NPT- Non punch-through IGBT)
- Low inductance case
- High short circuit capability, self limiting
- Fast & soft inverse CAL diodes ⁸⁾
- Without hard mould
- Isolated copper baseplate using DCB Direct Copper Bonding
- Large clearance (13 mm) and creepage distances (20 mm)

Typical Applications

- AC inverter drives on mains 575 - 750 V_{AC}
- DC bus voltage 750 - 1200 V_{DC}
- Public transport (auxiliary syst.)
- Switching (not for linear use)

Characteristics		min.	typ.	max.	Units
Symbol	Conditions ¹⁾				
$V_{(BR)CES}$	$V_{GE} = 0, I_C = 6 \text{ mA}$	$\geq V_{CES}$	-	-	V
$V_{GE(th)}$	$V_{GE} = V_{CE}, I_C = 9 \text{ mA}$	4,5	5,5	6,5	V
I_{CES}	$V_{GE} = 0 \left. \begin{array}{l} T_j = 25 \text{ }^\circ\text{C} \\ T_j = 125 \text{ }^\circ\text{C} \end{array} \right\}$	-	0,1	1	mA
		-	8	-	mA
I_{GES}	$V_{GE} = 20 \text{ V}, V_{CE} = 0$	-	-	0,2	μA
V_{CESat}	$I_C = 200 \text{ A} \left. \begin{array}{l} V_{GE} = 15 \text{ V}; \\ T_j = 25 (125) \text{ }^\circ\text{C} \end{array} \right\}$	-	2,8(3,25)	3,3(3,8)	V
		-	3,3(3,8)	-	V
g_{fs}	$V_{CE} = 20 \text{ V}, I_C = 200 \text{ A}$	80	110	-	S
C_{CHC}	per IGBT	-	-	0,7	nF
C_{ies}	$V_{GE} = 0$	-	14	-	nF
C_{oes}	$V_{CE} = 25 \text{ V}$	-	2,0	-	nF
C_{res}	$f = 1 \text{ MHz}$	-	0,6	-	nF
L_{CE}		-	-	20	nH
$t_{d(on)}$	$V_{CC} = 1200 \text{ V}$	-	100	-	ns
t_r	$V_{GE} = -15 \text{ V} / +15 \text{ V} \text{ } ^3)$	-	100	-	ns
$t_{d(off)}$	$I_C = 200 \text{ A}, \text{ind. load}$	-	900	-	ns
t_f	$R_{Gon} = R_{Goff} = 6,8 \text{ } \Omega$	-	150	-	ns
E_{on}	$T_j = 125 \text{ }^\circ\text{C} (V_{CC} = 900 \text{ V}/1200 \text{ V})$	-	90/125	-	mWs
E_{off}	$L_S = 60 \text{ nH} (V_{CC} = 900 \text{ V}/1200 \text{ V})$	-	65/95	-	mWs
Inverse Diode ⁸⁾					
$V_F = V_{EC}$	$I_F = 200 \text{ A} \left. \begin{array}{l} V_{GE} = 0 \text{ V}; \\ T_j = 25 (125) \text{ }^\circ\text{C} \end{array} \right\}$	-	2,15(1,9)	2,4(2,25)	V
$V_F = V_{EC}$		$I_F = 300 \text{ A}$	-	2,4(2,2)	2,75(2,5)
V_{TO}	$T_j = 125 \text{ }^\circ\text{C}$	-	1,3	1,5	V
r_t	$T_j = 125 \text{ }^\circ\text{C}$	-	3	4	$\text{m}\Omega$
I_{RRM}	$I_F = 200 \text{ A}; T_j = 25 (125) \text{ }^\circ\text{C} \text{ } ^2)$	-	100(200)	-	A
Q_{rr}	$I_F = 200 \text{ A}; T_j = 25 (125) \text{ }^\circ\text{C} \text{ } ^2)$	-	24(50)	-	μC
E_{rr}	$I_F = 200 \text{ A}; T_j = 25 (125) \text{ }^\circ\text{C} \text{ } ^2)$	-	10(18)	-	mWs
Thermal characteristics					
R_{thjc}	per IGBT	-	-	0,07	$^\circ\text{C}/\text{W}$
R_{thjc}	per diode D	-	-	0,125	$^\circ\text{C}/\text{W}$
R_{thch}	per module (50 μm grease)	-	-	0,038	$^\circ\text{C}/\text{W}$

¹⁾ $T_{case} = 25 \text{ }^\circ\text{C}$, unless otherwise specified

²⁾ $I_F = -I_C, V_R = 1200 \text{ V}, -di_F/dt = 2000 \text{ A}/\mu\text{s}, V_{GE} = 0 \text{ V}$

³⁾ Use $V_{GEOff} = -5 \dots -15 \text{ V}$

⁴⁾ Option $V_{isol} = 4000\text{V}/1 \text{ min}$ add suffix „H4“ - on request

⁸⁾ CAL = Controlled Axial Lifetime Technology

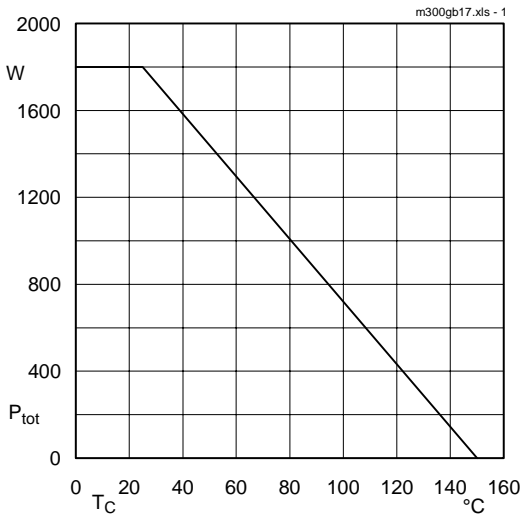

Fig. 1 Rated power dissipation $P_{tot} = f(T_C)$

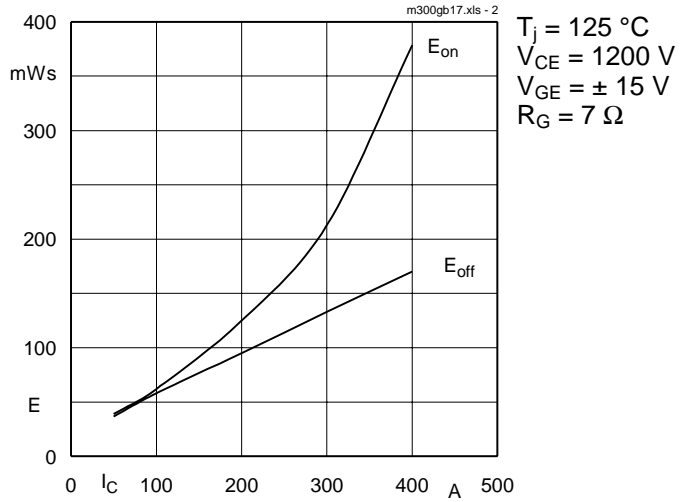

Fig. 2 Turn-on /-off energy $= f(I_C)$

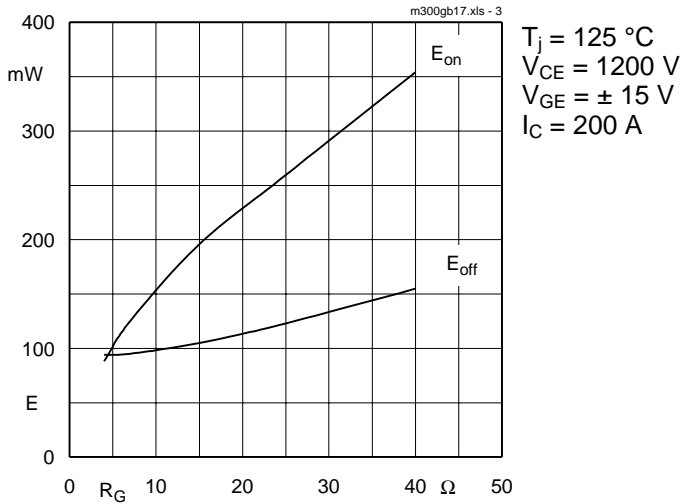

Fig. 3 Turn-on /-off energy $= f(R_G)$

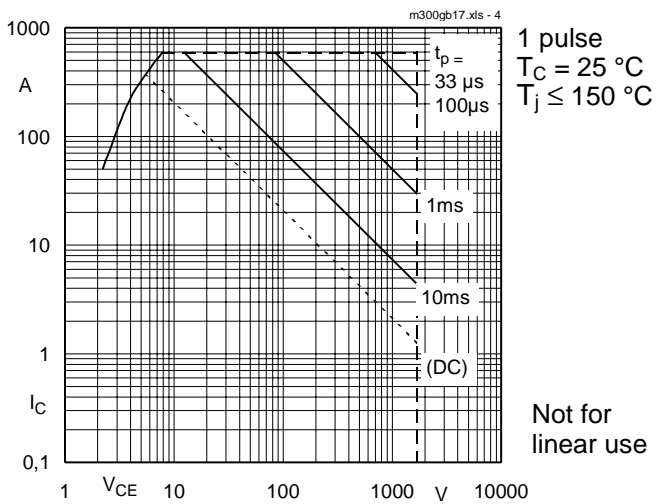

Fig. 4 Maximum safe operating area (SOA) $I_C = f(V_{CE})$

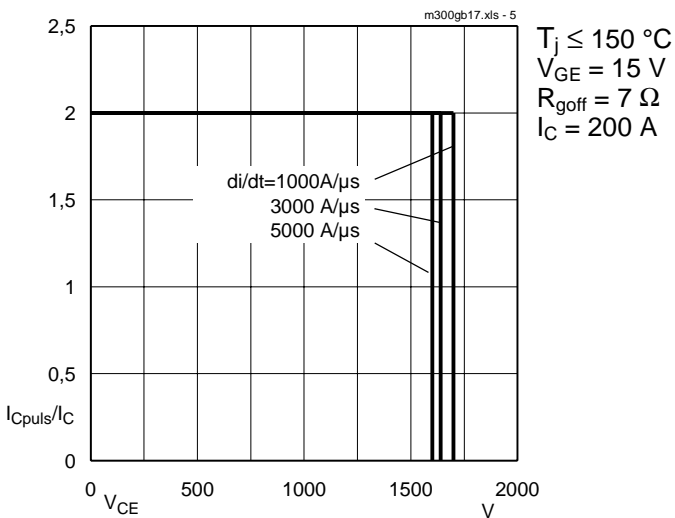

Fig. 5 Turn-off safe operating area (RBSOA)

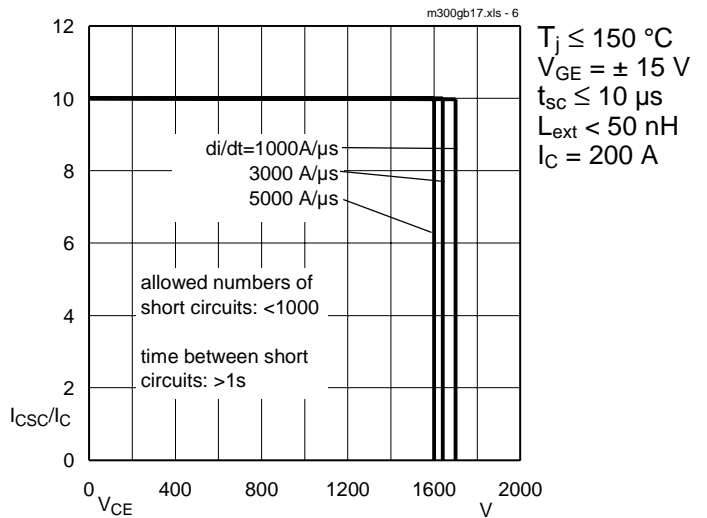

Fig. 6 Safe operating area at short circuit $I_C = f(V_{CE})$

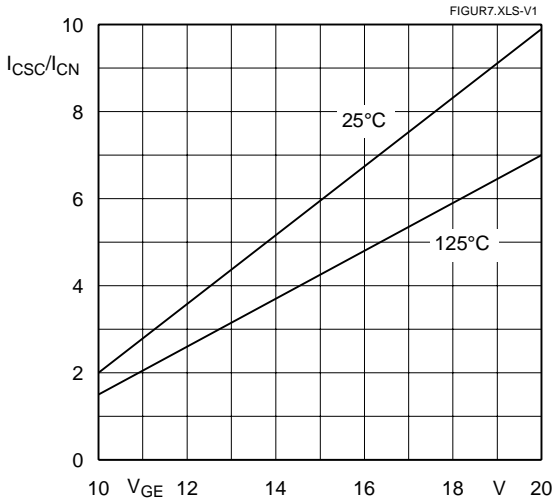

Fig. 7 Short circuit current vs. turn-on gate voltage

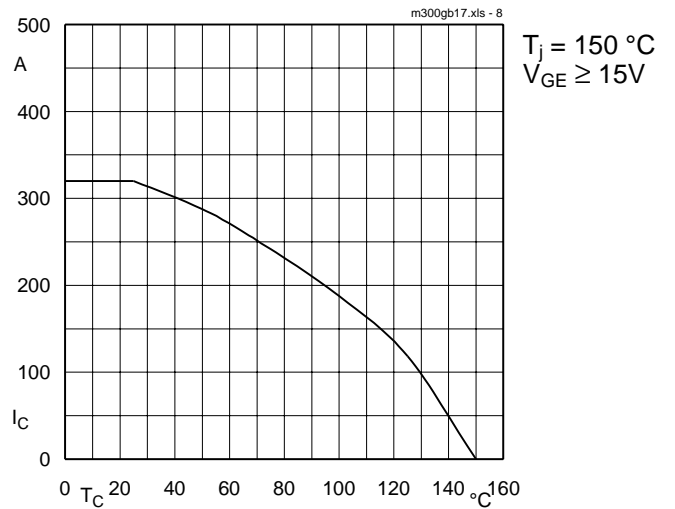

Fig. 8 Rated current vs. temperature $I_C = f(T_C)$

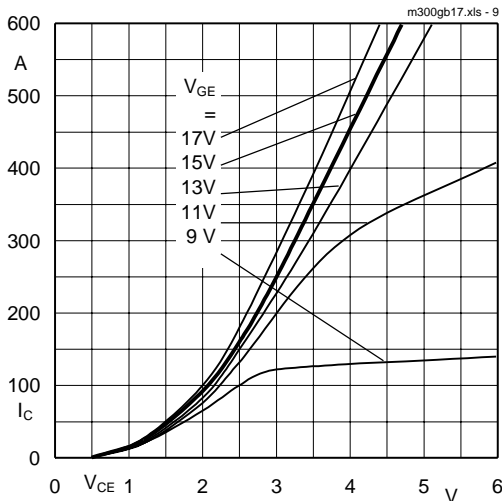

Fig. 9 Typ. output characteristic, $t_p = 250 \mu s$; $T_j = 25 \text{ }^\circ\text{C}$

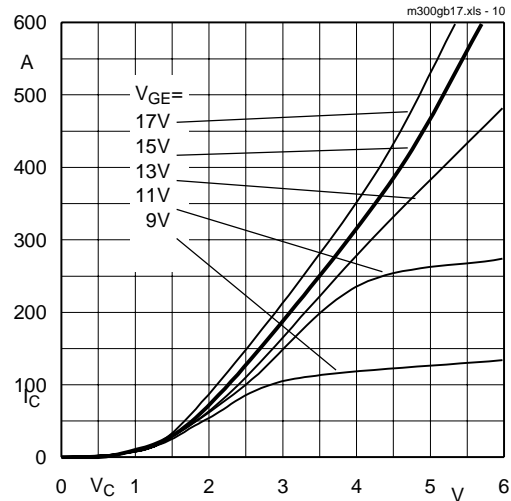

Fig. 10 Typ. output characteristic, $t_p = 250 \mu s$; $T_j = 125 \text{ }^\circ\text{C}$

$$P_{cond(t)} = V_{CEsat(t)} \cdot I_{C(t)}$$

$$V_{CEsat(t)} = V_{CE(TO)(T_j)} + r_{CE(T_j)} \cdot I_{C(t)}$$

$$V_{CE(TO)(T_j)} \leq 1,5 + 0,001 (T_j - 25) \text{ [V]}$$

$$\text{typ: } r_{CE(T_j)} = 0,0065 + 0,000018 (T_j - 25) \text{ [\Omega]}$$

$$\text{max: } r_{CE(T_j)} \leq 0,0088 + 0,000023 (T_j - 25) \text{ [\Omega]}$$

$$\text{valid for } V_{GE} \leq +15 \frac{+2}{-1} \text{ [V]; } I_C \geq 0,3 I_{Cnom}$$

Fig. 11 Typ. saturation characteristic (IGBT)
Calculation elements and equations

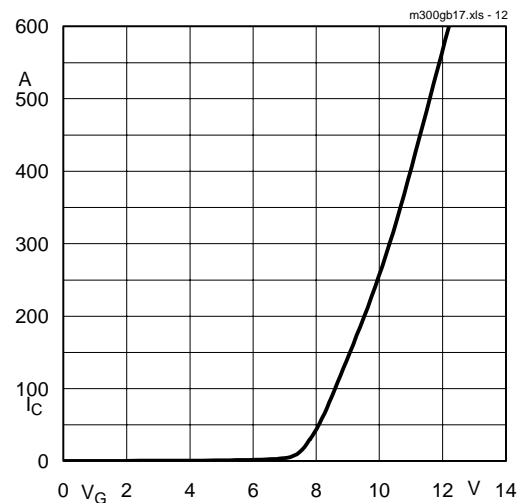

Fig. 12 Typ. transfer characteristic, $t_p = 250 \mu s$; $V_{CE} = 20 \text{ V}$

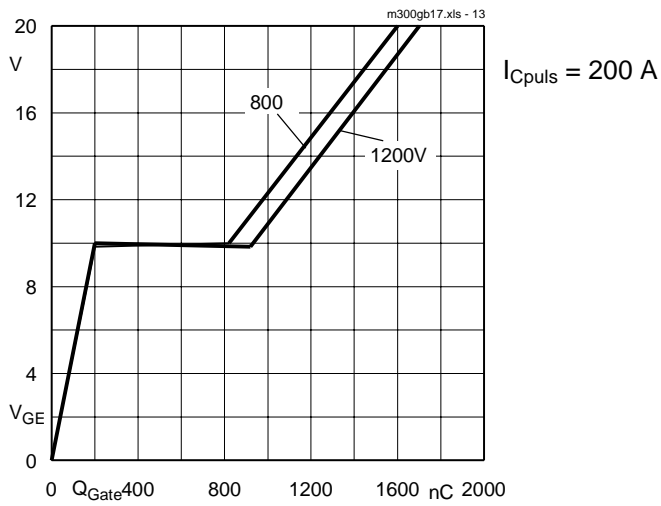

Fig. 13 Typ. gate charge characteristic

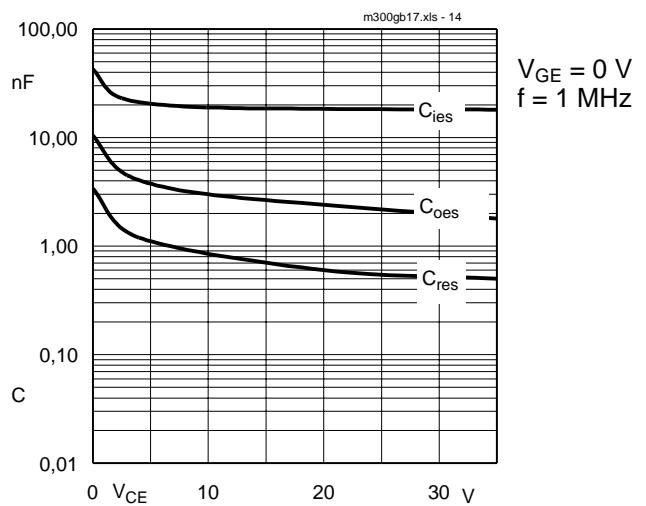

Fig. 14 Typ. capacitances vs. V_{CE}

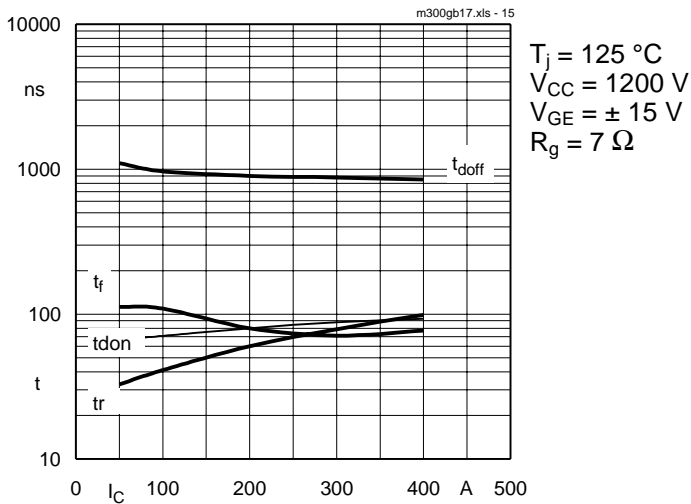

Fig. 15 Typ. switching times vs. I_C

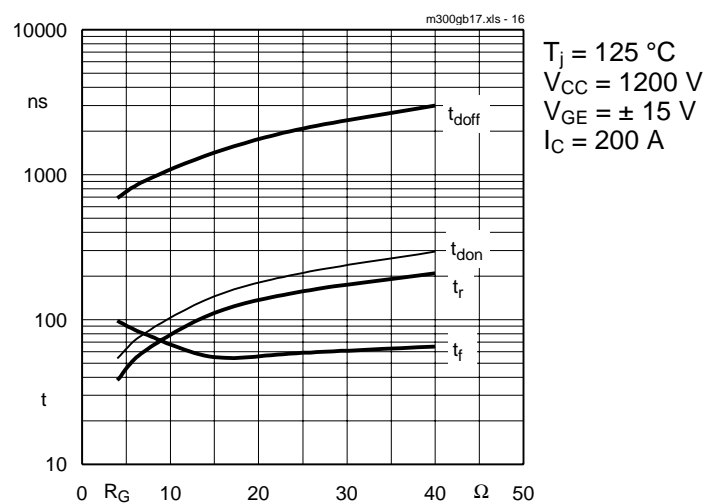

Fig. 16 Typ. switching times vs. gate resistor R_G

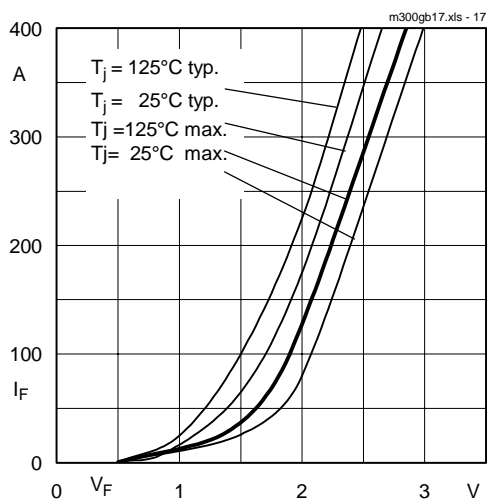

Fig. 17 Typ. CAL diode forward characteristic

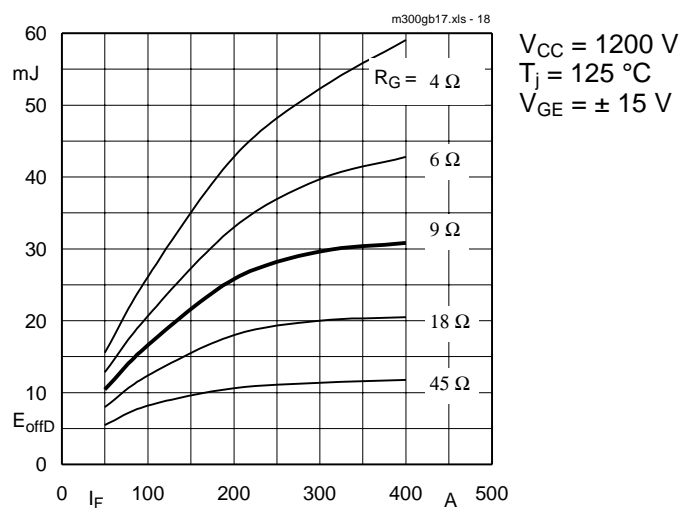

Fig. 18 Diode turn-off energy dissipation per pulse

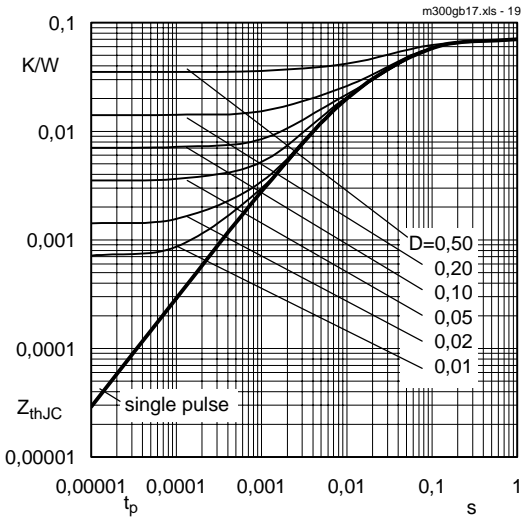

Fig. 19 Transient thermal impedance of IGBT
 $Z_{thJC} = f(t_p)$; $D = t_p / t_c = t_p \cdot f$

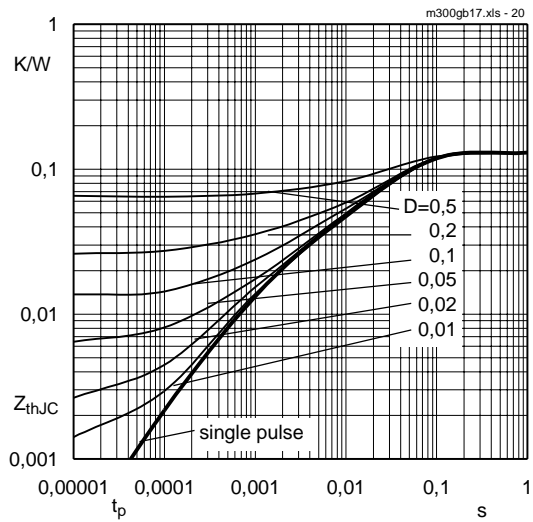

Fig. 20 Transient thermal impedance of inverse CAL diodes
 $Z_{thJC} = f(t_p)$; $D = t_p / t_c = t_p \cdot f$

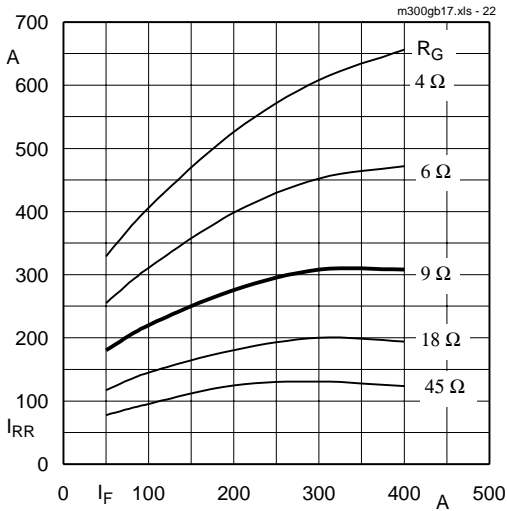

Fig. 22 Typ. CAL diode peak reverse recovery current $I_{RR} = f(I_F; R_G)$

$V_{CC} = 1200\text{ V}$
 $T_j = 125\text{ }^\circ\text{C}$
 $V_{GE} = \pm 15\text{ V}$

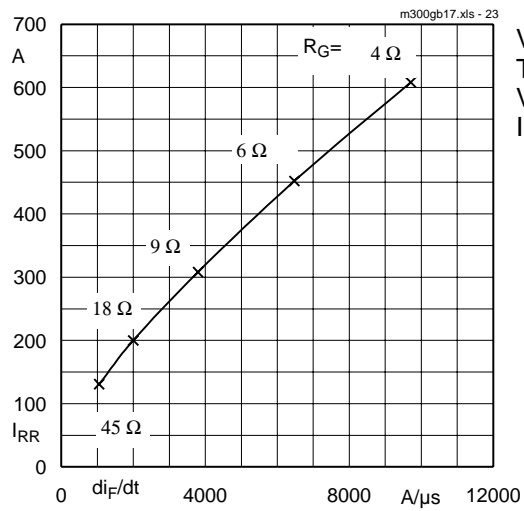

Fig. 23 Typ. CAL diode peak reverse recovery current $I_{RR} = f(di/dt)$

$V_{CC} = 1200\text{ V}$
 $T_j = 125\text{ }^\circ\text{C}$
 $V_{GE} = \pm 15\text{ V}$
 $I_F = 200\text{ A}$

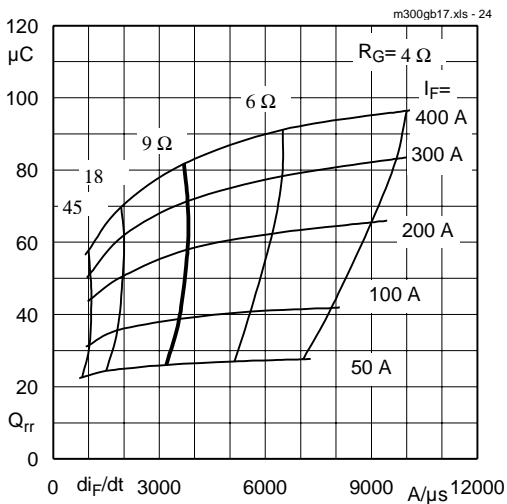

Fig. 24 Typ. CAL diode recovered charge

$V_{CC} = 1200\text{ V}$
 $T_j = 125\text{ }^\circ\text{C}$
 $V_{GE} = \pm 15\text{ V}$

SEMITRANS 3

Case D 56

UL Recognized
File no. E 63 532

SKM 200 GB 174 D

SKM 300 GB 174 D

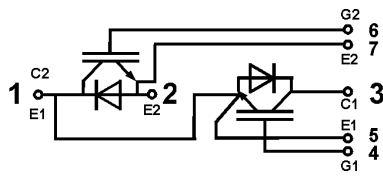
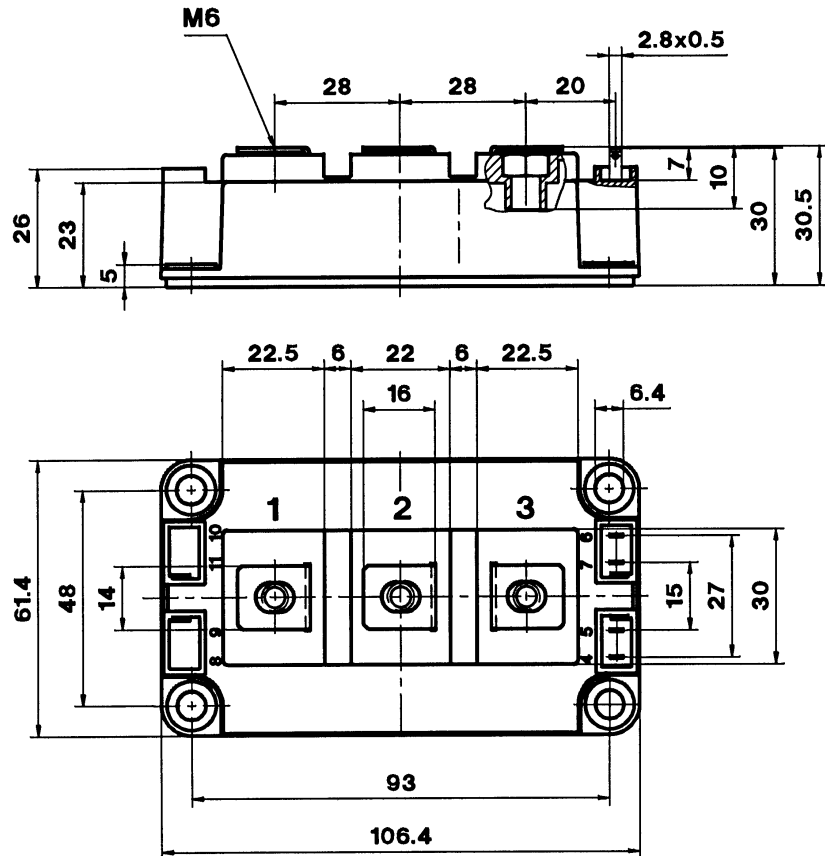

Dimensions in mm

Case outline and circuit diagram

Mechanical Data		Values			Units
Symbol	Conditions	min.	typ.	max.	
M ₁	to heatsink, SI Units	3	–	5	Nm
	to heatsink, US Units	27	–	44	lb.in.
M ₂	for terminals, SI Units	2,5	–	5	Nm
	for terminals, US Units	22	–	44	lb.in.
a		–	–	5x9,81	m/s ²
w		–	–	325	g

This is an electrostatic discharge sensitive device (ESDS). Please observe the international standard IEC 747-1, Chapter IX.

Twelve devices are supplied in one SEMIBOX D without mounting hardware, which can be ordered separately under Ident No. 33321100 (for 10 SEMITRANS 3)

This technical information specifies semiconductor devices but promises no characteristics. No warranty or guarantee expressed or implied is made regarding delivery, performance or suitability.